

HTP-10

Transformer Products



Hammond Power
Solutions Inc.

TABLE OF CONTENTS

INTRODUCTION



HPS, The Company.....	2
Transformer Terminology.....	4
Types of Transformers.....	11
General Transformer Construction Features.....	14
Transformer Basics.....	18
Selecting Transformers.....	20
Compliance with Engineering Standards.....	22
Transformer Test Standards.....	23
Quality Management Systems.....	25
HPS Standard Enclosures.....	26
HPS Warranty.....	28

SECTION 1

Industrial Control & General Purpose Enclosed Transformers



Control Transformer Quick Selection Charts.....	30
What is a Control Transformer?.....	31
Overcurrent Protection.....	32

HPS Imperator® Machine Tool Industrial Control Transformers

Features & Benefits.....	36
Selection Tables.....	38
Optional Accessories.....	45
Wiring Schematic Drawings.....	64

HPS Spartan® Industrial Open-Style Core & Coil Control Transformers

Features and Benefits.....	47
Selection Tables.....	48
Optional Accessories.....	53
Wiring Schematic Drawings.....	75

HPS Fusion™ General Purpose Enclosed Transformer

Features and Benefits.....	55
Selection Tables.....	56
Optional Accessories.....	61
Wiring Schematic Drawings.....	75

Q Series Enclosed Potted Control Transformer

Applications, Features and Specifications.....	62
Selection Tables.....	63
Wiring Schematic Drawings.....	277

SECTION 2

Buck-Boost Transformers



Why use Buck-Boost Transformers?.....	82
Buck-Boost Transformer Specifications.....	82
Steps for Selecting Buck-Boost Transformers.....	83
Single Phase Selection Tables.....	84
Three Phase Selection Tables.....	87
Single Phase Specification Tables.....	90
Three Phase Specification Tables.....	91
Single Phase Connection Diagrams.....	93
Three Phase Connection Diagrams.....	94
Buck-Boost Transformers - Questions & Answers.....	95



TABLE OF CONTENTS

SECTION 3

Three Phase Line Reactors and DV/DT Filters

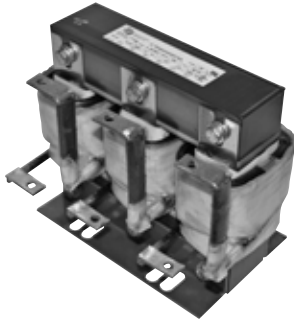

Why choose a Line Reactor?	100
Construction Features	103
Standard RM Line Reactor Specifications	105
RM Part Number Guide and Three Phase Selection Tables	106
RM Line Reactor Core & Coil Specification Tables	108
RM Line Reactor Enclosed Specification Tables	110
RM Line Reactor Application and Connection Diagrams	112
RM Line Reactor Termination Details	112
RM Line Reactor - Competitor Cross-Reference Table	113
RC DV/DT Filter Applications	114
RC DV/DT Filter Specifications	115
RC DV/DT Filter Part Number Guide and Selection Table	116
RM Line Reactor Open Style Reference Drawings	117
RC DV/DT Filter Open Style Reference Drawings	118

SECTION 4

Drive Isolation Transformers



Description & Applications	120
Selecting Drive Isolation Transformers.....	120
Standard Drive Isolation Transformers	
Aluminum and Copper Standard Specifications	121
Aluminum Selection Tables	122
Copper Selection Tables	126
Termination Details	131
HPS Tribune™ Energy Efficient Drive Isolation Transformers	
Aluminum and Copper Standard Specifications	132
Aluminum Selection Table	133
Copper Selection Tables	137
Termination Details	142
Enclosure Dimensional Drawings	260
Accessories	271
Electrical Schematics and Connections	276

SECTION 5

Motor Starting Autotransformers



Description and Applications	144
Copper Standard Specifications and Core & Coil Dimensional Drawings	145
Copper, Three Phase, 2-Coil Selection Tables	146
Copper, Three Phase, 3-Coil Selection Tables	147
Optional Thermostats	148

SECTION 6

Low Voltage Lighting Transformers



Single Phase Applications, Features and Specifications.....	150
Group A Selection Table	151
Group B Selection Table.....	151
Group C Selection Table.....	152
Enclosure Dimensional Drawings.....	262

TABLE OF CONTENTS

SECTION 7

Energy Efficient Distribution Transformers



Energy Efficiency Guidelines for the U.S.	154
Energy Efficiency Guidelines for Canada	155
NEMA Premium® Efficiency Transformer Program.....	156
Product Features and Applications.....	157
Energy Efficient Distribution Transformers Product Summary	157

HPS Sentinel® - Energy Efficient General Purpose

Single Phase, Aluminum and Copper Standard Specifications.....	160
Single Phase, Selection Tables	161
Three Phase, Aluminum and Copper Standard Specifications	165
Three Phase, Selection Tables.....	166

HPS SuperSentinel® Super Energy Efficient General Purpose

Single Phase, Aluminum and Copper Standard Specifications.....	175
Single Phase, Selection Tables	176
Three Phase, Aluminum and Copper Standard Specifications	180
Three Phase, Selection Tables.....	181

HPS Synergy® Energy Efficient K-Factor

K-Factor, Harmonics and Non-Linear Loads	189
Aluminum and Copper Standard Specifications	192
Three Phase, Selection Tables.....	193

HPS SuperSynergy® Super Energy Efficient K-Factor

Aluminum and Copper Standard Specifications	197
Three Phase, Selection Tables	198

HPS Centurion® Energy Efficient Harmonic Mitigating

600V Class Harmonic Mitigating Transformers	202
Three Phase, Aluminum and Copper Standard Specifications	204
Three Phase, Selection Tables	205

HPS SuperCenturion® Super Energy Efficient Harmonic Mitigating

Three Phase, Aluminum and Copper Standard Specifications	214
Three Phase, Selection Tables	215

Enclosure Dimensional Drawings.....	260
Accessories	271
Termination Details.....	275
Electrical Schematics and Connections	276

SECTION 8

Encapsulated Dry-Type Distribution Transformers



HPS Fortress Commercial Encapsulated Transformers

HPS Fortress Applications and Features	224
Single Phase, Standard Specifications	226
Single Phase, Selection Tables	227
Three Phase, Standard Specifications	230
Three Phase, Selection Tables	231

HPS TITAN Industrial Encapsulated Transformers

HPS TITAN Applications.....	233
HPS TITAN Features and Benefits.....	234
Single Phase Standard Specifications	235
Single Phase Selection Tables	236
Three Phase Standard Specifications	238
Three Phase Selection Tables.....	239

Enclosure Dimensional Drawings.....	260
Accessories	271
Electrical Schematics and Connections	276



TABLE OF CONTENTS

SECTION 9

Mini Power Plus



HPS PowerPlus Mini Power Center

Description and Applications	242
Features and Benefits	243
Single Phase Selection Tables	244
Enclosure Dimensional Drawings.....	268
Accessories	271
Electrical Schematics and Connections	289

SECTION 10

Autotransformers



Description and Applications	246
Three Phase Standard Specifications	247
Three Phase Selection Tables.....	248
Enclosure Dimensional Drawings.....	260
Accessories	271
Electrical Schematics and Connections	276

SECTION 10

General Purpose Medium Voltage Transformers



Medium Voltage Energy Efficient Guidelines	250
Energy Efficient Guidelines for the U.S.	250
Energy Efficient Guidelines for Canada	251
HPS Millennium Energy Efficient Medium Voltage Transformers	
Medium Voltage Applications and Specifications	252
Single Phase Aluminum Selection Tables	253
Single Phase Copper Selection Tables	254
Three Phase Aluminum Selection Tables	255
Three Phase Copper Selection Tables.....	257
Enclosure Dimensional Drawings.....	260
Accessories	271
Termination Details	275
Electrical Schematics and Connections	276

GENERAL INFORMATION

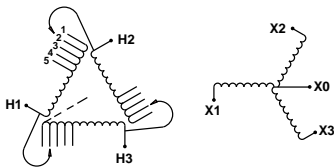

Detailed Enclosure Dimensional Drawings	260
Accessories - For General Purpose Transformers	271
Termination Details	275
Electrical Schematics and Connections	76
Alpha-Numeric Part Number Index	291
HPS Transformer Literature Request Form.....	316

TC4





INTRODUCTION

HPS, The Company	2
Transformer Terminology	4
Principles of a Transformer	10
Types of Transformers	11
General Transformer Construction Features	14
Transformer Basics	18
Selecting Transformers	20
Compliance With Engineering Standards	22
Transformer Test Standards	23
ISO 9001:2008.....	25
HPS Standard Enclosures	26
HPS Transformer Warranty	28

INTRODUCTION

THE COMPANY

Established in 1917, Hammond Power Solutions Inc. (HPS), formerly Hammond Manufacturing Ltd. - Transformer Group, continues as an industry leader in magnetic transformer design and development. With six plants located throughout North America, we have expanded our manufacturing and product base to offer you the broadest ranges of both standard and special reactors, control and dry-type transformers available anywhere.

Our engineering experience and capability has resulted in a computer database of over one million transformer designs. We offer the most cost effective, highest quality transformers necessary to satisfy your requirements.

The reactors, control transformers, dry-type distribution transformers, autotransformers, motor starting autotransformers and drive isolation transformers featured in this catalog are produced in six facilities that feature the most modern manufacturing processes. All products are available through your local **Authorized Hammond Distributor**.

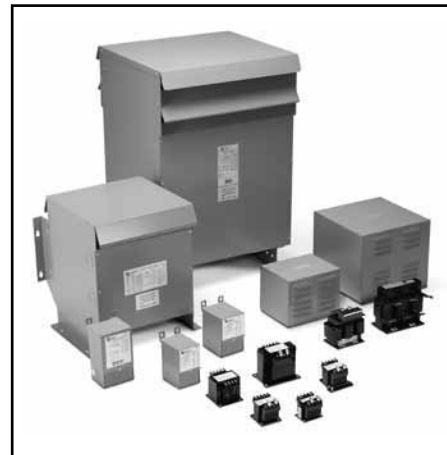

MANUFACTURING FACILITIES

Our objective is to supply the best value in dry-type transformers in North America. We are guided by our focus on quality, customer service and value to our customers, and the strength of our employees.

Hammond Power Solutions Inc. currently has six facilities:
Guelph, Ontario Walkerton, Ontario Granby, Quebec
Baraboo, Wisconsin Compton, California Monterrey, Mexico



WAREHOUSE FACILITIES

HPS has the most extensive inventory of any dry-type transformer manufacturer in North America. With ten regional warehouses strategically placed, HPS always has the product you need, where you need it and can deliver it when you need it.



CUSTOMER SERVICE

Our customer service personnel are available to answer your questions immediately. They are technically trained and are able to answer most questions on the phone. Stock checks, expediting, quotations or technical information are always readily available. Our commitment to customer service means you will be an informed, relaxed and satisfied customer as quickly as possible. Call our Inside Sales team and let us serve you.



INTRODUCTION

APPLICATIONS

Offering standard three phase ratings up to 1000 kVA and specials to 34 MVA, we feature state of the art technology and manufacturing processes. With continued development in technology of materials, designs and manufacturing methods, the use of dry-type transformers is growing rapidly throughout North America.

HPS transformers are suitable for any commercial, industrial, manufacturing or production process application and can be engineered for any environmental condition.

In addition to conventional indoor applications, our dry units can be built for outdoor locations, where airborne contaminants pose a risk to electrical equipment.

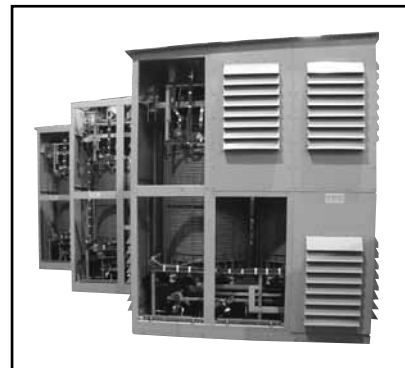

DESIGN CAPABILITIES

Our history and experience in transformer magnetic design is the very best in the industry. Our extensive testing program, including all qualification tests and short circuit testing, plus an exemplary field service record, ensures that our products not only meet all the standards necessary, but more importantly, fulfill your expectations and requirements.

All HPS designs are cost effective and the transformers are built with modern manufacturing techniques. We particularly emphasize our Value Added Engineering whereby our design staff will interface with your team to produce the optimum transformer. Our fully computerized design and CAD facilities permits quick and effective communication when time is vital.



A RELIABLE SOURCE

For over 90 years, HPS has continued to grow from a small family business to the industry leader in dry-type transformer technology. Our customers have come to rely on our products and services and continue to depend on us for support at the most critical stages of their need. Our stability and integrity as a supplier are paramount particularly in an industry where demands must be resolved quickly and effectively.



TECHNICAL SUPPORT

The HPS experienced technical team is available to help you with your application or design questions. Call our regional offices for assistance.

QUALITY ASSURANCE

HPS has been regarded for its quality since its very inception. With our commitment to 'Excellence' and 'Continuous Improvement', we build value and reliability into every HPS product. We feel that no other transformer company can offer comparable flexibility for service and quality in a full range of products. All our units are designed to meet ANSI, CSA, UL, IEC, RoHS and NEMA standards.

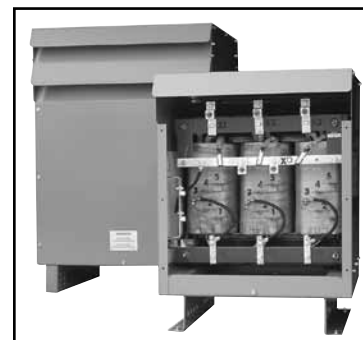

TRANSFORMER TERMINOLOGY

Air Cooled

A transformer which uses “air” as the cooling medium. This term is abbreviated with the ANSI designation AA, indicating open, natural draft ventilated construction.

Ambient Noise Level

The noise level of the surrounding area, measured in decibels (dB).

Ambient Temperature

The inherent or existing temperature of the atmosphere surrounding a transformer into which its heat is dissipated.

Ampere

Is the unit of measurement for electric current flow.

ANSI

American National Standards Institute Inc. - one of the recognized organizations which specifies the standards for transformers.

Autotransformer

A transformer which has only one winding per phase, part of which is common to both the primary and secondary circuits.

Banked

Two or more single phase transformers connected together to supply a three phase load.

BIL

Basic impulse level is a means to express the ability of the insulation system to withstand high voltage surges.

Buck Boost Transformer

Two-winding, single phase transformer with low voltage secondary windings which can be connected as an autotransformer. Used to raise or lower single and three phase line voltages by 10 - 20%.

Cast Coil Transformer

Transformer with coils solidly cast in epoxy resin under

vacuum in a mold. Also called cast resin or epoxy cast coil transformers.

Center Tap

A reduced capacity tap at the midpoint in a winding.

Coil

Turns of electrical grade wire or strip conductor material wound on a form, referred to as a winding.

Coil Hot-Spot Temperature

The absolute maximum temperature present in the transformer. This number is equal to the sum of the ambient temperature, temperature rise and a variable. $T \text{ Hot Spot} = T \text{ ambient} + T \text{ rise} + (10-20)^{\circ}\text{C}$.

Common Mode

Electrical noise or voltage disturbance that occurs between all of the line leads and the common ground, or between the ground plane and either line or the neutral.

Compensated Transformer

A transformer with a turns ratio which provides a higher than rated voltage at no load and rated voltage at rated load. These transformers CANNOT be used for reverse feed.

Continuous Rating

The constant load which a transformer can carry its rated primary voltage and frequency, without exceeding its specified temperature rise.

Control Transformer

A transformer which is designed to supply good voltage regulation characteristics when low power factor or high inrush current is drawn. Sometimes referred to as an Industrial Control Transformer.

Core

Electrical grade steel laminations which carry the magnetic flux.

Core Loss

Losses in watts caused by magnetization of the core and its resistance to magnetic flux when excited or energized at rated voltage and frequency. Also referred to as excitation loss or no-load loss.

Current Transformer

Transformer generally used in control or instrumentation circuits for measuring current.

Delta Connection (Δ)

The delta connection is a standard three phase connection with the ends of each phase winding connected in series to form a closed loop with each phase 120 degrees from the other.

Delta Wye (ΔY)

Delta wye is a term indicating the primary connected in delta and the secondary in wye when pertaining to a three phase transformer bank or three phase transformer.

Dielectric Tests

These tests consist of the application of a voltage higher than the rated voltage for a specified time, for the purpose of determining the adequacy against breakdowns of insulating materials and spacings under normal conditions.

Dry-Type Transformer

A dry-type transformer is one in which the transformer core and coils are not immersed in liquid.

Dual Winding

A winding consisting of two separate parts which can be connected in series or parallel. Also referred to as dual voltage or series-multiple winding.

Efficiency

The percentage of power transferred from the input of equipment to the output of equipment in Watts. (power out/power in x 100)

Electrostatic Shield

Copper or other conducting material placed between the primary and secondary winding and grounded to reduce electrical interference and to provide additional protection.

Exciting Current (No-Load Current)

Current which flows in any winding used to excite the transformer when all other windings are open-circuited. It is usually expressed in percent of the rated current of a winding in which it is measured.

Encapsulated

Transformer with its coils either encased or cast in an epoxy resin or other encapsulating materials.

FCAN

Full Capacity Above Normal. This designates that a transformer will deliver its rated kVA when connected to a voltage source which is higher than the rated voltage.

FCBN

Full Capacity Below Normal. Same as FCAN except that the taps are below rated voltage.

Fan Cooled

A transformer cooled mechanically to maintain its rated temperature rise, typically using auxiliary fans to accelerate heat dissipation.

Flexible Connection

A non-rigid connection used to reduce transmission of noise and vibration.

Flux Density

The magnetic field strength in the core, typically measured in Telsa or Gauss.

Frequency

On AC circuits, designates the number of times the polarity alternates from positive to negative and back again, such as 60 cycles per second. Measured in Hertz.

INTRODUCTION

TERMINOLOGY CONTINUED . . .

Full Capacity Tap

A full capacity tap is one through which the transformer can deliver its rated kVA output without exceeding the specified temperature rise.

Grounding Transformer

A special three phase autotransformer for establishing a neutral on a 3-wire delta secondary. Also referred to as a Zig-Zag transformer.

Grounds or Grounding

Connecting one side of a circuit to the earth through low resistance or low impedance paths.

Harmonic

A Harmonic is a sinusoidal component of a periodic wave having a frequency that is a multiple of the fundamental frequency. For example, a component whose frequency is twice the fundamental frequency is referred to as the second harmonic, (120 Hz is the 2nd harmonic of 60 Hz).

Hertz (Hz)

A term for AC frequency in cycles per second.

High Voltage and Low Voltage Windings

These terms are used to distinguish the winding having the greater voltage rating from that having the lesser in two winding transformers.

Hi Pot

High potential dielectric test impressed on the windings to check insulation materials and clearances.

Impedance

The apparent resistance in a circuit to the flow of an alternating current analogous to the actual resistance to a direct current.

Impulse Test

Dielectric test which determines BIL capability by applying high frequency, steep wave-front voltage between windings and ground.

Induced Potential Test

A standard dielectric test which verifies the integrity of insulating materials and electrical clearances between turns and layers of a transformer winding.

Inductance

A property which opposes a change in current flow.

Inrush Current

High transient current, caused by residual flux in the core, which may be drawn when a transformer is energized.

Insulating Materials

Those materials used to electrically insulate the transformer's windings; turn-to-turn or layer-to-layer, and other assemblies in the transformer such as the core and busswork.

Isolation Transformer

A transformer which insulates the primary circuit from the secondary circuit. Also referred to as a two-winding or insulating transformer.

KVA

Kilovolt ampere rating designates the output which a transformer can deliver for a specified time at rated secondary voltage and rated frequency without exceeding the specified temperature rise. (1 kVA = 1000 VA, or 1000 volt amperes)

Knockouts

Easily removable circle of metal in an enclosure which eliminates the need for punching holes for conduit.

Lamination

Thin sheets of special steel used to make the core of a transformer.

Line Reactor

A device whose primary purpose is to introduce a specific amount of inductive reactance into a circuit, usually to reduce or control current.



Load

The load of a transformer is the power in kVA or volt amperes supplied by the transformer.

Load Losses

Losses in a transformer which are incident to load carrying. Load losses include I^2R loss in the windings due to load current, stray loss due to stray fluxes in the windings, core clamps, etc., and to circulating currents (if any), in parallel windings.

Mini Power Center

A pre-wired power center that combines primary breaker, secondary power panel, and a dry-type shielded transformer.

Mid-tap

A reduced capacity tap midway in a winding. Also referred to as a 'Center tap'. Usually in the secondary winding.

Moisture Resistance

Materials or equipment constructed or treated so that it will not be harmed readily by exposure to a moist atmosphere.

NEC

National Electric Code

NEMA

National Electrical Manufacturers Association.

No-Load Losses (Excitation Losses)

Loss in a transformer which is excited at rated voltage and frequency, but without a load connected to the secondary. No-load losses include core loss, dielectric loss, and copper loss in the winding due to exciting current.

Overload

When a transformer is overloaded, excessive heat develops and the insulation system begins to breakdown. Life expectancy of the transformer is

decreased due to heat exceeding the rating of the insulation system.

Parallel Operation

Single and three phase transformers may be operated in parallel by connecting similarly marked terminals, provided their ratios, voltages, resistances, reactances and ground connections are designed to permit parallel operation. Current and voltage angular displacements are also required to be the same in the case of three phase transformers.

Phase

Type of AC electrical circuit, usually single phase 2 wire or 3 wire, or three phase, 3 or 4 wire.

Polarity

Designates the instantaneous direction of voltages in the primary compared to the secondary.

Potential (Voltage) Transformer

A transformer generally used in instrumentation circuits for measuring or controlling voltage.

Power Factor

The relation of watts to volt amps in a circuit.

Primary Taps

Taps added to the primary winding. (see Taps)

Primary Voltage Rating

Designates the input circuit voltage for which the primary winding is designed.

Primary Winding

The primary winding is the winding on the energy input (supply) side.

Rating

The design characteristics, such as primary and secondary voltage, kVA capacity, temperature rise, frequency, etc.

INTRODUCTION

TERMINOLOGY CONTINUED . . .

Ratio (Voltage)

A reference to either the primary to secondary winding turns ratio or to the voltage ratio of the transformer.

Ratio Test

A standard test of transformers to determine the ratio of the primary to secondary voltage.

Reactance

The impedance component due to inductance and/or capacitance.

Reactor

A single winding device with an air or iron core which produces a specific amount of inductive reactance into a circuit, usually to reduce or control current.

Rectifier Transformer

A transformer designed to supply AC input to a rectifier to obtain the desired DC output and have the ability to withstand the heating effects caused by rectifier commutation or ripple.

RCBN - Reduced Capacity Below Normal

Taps which carry full-rated winding current only, thus reducing available power because of lower output voltage.

Regulation

Usually expressed as the percent change output voltage when the load goes from full load to no load at a given power factor.

SCR

A silicon-controlled rectifier.

Saturation

Saturation is a natural condition in which an increase in current results in a decrease in inductance.

Scott Connection

Connection for polyphase using two special single phase transformers. Usually used to change from two phase to three phase or three phase to two phase.

Secondary Voltage Rating

Designates the no-load circuit voltage for which the secondary winding (winding on the output side) is designed.

Secondary Winding

The transformer winding connected to the load or output side.

Series/Multiple

A winding consisting of two or more sections which can be connected for series operation or multiple (parallel) operation. Also referred to as dual voltage or series-parallel.

Short Circuit

A short circuit condition occurs when an abnormal connection or relatively low impedance, whether made accidentally or intentionally, occurs between two points of different potential in a circuit.

Solid State Device

One which contains components that do not depend on electronic conduction in a vacuum or gas. The electrical function is performed by semiconductors or the use of otherwise completely static components such as resistors or capacitors.

Step-Down Transformer

One in which the high voltage winding (primary) is connected to the input or power source and the low voltage winding (secondary) to the output or load.

Step-Up Transformer

A transformer in which the low voltage winding (secondary) is connected to the input or power source and the high voltage winding (primary) is connected to the output or load.

Tap

A tap is a connection brought out of a winding at some point between its extremities, usually to permit changing the voltage or current ratio.



T-Connection

A Scott connected three phase transformer utilizing two primary and two secondary coils called the main and the teaser.

Temperature Class

The maximum temperature that the insulation can continuously withstand. Class of insulation system in a transformer, i.e.

Class 105°C

Class 150°C

Class 180°C

Class 220°C

Temperature Rise

The increase over ambient temperature of the winding due to energizing and loading the transformer.

Total Losses

The transformer electrical losses which include no-load losses (core losses) and load losses (winding losses).

Transformer

A static electrical device which by electromagnetic induction transforms energy at one voltage and current to another voltage and current at the same frequency.

Transient

A temporary or brief change in a given parameter. This is typically associated with input voltage or output load parameters.

Transformer Tests

Normal, routine production tests include: (1) core loss; (2) load loss - winding or copper loss; (3) impedance; (4) hi-pot - high voltage between windings and ground; (5) induced - double induced two times voltage. Optional special tests include: (a) heat run - temperature testing; (b) noise tests - sound level measurement; (c) impulse tests - BIL tests: (d) partial discharge.

Transverse Mode

Electrical noise or voltage disturbance that occurs between phase and neutral (between lines), or from spurious signals across the metallic hot line and the neutral conductor.

UL

Underwriters Laboratories

VPI Impregnation

A vacuum and pressure impregnation process using a resin which is then oven cured to completely seal and protect the surface of a transformer and provides a strong mechanical bond. This process is standard on all HPS transformer products.

Voltage Regulation

The change in secondary voltage which occurs when the load is reduced from rated value to zero, with the value of all other quantities remaining unchanged. Regulation may be expressed in percent (per unit) on the basis of rated secondary voltage at full load.

Volt-Amperes (VA)

The current flowing in a circuit multiplied by the voltage of the circuit. An expression of the output rating of a transformer.

Wye Connection

A standard 3-wire transformer connection with similar ends of the single phase coils connected. This common point forms the electrical neutral point and may be grounded.

Zig Zag Connection

Special transformer connection commonly used in grounded transformers. See also grounding transformers.

WHAT IS A TRANSFORMER?

A transformer is an electrical device which converts alternating current from one voltage to another. It can be designed to “step-up” or “step-down” voltages and works on the magnetic induction principle. A transformer has no moving parts and is a completely static solid state device which insures, under normal operating conditions, a long and trouble-free life. A transformer consists of two or more coils of insulated wire wound on a laminated steel core. When voltage is introduced into one coil (called the primary), it magnetizes the iron core. As a result, a voltage is induced into the secondary, or output coil. The change of voltage (voltage ratio) between the primary and secondary depends on the turns ratio of the two coils.

WHAT DOES A TRANSFORMER DO?

Principle of Operation

A transformer operates on the principle of magnetic induction. Each transformer consists of two or more coils of insulated conductor (wire) wound on a laminated steel core. When a voltage is supplied to the PRIMARY (input) coil, it magnetizes the steel core, which in turn induces a voltage on the SECONDARY (output) coil. The voltage induced from the primary to the secondary coils is directly proportional to the turns ratio between the two coils. **(FIG 1)**

For example, if a transformer’s input, or primary leg has twice as many turns of wire as the secondary, then the ratio would be 2:1. Therefore, if you applied 480 volts to the primary, 240 volts would be induced in the secondary. This is an example of a two winding “step-down” transformer. **(FIG 2)**. If the voltage is to be “stepped-up” or increased, the same transformer could be turned around and connected so that the input side would have the 240 volts and the output would be 480 volts. **(FIG 3)**

Standard transformers rated at 3 kVA and larger can be used for either step-up or step-down service. Transformers rated 2 kVA and below have compensated windings and should not be used in reverse feed applications. (Note: some system design considerations apply.)

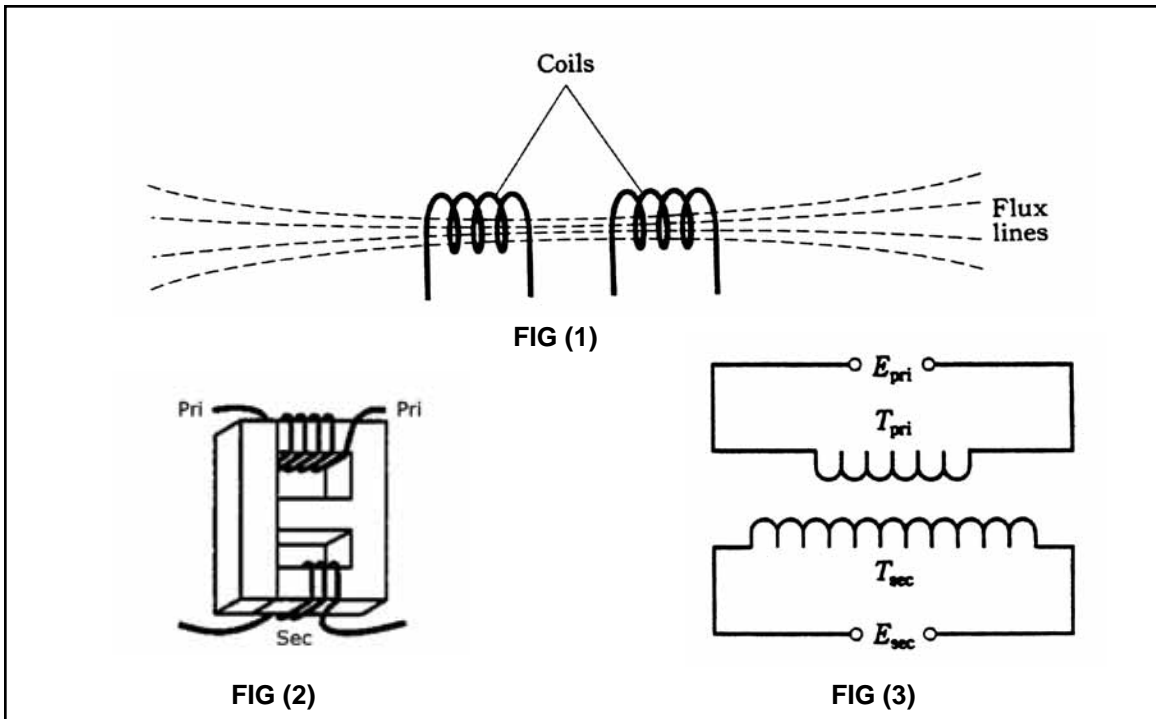

TYPES OF TRANSFORMERS

Dry-type transformers are manufactured in a variety of ways to meet the requirements of different applications. The following is a list of transformer types found in this catalog with a brief explanation.

Industrial Control and General Purpose Enclosed Transformers - (see Section 1)

A control transformer is an isolation transformer designed to provide a high degree of secondary voltage stability (regulation) during a brief period of overload condition (also referred to as “Inrush Current”). Control transformers are usually rated for 600 volts or less.

Buck-Boost Transformers - (see Section 2)

Buck-Boost transformers are control transformers with low voltage secondary windings. By field connecting the primary and secondary windings in an autotransformer configuration, they offer an economical solution to the adjustment of line voltages that are slightly above or below normal.

Buck-Boost transformers can be used to adjust **stable voltages only**. Fluctuating line voltages should be regulated with a Hammond Voltage Conditioner.

Reactors - (see Section 3)

Air Core:

They are used primarily as current or voltage limiting devices, particularly where large currents can enter a system that uses small amounts of power. An example is the telephone system which uses very small voltages where the current in a fault condition needs to be kept to a minimum.

Iron Core:

An iron core reactor provides the same current or voltage control on a system as its air core counterpart. Iron core units tend to be used on smaller applications where the variables need greater or more sensitive control.

Drive Isolation Transformers - (see Section 4)

Drive isolation transformers are designed to supply power to AC and DC variable speed drives. The harmonics created by SCR type drives requires careful designing to match the rated hp of each drive system. The duty cycle included is approximately one start every 2 hours. The windings are designed for an overcurrent of 150% for 60 seconds, or 200% for 30 seconds.

Motor Starting Autotransformers - (see Section 5)

Motors have a large inrush current component that requires a special design. Motor starting autotransformers are designed to withstand an inrush of upwards of 25 times normal current. Typically, they are tapped on larger sizes to soft-start the motor until it is up to full RPM.

Types of Transformers continued . . .

Low Voltage General Purpose Transformers - (see Section 6)

HPS low voltage general purpose transformers provide a safe, long lasting, highly reliable power source. They are designed for general lighting and other low voltage applications. They are UL listed and CSA certified.

Energy Efficient Transformers - (see Section 7)

There is a growing movement in the electrical industry towards energy efficient products in all sectors including dry-type transformers. In addition to the benefits to the environment, energy efficient transformers also can realize substantial savings in operating costs thereby having a direct impact on the initial investment evaluated over a period of time.

The standards covering 600 volt class energy efficiency in dry-type transformers in North America are outlined in DOE 10 CFR Part 431, "Energy Conservation Program for Commercial Equipment: Distribution Transformers Energy Conservation Standards; Final Rule". These specifications have carefully considered the total owning cost unique for industrial or commercial installations where the load factor is an integral part of the efficiency rating.

Energy Efficient General Purpose Transformers

The HPS Sentinel® energy efficient general purpose transformers are designed for linear loads and are most frequently used for applications such as commercial buildings which will supply a variety of general loads.

Energy Efficient K-Factor Transformers

The HPS Synergy® energy efficient k-factor transformers are designed to tolerate heating due to harmonics associated with non-linear loads. Harmonics can indicate their presence in a number of ways: overheating, device malfunctions, telephone interference, equipment vibration and breakers tripping.

Energy Efficient Harmonic Mitigating Transformers

The HPS Centurion® energy efficient, harmonic mitigating transformer with zero sequence flux cancellation technology is specifically designed to treat the harmonics generated by computer equipment and other non-linear, power electronic loads. Combining zero sequence flux cancellation with phase shifting treats 3rd, 5th, 7th, 9th, 15th, 17th and 19th harmonics within its secondary windings. Typical applications of severe non-linear loading conditions include data centers, internet-service providers, telecom sites, call centers, broadcast centers, etc.

Types of Transformers continued . . .

Encapsulated (Potted) Transformers - (see Section 8)

HPS offers two complete lines of encapsulated transformers to meet both a commercial and industrial environment. These units are encapsulated and completely enclosed.

Encapsulated Transformers for Commercial Use

The Fortress™ is designed to provide the ideal solution for commercial applications. All units are encapsulated with electrical grade silica sand and resin compounds, which completely enclose the core and coil to seal out moisture, airborne contaminants and eliminates corrosion and deterioration.

Encapsulated Transformers for Harsh Environments and Hazardous Locations

The HPS Titan® design is especially suited for installations in harsh environments and hazardous locations which may contain dangerous gasses, liquids, dust, lint, moisture and where corrosive contaminants are present. Typical applications include: institutional, commercial, industrial, petrochemical, pulp and paper; food processing, mines, marine and shipboard installations. They are designed to meet both UL Standard 1604 entitled “*Electrical Equipment for use in Class I and Class II, Division 2 and Class III Hazardous (Classified) Locations*” and ABS Type Approval for “*Marine Duty Service and Offshore Applications - Electrical Distribution and Propulsion*”.

Mini Power Centers - (see Section 9)

HPS power centers are conveniently pre-wired to save you time, money, and space. They're designed ideally for industrial locations, temporary power at construction sites, commercial buildings, test equipment, plant assembly lines, etc.

Autotransformers - (see Section 10)

Autotransformers are similar to Buck-Boost transformers in that they are also an economical means of adjusting output voltage. Autotransformers are designed to adjust the supply voltage when isolation from the line is not necessary and where local electrical codes permit. Units are designed in either a step-up or step-down application and meet motor inrush currents.

Energy Efficient Medium Voltage Distribution Transformers - (see Section 11)

As of January 1st, 2010, all dry-type medium voltage distribution transformers manufactured or imported into North America must comply with the new DOE 10 CFR Part 431/NRCan standards. These standards were put in place to reduce additional energy consumption, as well as reduce greenhouse gases.

HPS Millennium™ transformers are really 5kV class dry-type energy efficient distribution transformers. They are designed primarily for use in stepping down medium voltage power (i.e. 4160V or 2400V primary) to a lower voltage for commercial, institutional or industrial applications.



INTRODUCTION

CONSTRUCTION FEATURES

Standard transformers are designed and constructed to meet or exceed the requirements for general applications. These transformers are provided either ventilated or totally enclosed. To meet special applications or custom requirements, modifications are available as either factory installed options or field installed accessories.

Please note that construction details for our Control Transformers and Three Phase Line Reactors are in sections 1 and 3 respectively.

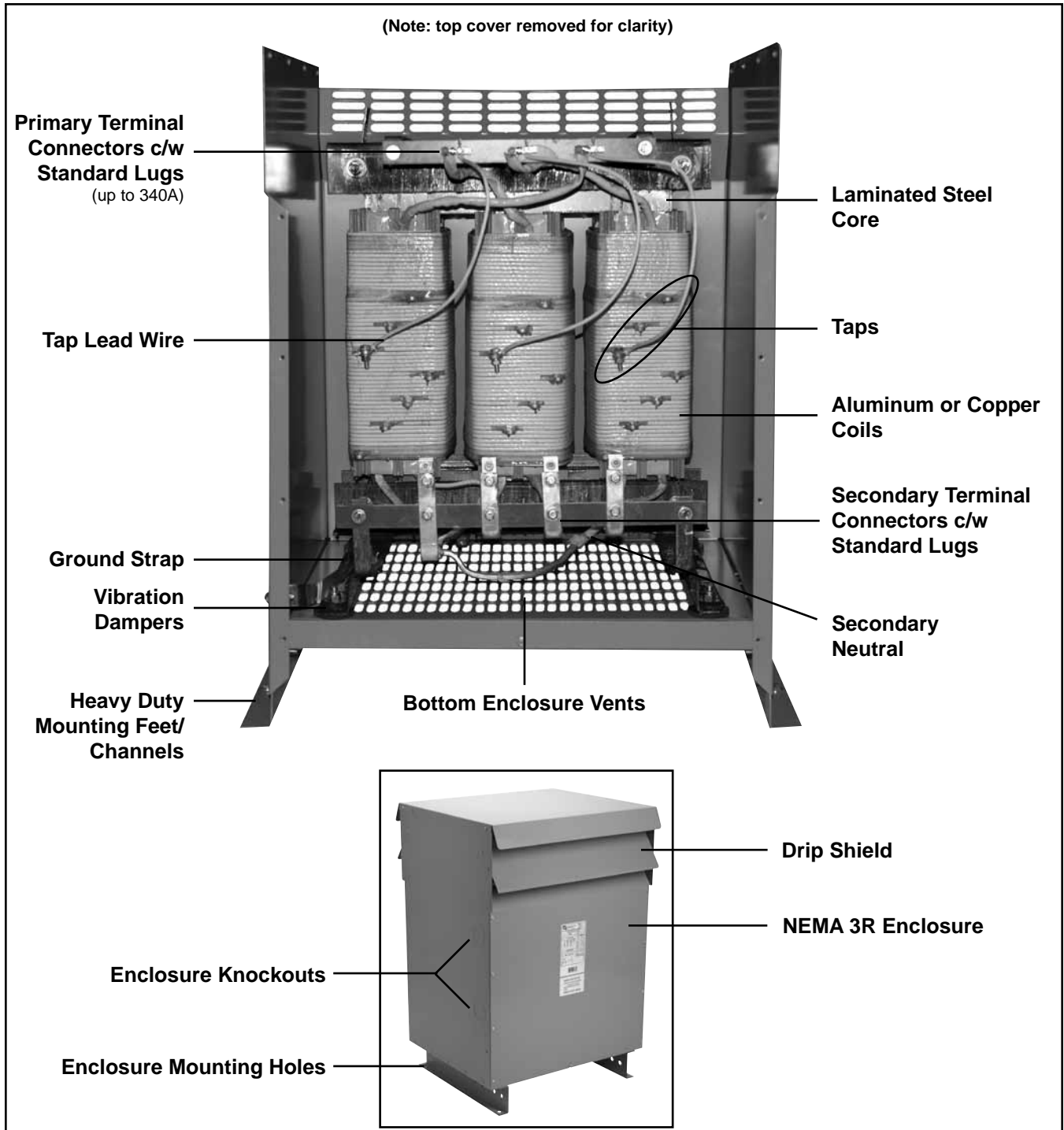

CONSTRUCTION FEATURES continued . . .

Core Construction

HPS cores are manufactured from the highest quality non-aging, cold rolled, silicon steel laminations. Cores are precision cut to close tolerances to eliminate burrs and improve performance. Most feature fully interleaved stepped core construction for optimum energy efficiency.

Cores are carefully assembled and rigidly clamped and then either bolted or welded to minimize gaps and assure low losses and quiet operation.

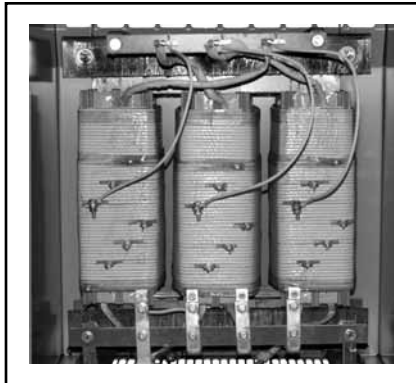

Coil Construction

Coils are available in either aluminium or copper construction. Coils are precision wound with continuous copper or aluminum conductors and are electrically balanced to minimize axial short-circuit forces.

The use of duct stick permits the flow of air thus providing excellent cooling in addition to providing superior axial mechanical strength.

Terminations

HPS transformers are provided (where applicable) with both high and low terminal connectors suitable for both copper and aluminum cables. These connectors allow for easy field installation without the need to purchase connectors separately, saving the installer both time and money. For details on types and sizes of connectors provided, please refer to the features tables located within each product section.



Insulation System

The insulation rating is the maximum allowable winding (hot spot) temperature of a transformer operating at an ambient temperature of 40°C. Insulation systems are classified by the temperature rating. The following table summarizes the different insulation systems available.

Insulation Rating	Insulation Class	Average Winding Temperature Rise	Hot Spot Temperature Rise	Maximum Winding Temperature
Class 105	A	55°C	65°C	105°C
Class 150 or 130	B	80°C	110°C	150°C
Class 180	F	115°C	145°C	180°C
Class 200	N	130°C	160°C	200°C
Class 220	H	150°C	180°C	220°C

NOTE: The maximum acceptable temperature rise based on an average ambient of 30°C during any 24 hour period and a maximum ambient of 40°C at any time.

INTRODUCTION

CONSTRUCTION FEATURES continued . . .

VACUUM PRESSURE IMPREGNATION (VPI)

The following briefly describes our process.

Polyester Resin Impregnation

For most applications, regardless of voltage class, HPS' polyester resin impregnation system is preferred. The polyester resin exhibits a much higher dielectric strength and bonding properties than any varnish previously used, or other encapsulations including oil modified epoxies. This polyester resin exhibits these characteristics:

- Low moisture absorption (Non-Hydroscopic)
- High dielectric strength
- High bond strength
- Excellent mechanical properties
- Stability at high temperatures
- Excellent thermal shock properties
- Longevity of life at maximum transformer temperatures
- UL approved for 220°C insulation systems for any voltage class
- Fungus-resistant reactive components makes it environmentally superior.

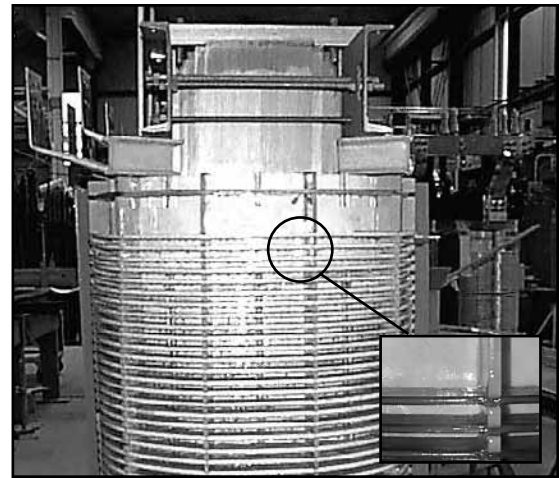

For long-term life expectancy, it is critical that transformers maintain the integrity of the dielectric properties of the insulation materials.

At HPS, transformer coils are impregnated with a complete vacuum-pressure impregnating cycle:

- Coils are placed in a sealed tank and a vacuum is drawn.
- The resin is then introduced into the chamber and the assembly is completely immersed.

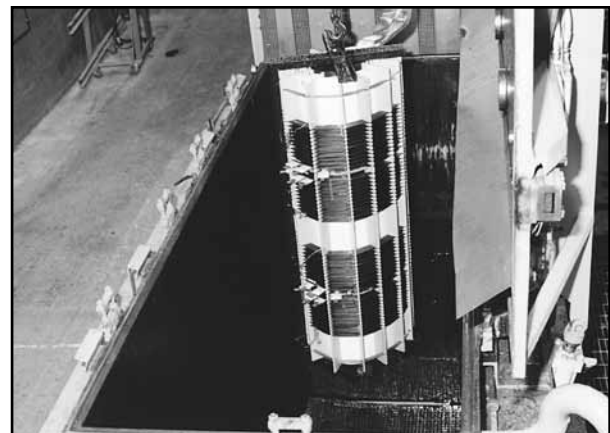

INTRODUCTION

CONSTRUCTION FEATURES continued . . .

Vacuum Pressure Impregnation continued . . .

- The tank is then pressurized to force the impregnation material to thoroughly penetrate the windings.
- The coils or assembly are then removed from the chamber and oven cured.
- These steps are then repeated.



Vacuum Pressure Chamber

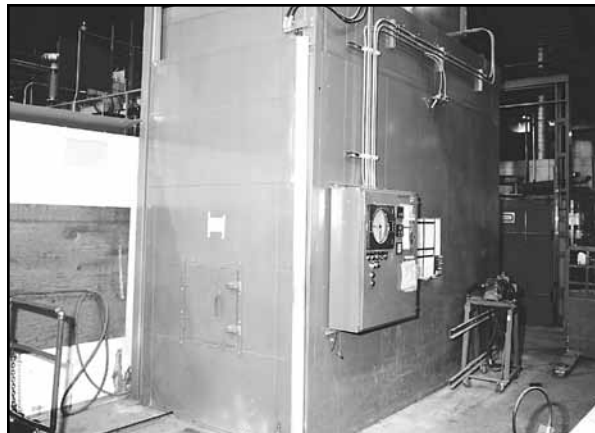

Baking Oven

The result is transformers whose coils exhibit virtually corona-free performance, a superior resistance to environmental conditions and a new standard of reliability even for the worst industrial, utility or commercial applications.

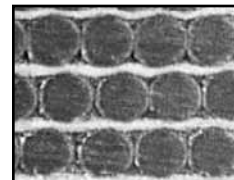

TRANSFORMER BASICS

Banking of Transformers

Two or three single phase transformers can be connected to make a three phase bank. The primary windings of the single phase transformers can be connected in delta or wye. The secondary windings can also be connected in either a delta or wye configuration. The equivalent capacity of the bank will be equal to three times the nameplate rating of each single phase transformer. Usually this type of installation is more expensive than using a single three phase transformer.

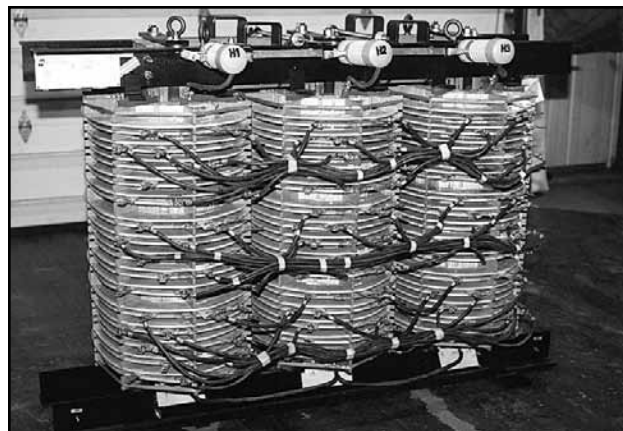

Primary Voltage Taps

In some cases, the actual supply voltage to the primary of the transformer is either slightly higher or lower than the nameplate rating. Taps are provided on most transformers on the primary winding to correct this condition and maintain full rated output voltage and capacity. Standard taps are usually in 2 1/2% or 5% increments. Example: The transformer has a 480V primary rating and the incoming voltage is at 504V. The primary connection should be made at the +5% tap in order to maintain the nominal secondary voltage.

Transformer Operation at 50 Hz

Transformers rated at 60Hz should not be used on a 50Hz supply due to higher losses and core saturation and the resultant higher temperature rise. Transformers rated for 50Hz, however, can be operated on a 60Hz supply.

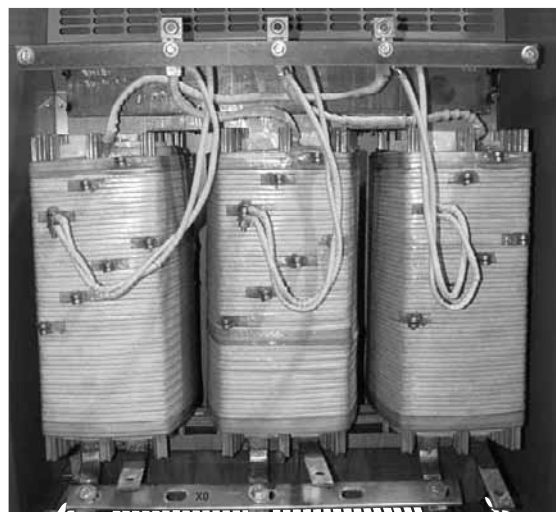

Transformer Basics continued . . .



Balance Loading on Single and Three Phase Transformers

A single phase transformer with 120/240V secondary has two separate 120V secondary windings and is usually connected into a 3 wire system. Care must be exercised in distributing the load on the two 120V windings evenly, so each winding is carrying about half of the total load.

Similarly for a three phase transformer, each phase should be considered as a single phase transformer. When distributing single phase loads between the three phases, each of the three windings should be evenly loaded.

Reverse Connection

In general, distribution transformers can be reverse connected without derating the nameplate kVA capacity. However, some precautions need to be taken for reverse connection of some smaller transformers. On HPS transformers under 6 kVA three phase and 3 kVA single phase, there is a “turns ratio compensation” on the low voltage winding. When the input voltage, equal to the nameplate rated voltage, is connected to the low voltage winding, the output voltage will be slightly lower than the nameplate rating.

When a three phase transformer is reverse connected thus resulting in a Wye-Delta configuration, the neutral terminal must be isolated.

Further, the reverse connected transformer may draw a higher inrush current during energization. Hence the sizing of the line fusing or circuit breaker may be affected.

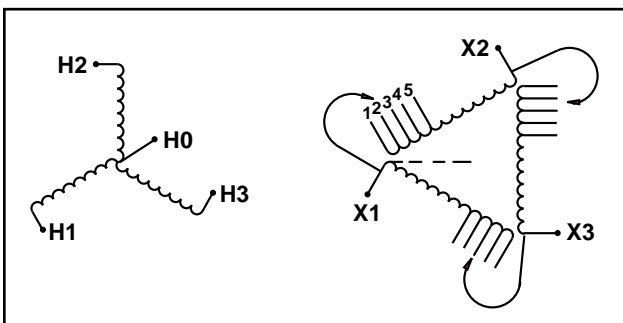

Sound Level

Sound needs to be considered when transformers are located in close proximity to occupied areas. All energized transformers emanate sound due to the alternating flux in the core. This normal sound emitted by the transformer can be a source of annoyance unless it is kept below acceptable levels. There are ways of minimizing sound emission as discussed in the HPS “Field Service Guide” (TIB04).

HPS transformers are built to meet the latest ANSI, CSA and UL standards. These standards use NEMA-ST20 (see below table for outline).

Equivalent Two Winding kVA	Self Cooled Ventilated Voltage Line to Line		Self Cooled Non-Ventilated dB-A
	1.2kV dB-A	> 1.2kV dB-A	
0-9	40	45	45
10-50	45	50	50
51-150	50	55	55
151-300	55	58	57
301-500	60	60	59
501-700	62	62	61
701-1000	64	64	63

HPS also offers “Low Sound” options to most of it distribution style transformers. Please contact your HPS sales representative for details.

SELECTING TRANSFORMERS

SINGLE PHASE

A single phase transformer is designed to transform single phase or three phase input (source) voltage to the single phase output (load) voltage required by your equipment. To select the correct single phase transformer you must first determine:

- 1) The equipment being installed operates on a **single phase** supply (see your equipment nameplate or installation manual).
- 2) The **Primary Voltage** of the transformer. This is the same as the line input (or source) voltage, typically 480 or 600 volts AC.
- 3) The **Secondary Voltage** of the transformer. The equipment being installed will have a specified supply voltage (see equipment nameplate or installation manual). The transformer you select must have a secondary voltage equal to the required supply voltage of the equipment, typically 120/240 VAC.
- 4) The **Frequency** in Hertz (cycles-per-second) of the input (source) voltage must be the same as the operating frequency of the equipment being supplied. The transformer selected must operate at the same frequency. Typical operating frequency is 60 Hz.
- 5) The **Total VA** of the load is determined by the product of the voltage supplied across the load and the current passing through it. This is normally expressed in VA (Volt-Amperes) or kVA (kilo Volt-Amperes) on the equipment nameplate. The total load is often a combination of various loads (i.e. lights, heaters, motors). You must calculate these individual loads and add them together to obtain the total load of the transformer. The transformer you select must have a kVA rating equal to or greater than the load on the transformer.

How to use the full load chart to find kVA:

- A) Determine the secondary voltage of your transformer.
- B) Sum up the total amperes required by the load.
- C) From the full load current table below, select a transformer under the corresponding secondary voltage, with a standard kVA capacity and amperage equal to or higher than the sum required by the load.

Calculating kVA: To calculate kVA when volts and amperes are known:

$$\text{kVA} = \frac{\text{Volts X Amps (load)}}{1000}$$

Full Load Current Table
Single Phase Transformer

kVA	Current in Amperes						
	120V	240V	416V	480V	600V	2400V	4160V
0.25	2.08	1.04	0.60	0.52	0.41	-	-
0.50	4.16	2.08	1.20	1.04	0.83	-	-
0.75	6.25	3.13	1.80	1.56	1.25	-	-
1.0	8.33	4.17	2.40	2.08	1.67	-	-
1.5	12.5	6.25	3.60	3.13	2.50	-	-
2.0	16.7	8.33	4.81	4.17	3.33	-	-
3.0	25.0	12.5	7.21	6.25	5.00	1.25	0.72
5.0	41.6	20.8	12.0	10.4	8.33	2.08	1.20
7.5	62.5	31.2	18.0	15.6	12.5	3.12	1.80
10	83.3	41.6	24.0	20.8	16.6	4.16	2.40
15	125	62.5	36.0	31.2	25.0	6.25	3.60
25	208	104	60.0	52.0	41.6	10.4	6.00
37.5	312	156	90.1	78.1	62.5	15.6	9.01
50	416	208	120	104	83.3	20.8	12.0
75	625	312	180	156	125	31.2	18.0
100	833	416	240	208	166	41.6	24.0
150	1250	625	360	312	250	62.5	36.0
167	1391	695	401	347	278	69.5	40.1
250	2083	1041	600	520	416	104	60.0
333	2775	1387	800	693	555	138	80.0

Single Phase AC Motor Full Load Running Currents in Amperes and Recommended Transformer Ratings

Horsepower	Full Load Current (Amps)			Minimum Transformer KVA
	110-120V	208V	220-240V*	
.50 HP	9.8	5.4	4.9	1.5
.75 HP	13.8	7.6	6.9	2.0
1 HP	16.0	8.8	8.0	3.0
1.5 HP	20.0	11.0	10.0	3.0
2 HP	24.0	13.2	12.0	5.0
3 HP	34.0	18.7	17.0	5.0
5 HP	56.0	30.8	28.0	7.5
7.5 HP	80.0	44.0	40.0	15.0
10 HP	100	55.0	50.0	15.0
15 HP	135	74.8	68.0	25.0
20 HP	-	-	88.0	25.0
25 HP	-	-	110	37.5
30 HP	-	-	136	37.5
40 HP	-	-	176	50.0
50 HP	-	-	216	75.0

kVA ratings include 10% overcapacity for frequent motor starts.
* For 200 volt motors increase 220-240V ratings by 15%.



Selecting Transformers continued . . .

THREE PHASE

A three phase transformer is designed to transform a three phase input (source) voltage to the single phase and three phase output (load) voltages required by your equipment.

In order to select the correct three phase transformer you must first determine:

1) The equipment being installed operates on a **three phase** supply.

Note: If both single phase and three phase equipment makes up the load, the single phase equipment is connected to only one phase of the transformer.

2) The **Primary Voltage** of the transformer. This is the same as the line input (or source) voltage, typically 480 or 600 volts AC.

3) The **Secondary Voltage** of the transformer. This is the transformer's output voltage and must be the same as the voltage required by the equipment being installed (see equipment nameplate, typically 208Y/120 volts).

4) The **Frequency** in hertz (cycles per second) of the input (source) voltage must be the same as the operating frequency of the equipment being supplied. The transformer selected must operate at the same frequency. Typical operating frequency is 60 Hz.

5) The **Total VA** of the load is determined by the product of the voltage supplied across the load and the current passing through it. This is normally expressed in VA (Volt-Amperes) or kVA (kilo Volt-Amperes) on the equipment nameplate.

The total load is often a combination of various loads (i.e. lights, heaters, motors). You must calculate these individual loads and add them together to obtain the total load of the transformer.

The transformer you select must have a kVA rating equal to or greater than the load requirement. Note: The three phase transformer must be selected so that any one phase is not overloaded. If you are connecting a single phase load to one phase of the three phase transformer, you must calculate the load as if it were loading all three phases.

Calculating kVA

To calculate kVA when volts and amperes are known:

$$kVA = \sqrt{3} \times \frac{V_{LL} \times I_L}{1000}$$

V_{LL} = Volts line - line

I_L = Line Current

Full Load Current Table - Three Phase Transformer

kVA	Current in Amperes							
	208V	240V	380V	416V	480V	600V	2400V	4160V
2	5.55	4.81	3.03	2.77	2.40	1.92	0.48	0.27
3	8.32	7.21	4.55	4.16	3.60	2.88	0.72	0.41
6	16.6	14.4	9.11	8.32	7.21	5.77	1.44	0.83
9	24.9	21.6	13.6	12.4	10.8	8.66	2.16	1.24
15	41.6	36.0	22.7	20.8	18.0	14.4	3.60	2.08
30	83.2	72.1	45.5	41.6	36.0	28.8	7.21	4.16
45	124	108	68.3	62.4	54.1	43.3	10.8	6.24
75	208	180	113	104	90.2	72.1	18.0	10.4
112.5	312	270	170	156	135	108	27.0	15.6
150	416	360	227	208	180	144	36.0	20.8
225	624	541	341	312	270	216	54.1	31.2
300	832	721	455	416	360	288	72.1	41.6
450	1249	1082	683	624	541	433	108	62.4
500	1387	1202	759	693	601	481	120	69.3
600	1665	1443	911	832	721	577	144	83.2
750	2081	1804	1139	1040	902	721	180	104

Three Phase AC Motor Full Load Running Currents in Amperes and Recommended Transformer Ratings

Horsepower	Full Load Current (Amps) Minimum					Transformer kVA
	110-120V	208V	220-240V*	440-480V	550-600V	
.50 HP	4.0	2.2	2.0	1.0	0.8	3
.75HP	5.6	3.1	2.8	1.4	1.1	3
1 HP	7.2	4.0	3.6	1.8	1.4	3
1.5 HP	10.4	5.7	5.2	2.6	2.1	3
2 HP	13.6	7.5	6.8	3.4	2.7	6
3 HP	19.2	10.7	9.6	4.8	3.9	6
5 HP	30.4	16.7	15.2	7.6	6.1	9
7.5 HP	44.0	24.0	22.0	11.0	9.0	15
10 HP	56.0	31.0	28.0	14.0	11.0	15
15 HP	84.0	46.0	42.0	21.0	17.0	30
20 HP	108	59.0	54.0	27.0	22.0	30
25 HP	136	75.0	68.0	34.0	27.0	45
30 HP	160	88.0	80.0	40.0	32.0	45
40 HP	208	114	104	52.0	41.0	75
50 HP	260	143	130	65.0	52.0	75
60 HP	-	170	154	77.0	62.0	75
75 HP	-	211	192	96.0	77.0	112.5
100 HP	-	273	248	124	99.0	150

kVA ratings include 10% overcapacity for frequent motor starts.
* For 200 volt motors increase 220-240V ratings by 15%.



Compliance with Engineering Standards

HPS Dry-Type Transformers are approved, listed, recognized or comply with the following Regulatory Standards. The reference files are:

UL1561 and UL1562	CSA C9-M and CSA C22.2-M	
ANSI C57.12.51	NEMA TR-1 and ST-1	IEC 76

HPS dry-type transformers can be built to comply with the following engineering standards:

- ➔ **UL 1561** : Dry-Type General Purpose and Power Transformers
- ➔ **UL 1562** : Transformers, Distribution, Dry-Type over 600 volts
- ➔ **IEEE-C57.12.01** : General Requirements for Dry-Type Distribution and Power Transformers
- ➔ **NEMA ST-20** : Dry-Type Transformers for General Applications
- ➔ **ANSI-C57.12.51** : Requirements for Ventilated Dry-Type
- ➔ **ANSI-C57.12.70** : Terminal Markings & Connections for Distribution & Power Transformers
- ➔ **ANSI-C57.12.91** : Test Code for Dry-Type Distribution and Power Transformers
- ➔ **ANSI-C57.12.90** : Guide for Short Circuit Testing of Distribution and Power Transformers
- ➔ **NEMA 250** : Enclosures for Electrical Equipment
- ➔ **CSA-C22.2 No. 47** : Air-Cooled (Dry-Type) Transformers
- ➔ **CSA-C9-M** : Dry-Type Transformers
- ➔ **CSA C802.2 and DOE 10 CFR Part 431**: Energy Efficiency Standards

TRANSFORMER TEST STANDARDS

All transformers are fully tested at HPS prior to shipment. Transformers must meet a very exacting criteria to be certified acceptable for release. Tests are categorized as either 'Production Tests' or 'Type Tests'. Production Tests are performed on every HPS transformer.

Production Tests

D.C. Resistance Measurement

Current from a D.C. resistance bridge is applied to the transformers windings to determine the D.C. resistance voltage of the coils. This test is important for the calculation of I^2R for use in the winding temperature test and as base data for future assessment in the field.

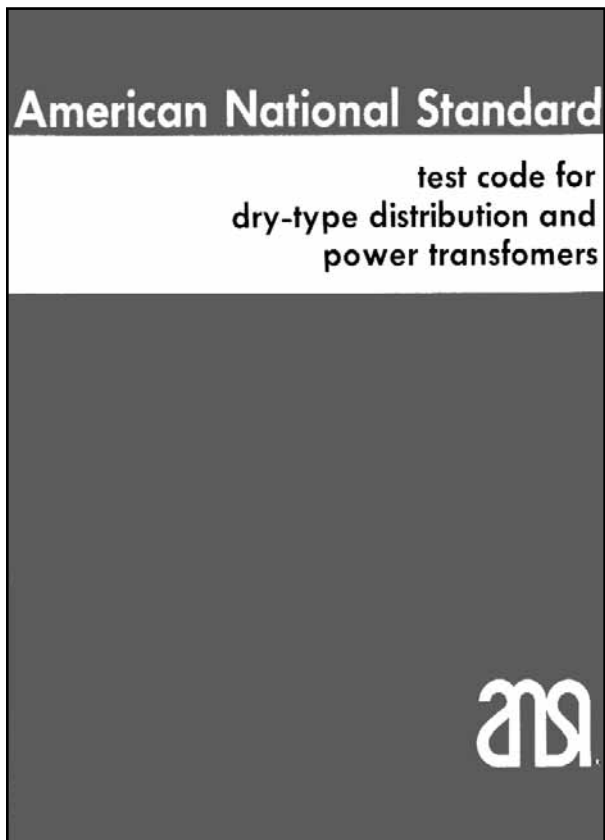

Polarity and Phase-Relation Test

Polarity and phase-relation tests are made to determine angular displacement and relative phase sequence to facilitate connections in a transformer. Determining polarity is also essential when paralleling or banking two or more transformers.

No-Load and Excitation Current Test*

No-load losses (excitation losses) are the core losses of a transformer that are "excited" at rated voltage and frequency, but which do not supply load. No-load losses include core loss, dielectric loss and losses in the windings due to exciting current.

The transformer is excited at rated voltage with all other windings open circuited. The exciting current and no load loss is then measured.

*(Note: This is a standard test only on units over 500kVA. It will only be carried out on lower kVA units when specifically requested.)

Voltage Ratio (turns ratio)

To confirm the voltage ratio of a transformer, the ratio of the number of turns in the high-voltage winding with respect to the number of turns in the low-voltage winding is measured .

INTRODUCTION

Transformer Test Standards continued ...

Impedance Voltage and Load Loss Test*

The voltage required to circulate the rated current under short-circuit conditions when connected on the rated voltage tap is the impedance voltage.

Rated current is circulated through the windings with the secondary short circuited. The impedance voltage and load loss is then measured. They are corrected to rise +20°C reference temperature.

*(Note: This is a standard test only on units over 500kVA. It will only be carried out on lower kVA units when specifically requested.)

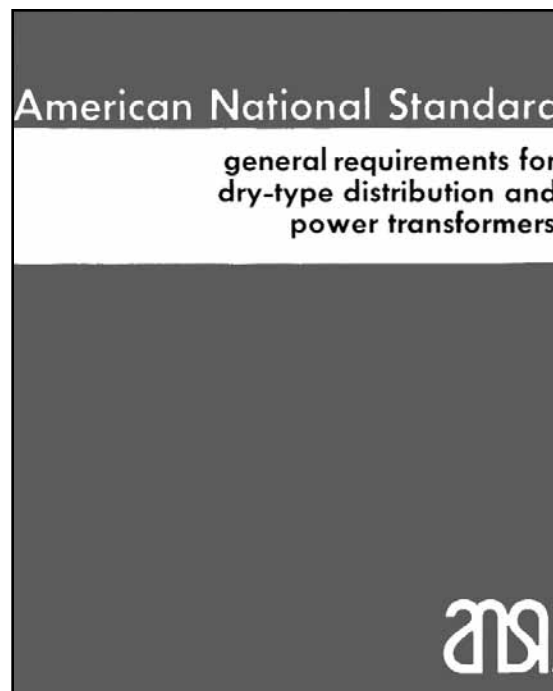
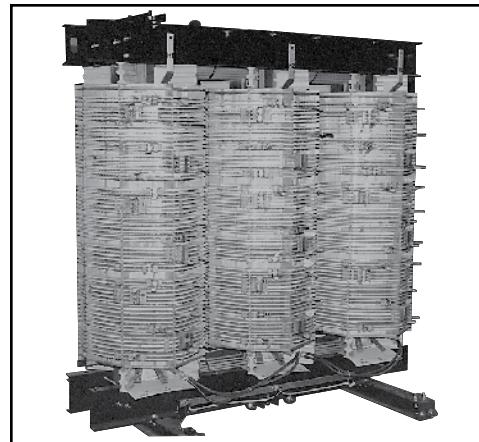

Dielectric Tests

The purpose of dielectric tests is to demonstrate that the transformer has been designed and constructed to withstand the voltages associated with specified insulation levels.

Applied Voltage Test

A normal power frequency, such as 60 Hz, is applied to each winding for one minute. These tests are in accordance with table (3) in ANSI C57-12-01.

Induced Voltage Test

The induced voltage test is applied for 7200 cycles or 60 seconds, whichever is shorter. The voltage applied is twice the operating voltage and confines the integrity of the insulation.

Type Tests

Type tests are required either to qualify a new product or to further certify a standard product line. The following is a list of type tests performed on HPS Transformers.

- Temperature Rise Test
- Sound Level Test
- Partial Discharge (corona)
- Basic Impulse Insulation Level (BIL)
- Short-Circuit Test

QUALITY MANAGEMENT SYSTEMS

ISO 9001:2008

Hammond Power Solutions facilities, located in Guelph Ontario Canada, Walkerton Ontario Canada, Baraboo Wisconsin USA, Compton California USA and Monterrey Mexico, (which manufacture the transformers featured in this catalog), have implemented Quality Management Systems based on ISO 9001. ISO 9001 includes all processes affecting quality, customer satisfaction and continual improvement. Our customers can be assured of the integrity and quality in all Hammond Power Solutions transformer products.



HPS STANDARD ENCLOSURES

An enclosure is a surrounding case constructed to provide a degree of protection to personnel against access to hazardous parts and to provide a degree of protection to the enclosed equipment against specified environmental conditions.

Applicable Engineering Standards

HPS Enclosures are designed in accordance with the following standards:

- CSA 22.2 No. 47 (General Purpose)
- CSA 22.2 No. 94 (Specialty Enclosures)
- NEMA 250
- UL 50 and UL 50E

Please ensure to reference all local and national electrical codes and applicable transformer standards before selecting an enclosure for your application.

Definitions

- Degree of protection:** The extent of protection provided by an enclosure against access to hazardous parts, against ingress of foreign solid objects and/or against ingress of water and verified by approved standardized test methods.
- Hazardous parts:** A part that is hazardous to approach or to touch.
- Indoor Locations:** Areas which are protected from exposure to the weather.
- Non-ventilated:** Constructed so as to provide no intentional circulation of external air through the enclosure.
- Outdoor locations:** Locations that are exposed to the weather.
- Ventilated:** Constructed so as to provide for the circulation of external air through the enclosure to remove excess heat, fumes or vapors.

Enclosure Selection

The selection of the appropriate enclosure is vital for the long term reliability of your HPS product. The "degree of protection" an enclosure actually provides can only be determined by referencing the appropriate test methods outlined in the above mentioned standards.

The list below is just some of the typical enclosure types available for HPS products, their applications, and the environmental conditions they are designed to meet.

HPS Typical Enclosures Types

The following lists some of the standard HPS enclosures available and a brief description of their applications:

TYPE 1

This is a general purpose ventilated enclosure constructed for indoor use only to provide a degree of protection to personnel against access to hazardous parts; to provide a degree of protection of the equipment inside the enclosure against ingress of solid foreign objects (falling dirt).

TYPE 2

This is a general purpose ventilated enclosure constructed for indoor use only to provide a degree of protection to personnel against access to hazardous parts; to provide a degree of protection of the equipment inside the enclosure against the ingress of solid foreign objects (falling dirt); and to provide a degree of protection with respect to harmful effects on the equipment due to the ingress of water (dripping or light splashing).

TYPE 3RI

This is a general purpose ventilated enclosure constructed for indoor use only to provide a degree of protection to personnel against access to hazardous parts; to provide a degree of protection of the equipment inside the enclosure against the ingress of solid foreign objects (falling dirt); and to provide a degree of protection with respect to harmful effects on the equipment due to the ingress of water (sprinkler head spray, light splashing of liquids).

TYPE 3R

This is a general purpose ventilated enclosure constructed for either indoor or outdoor use to provide a degree of protection to personnel against access to hazardous parts; to provide a degree of protection of the equipment inside the enclosure against the ingress of solid foreign objects (falling dirt); and to provide a degree of



INTRODUCTION

HPS Standard Enclosures continued ...

protection with respect to harmful effects on the equipment due to the ingress of water (rain, sleet, snow); and that will be undamaged by the external formation of ice on the enclosure.

TYPE 3RE

This is a general purpose ventilated enclosure constructed for either indoor or outdoor use to provide a degree of protection to personnel against access to hazardous parts; to provide a degree of protection of the equipment inside the enclosure against the ingress of solid foreign objects (falling dirt and circulating dust); and to provide a degree of protection with respect to harmful effects on the equipment due to the ingress of water (rain, sleet, circulating snow); and that will be undamaged by the external formation of ice on the enclosure.

TYPE 4

This is a general purpose non-ventilated enclosure constructed for either indoor or outdoor use to provide a degree of protection to personnel against access to hazardous parts; to provide a degree of protection of the equipment inside the enclosure against the ingress of solid foreign objects (falling dirt and windblown dust); and to provide a degree of protection with respect to harmful effects on the equipment due to the ingress of water (rain, sleet, snow, splashing water, and hose directed water); and that will be undamaged by the external formation of ice on the enclosure. (Note: not submersible)

TYPE 4X

This is a general purpose non-ventilated enclosure constructed for either indoor or outdoor use to provide a degree of protection to personnel against access to hazardous parts; to provide a degree of protection of the equipment inside the enclosure against the ingress of solid foreign objects (windblown dust); and to provide a degree of protection with respect to harmful effects on the equipment due to the ingress of water (rain, sleet, snow, splashing water, and hose directed water); that provides an additional level of protection against corrosion; and that will be undamaged by the external formation of ice on the enclosure. (Note: not submersible)

TYPE 12

This is a general purpose non-ventilated enclosure constructed (without knockouts) for indoor use only to provide a degree of protection to personnel against access to hazardous parts; to provide a degree of protection of the equipment inside the enclosure against the ingress of solid foreign objects (falling dirt and circulating dust, lint, fibers, and filings); and to provide a degree of protection with respect to harmful effects on the equipment due to the ingress of water (dripping and light splashing). (Note: not submersible)

CONVERSION OF NEMA ENCLOSURE TYPE RATINGS TO IEC 60529 ENCLOSURE CLASSIFICATION DESIGNATIONS (IP)

(Cannot be Used to Convert IEC Classification Designations to NEMA Type Ratings)

IP 1st Character	NEMA Enclosure Type																IP 2nd Character		
	1	2	3, 3X, 3S,3SX	3R, 3RX	4, 4X	5	6	6P	12, 12K, 13										
IP0_																			IP_0
IP1_																			IP_1
IP2_																			IP_2
IP3_																			IP_3
IP4_																			IP_4
IP5_																			IP_5
IP6_																			IP_6
																			IP_7
																			IP_8
	A	B	A	B	A	B	A	B	A	B	A	B	A	B	A	B	A	B	

IP First Character = The A shaded block in the "A" column represents the first IP character. This indicates that the NEMA Enclosure Type exceeds the requirements for the respective IEC 60529 IP First Character Designation. This IP First Character Designation is the protection against access to hazardous parts and solid foreign objects.

IP Second Character = The B shaded block in the "B" column represents the second IP character. This indicates that the NEMA Enclosure Type exceeds the requirements for the respective IEC 60529 IP Second Character Designation. This IP First Character Designation is the protection against the ingress of water.

Example: NEMA Type 3R = IP24

Note: Please refer to NEMA standards publication 250-2003 for exact details of the above table.



INTRODUCTION

HAMMOND POWER SOLUTIONS INC. EXCLUSIVE LIMITED WARRANTY

Exclusive Warranty

Hammond Power Solutions Inc. (“HPS”), warrants to the original purchaser of the standard transformers listed in this catalog (the “Goods”), will be free from defects in materials and workmanship for a period commencing on the date of manufacture of the Goods and expiring at the end of the period specified below (the “Warranty Period”). THIS WARRANTY IS EXCLUSIVE AND IS IN LIEU OF ANY OTHER WARRANTY EXPRESS OR IMPLIED, INCLUDING BUT NOT LIMITED TO ANY IMPLIED WARRANTY OR MERCHANTABILITY OR FITNESS FOR A PARTICULAR PURPOSE.

Warranty Exclusions - Limitation of Damages and Claims Procedure

The above stated warranty does not cover: workmanship of installation; dissatisfaction or damage due to improper installation, vandalism, misuse, accident, excessive wear and tear, unauthorized repair, abnormal use, lack of maintenance, or other cause(s) not within HPS’s control and HPS WILL NOT BE LIABLE, UNDER ANY CIRCUMSTANCES, FOR CONSEQUENTIAL OR INCIDENTAL DAMAGES, INCLUDING BUT NOT LIMITED TO LABOR COSTS OR LOST PROFITS RESULTING FROM THE USE OF OR INABILITY TO USE THE GOODS OR FROM THE GOODS BEING INCORPORATED IN OR BECOMING A COMPONENT OR ANY OTHER PRODUCT. Without limiting the generality of the foregoing, HPS will not be responsible for labor costs involved in the removal of Goods or the installation of replacement Goods.

HPS’s liability and the Buyer’s exclusive remedy hereunder will be limited to repair or replacement of those Goods found in HPS’s reasonable judgment to be defective. HPS reserves the right to accept or reject any claim in whole or in part. HPS will not accept the return of any Goods without its prior written approval. Please consult HPS for instructions on the Return Authorization procedure.

Product Warranty Periods:

Industrial Control Transformers (Section 1)

HPS Imperator®	Lifetime Warranty
HPS Spartan®	15 Years
Other Control	10 Years
HPS Fusion™ General Purpose Enclosed Transformers (Section 1)	15 Years
HPS Universal™ Buck-Boost/Low Voltage Lighting Transformers (Sections 2 & 6)	10 Years
Line Reactors and DV/DT Filters (Section 3)	10 Years
HPS Tribune™ and Standard Drive Isolation Transformers (Section 4)	10 Years
Motor Starting Auto Transformers (Section 5)	1 Year
Energy Efficient Distribution Transformers (Section 7)	10 Years
Encapsulated Dry-Type Distribution Transformers (Section 8)	10 Years
HPS PowerPlus™ Mini Power Center (Section 9)	
Transformer only	15 Year
Mini Power Center	1 Year
Autotransformers (Section 10)	10 Years
HPS Millennium Medium Voltage Distribution Transformers (Section 11)	1 Year
All HPS six digit Special and Custom Transformers	1 Year





SECTION 1

INDUSTRIAL CONTROL AND GENERAL PURPOSE ENCLOSED TRANSFORMERS

HPS Imperator[®], HPS Spartan[®], HPS Fusion[™] and Q Series Transformers

Control Transformer Quick Selection Charts	30
What Is A Control Transformer?	31
Overcurrent Protection	32
 <u>HPS Imperator Machine Tool Industrial Control Transformers</u>	
Features and Benefits	36
Selection Tables	38
Optional Accessories	45
Wiring Schematics	64
 <u>HPS Spartan Industrial Open-Style Core & Coil Control Transformers</u>	
Features and Benefits	47
Selection Tables	48
Optional Accessories	53
Wiring Schematics	75
 <u>HPS Fusion General Purpose Enclosed Transformers</u>	
Features and Benefits	55
Selection Tables	56
Optional Accessories	61
Wiring Schematics	75
 <u>Q Series Enclosed Potted Control Transformers</u>	
Features and Benefits	62
Selection Table	63
Wiring Schematics	277

SECTION 1

TRANSFORMER QUICK SELECTION CHARTS

HPS Imperator®

Pri. Volts	Sec. Volts	Group	Part No.	Page
600, 575, 550	120 x 240, 115 x 230, 110 x 220	A	PH***AJ	38
600, 575, 550	12 x 24, 11.5 x 23, 11 x 22	B	PH***AR	38
240 x 480, 230 x 460, 220 x 440	120 x 240, 115 x 230, 110 x 220	C	PH***MQMJ	39
240 x 480, 230 x 460, 220 x 440	12 x 24, 11.5 x 23, 11 x 22	D	PH***QR	39
208 x 416, 200 x 400, 190 x 380	120 x 240, 115 x 230, 110 x 220	E	PH***SP	40
120 x 240, 115 x 230, 110 x 220	120 x 240, 115 x 230, 110 x 220	F	PH***PP	40
120 x 240, 115 x 230, 110 x 220	12 x 24, 11.5 x 23, 11 x 22	G	PH***PG	41
600/480/240, 575/460/230, 550/440/220	120/100, 115/95, 110/90	H	PH***MBMH	41
480/240, 460/230/208, 440/220/200	120/25, 115/24, 110/23	I	PH***MLI	42
415/400/380	110 x 220	J	PH***MEMX	42
380/277/208	120 x 240	K	PH***MGJ	43

HPS Spartan®

Pri. Volts	Sec. Volts	Group	Part No.	Page
600/480, 575/460, 550/440	120 x 240, 115 x 230, 110 x 220	A	SP***ACP	48
600, 575, 550	12 x 24, 11.5 x 23, 11 x 22	B	SP***AR	48
240 x 480, 230 x 460, 220 x 440	120 x 240, 115 x 230, 110 x 220	C	SP***MQMJ	49
240 x 480, 230 x 460, 220 x 440	12 x 24, 11.5 x 23, 11 x 22	D	SP***QR	49
347/380	120 x 240	E	SP***KHP	50
347/380	12 x 24	F	SP***KHR	50
277	120	G	SP***NJ	51
120 x 240, 115 x 230, 110 x 220	12 x 24, 11.5 x 23, 11 x 22	H	SP***PR	51
208 x 416, 200 x 400, 190 x 380	120 x 240, 115 x 230, 110 x 220	I	SP***SP	52
208 x 416, 200 x 400, 190 x 380	12 x 24, 11.5 x 23, 11 x 22	J	SP***SR	52

HPS Fusion™

Pri. Volts	Sec. Volts	Group	Part No.	Page
600/480, 575/460, 550/440	120 x 240, 115 x 230, 110 x 220	A	FS***ACP	56
600, 575, 550	12 x 24, 11.5 x 23, 11 x 22	B	FS***AR	56
240 x 480, 230 x 460, 220 x 440	120 x 240, 115 x 230, 110 x 220	C	FS***MQMJ	57
240 x 480, 230 x 460, 220 x 440	12 x 24, 11.5 x 23, 11 x 22	D	FS***QR	57
347/380	120 x 240	E	FS***KHP	58
347/380	12 x 24	F	FS***KHR	58
277	120	G	FS***NJ	59
120 x 240, 115 x 230, 110 x 220	12 x 24, 11.5 x 23, 11 x 22	H	FS***PR	59
208 x 416, 200 x 400, 190 x 380	120 x 240, 115 x 230, 110 x 220	I	FS***SP	60
208 x 416, 200 x 400, 190 x 380	12 x 24, 11.5 x 23, 11 x 22	J	FS***SR	60

Q Series

Pri. Volts	Sec. Volts	Part No.	Page
600	12/24	Q***PRC*	63



WHAT IS A CONTROL TRANSFORMER?

What is a Control Transformer?

A control transformer is an isolation transformer designed to provide a high degree of secondary voltage stability (regulation) during a brief period of overload condition (also referred to as “*inrush current*”). Control transformers are also known as *Machine Tool Transformers*, *Industrial Control Transformers* or *Control Power Transformers*.

When you calculate the VA requirement of a Transformer, do you use the Primary or the Secondary Voltage?

When selecting the VA requirement, you use the Secondary Voltage.

Can you use a Control Transformer connected in reverse?

Yes, a control transformer can be connected in reverse. However, keep in mind the output voltage will be less than its rating, due to the compensation factor of the windings.

Can a Control Transformer regulate the output voltage?

A control transformer will not regulate the voltage. Output voltage is a function of the coil's turn ratio only, times the input voltage.

What is the benefit of “Vacuum Impregnation” on a Transformer?

All HPS Control Transformers are vacuum impregnated with “VT Polyester Resin” and oven cured which seals the surface and eliminates moisture. Impregnating the entire unit provides a strong mechanical bond and offers protection from environmental conditions.

Explain the “VA” or “Volt Ampere Output” Rating?

The VA or volt ampere output rating designates the output which a transformer can deliver for a specified time at its rated secondary voltage and rated frequency, without exceeding its specified temperature rise.

Insulating Materials; what are they made of and what is their purpose?

Hammond Power Solutions utilizes Mylar, Nomex and other high quality insulating materials. Insulation is used to electrically insulate turn-to-turn windings, layer-to-layer windings, primary to secondary windings and ground.

What is the effect of “Overload”?

When a transformer is continually overloaded, excessive heat develops and the insulation system will begin to breakdown. As a result, the life expectancy of the transformer is shortened due to the heat exceeding the rating of the insulation system.

Recommendations For Overcurrent Protection

UL AND CSA (NORTH AMERICAN) STANDARDS

North American standards, including UL 508, National Electric Code 450 and the Canadian Electrical Code Part I, require overcurrent protection on all control circuit transformers. There are two options for overcurrent protection:

Option 1

Provide an overcurrent device in the primary circuit rated to the current of the transformer. The overcurrent limits are as follows:

Primary 9 amps or more:	no more than 125% of rated current.
Primary 2 to 9 amps:	no more than 167% of rated current.
Primary less than 2 amps:	no more than 300% of rated current for power circuits. no more than 500% of rated current for control circuits.

This method is considered less desirable as start-up inrush to the transformer can frequently surpass the current rating of the device and result in nuisance interruptions.

Option 2

The second option is to install overcurrent devices in both the primary and secondary circuits of the transformer. In this option, the secondary device must be rated no more than 125% of rated current of the transformer and the primary no more than 250%. CEC permits 300% overcurrent on the primary for this option.

In both options listed, it is recommended that **time delay** fuses be considered to avoid unnecessary interruptions.

Secondary

The overcurrent protection listed below, in amperes, is 125% of the rated current of the transformer. Choose the next higher fuse rating if these numbers do not correspond with standard fuse selections.

Sec. Voltage	VA Rating															
	25	50	75	100	150	200	250	300	350	500	750	1000	1500	2000	3000	5000
12	2.7	5.3	7.9	11	16	21	27	-	-	-	-	-	-	-	-	-
24	1.4	2.7	4.0	5.3	7.9	11	14	16	19	27	-	-	-	-	-	-
90	0.4	0.7	1.1	1.4	2.1	2.8	3.5	4.2	4.9	7.0	11	14	21	28	-	-
95	0.4	0.7	1.0	1.4	2.0	2.7	3.3	4.0	4.7	6.6	9.9	14	20	27	-	-
100	0.4	0.7	1.0	1.3	1.9	2.5	3.2	3.8	4.4	6.3	9.4	13	19	25	-	-
110	0.3	0.6	0.9	1.2	1.8	2.3	2.9	3.5	4.0	5.7	8.6	12	18	23	-	-
115	0.3	0.6	0.9	1.1	1.7	2.2	2.8	3.3	3.9	5.5	8.2	11	17	22	-	-
120	0.3	0.6	0.8	1.1	1.6	2.1	2.7	3.2	3.7	5.3	7.9	11	16	21	-	-
220	0.15	0.3	0.5	0.6	0.9	1.2	1.5	1.8	2.0	2.9	4.3	5.7	8.6	12	18	29
230	0.14	0.3	0.5	0.6	0.9	1.1	1.4	1.7	2.0	2.8	4.1	5.5	8.2	11	17	28
240	0.14	0.3	0.4	0.6	0.8	1.1	1.4	1.6	1.9	2.7	4.0	5.3	7.9	11	16	27

Recommendations for Overcurrent Protection

Primary (UL and CSA)

To assist in the selection of fuses, the following chart recommends the maximum primary fuse rating in amperes. The first number shown is the maximum overcurrent protection when the primary current is less than 2 amps and the overcurrent protection device is rated for 300%. The second number shown (*italic*) is recommended when the primary is less than 2 amps and the overcurrent device is to be rated at 500% of rated current. Where only one number is indicated, the primary is 2 amps or more and one rating of over current protection is shown as optimal. Choose the next higher fuse rating if these numbers do not correspond with standard fuse selections.

Pri. Volt	VA Rating																
	25	50	75	100	150	200	250	300	350	500	750	1000	1500	2000	3000	5000	7500
115	0.6	1.25	1.8	2.5	3.5	5	4	5	5	8	10	15	20	25	-	-	-
	<i>1</i>	<i>2</i>	<i>3.2</i>	<i>4</i>	<i>6.25</i>	<i>8</i>											
120	0.6	1.25	1.8	2.25	3.5	5	4	5	5	8	10	15	15	20	-	-	-
	<i>1</i>	<i>2</i>	<i>3</i>	<i>4</i>	<i>6.25</i>	<i>8</i>											
200	0.3	0.75	1.125	1.5	2.25	3	3.5	4.5	5	4.5	7	9	15	15	20	-	-
	<i>0.6</i>	<i>1.25</i>	<i>1.8</i>	<i>2.5</i>	<i>3.5</i>	<i>5</i>	<i>6.25</i>	<i>7.5</i>	<i>8</i>								
208	0.3	0.6	1	1.4	2	2.8	3.5	4	5	4	6	8	12	15	20	30	-
	<i>0.6</i>	<i>1.125</i>	<i>1.8</i>	<i>2.25</i>	<i>3.5</i>	<i>4.5</i>	<i>6</i>	<i>7</i>	<i>8</i>								
220	0.3	0.6	1	1.25	2	2.5	3.2	4	4.5	4	6	8	12	15	20	30	-
	<i>0.5</i>	<i>1.125</i>	<i>1.6</i>	<i>2.25</i>	<i>3.2</i>	<i>4.5</i>	<i>5.6</i>	<i>6.25</i>	<i>7.5</i>								
230	0.3	0.6	0.8	1.25	1.8	2.5	3.2	3.5	4.5	4	6	8	10	15	20	30	-
	<i>0.5</i>	<i>1</i>	<i>1.6</i>	<i>2</i>	<i>3.2</i>	<i>4</i>	<i>5</i>	<i>6.25</i>	<i>7.5</i>								
240	0.3	0.6	0.8	1.25	1.8	2.25	3	3.5	4	3.5	5	7	10	15	15	30	-
	<i>0.5</i>	<i>1</i>	<i>1.5</i>	<i>2</i>	<i>3</i>	<i>4</i>	<i>5</i>	<i>6.25</i>	<i>7</i>								
277	0.25	0.5	0.8	1	1.6	2	2.5	3.2	3.5	5	5	6	9	12	15	25	-
	<i>0.4</i>	<i>0.8</i>	<i>1.25</i>	<i>1.8</i>	<i>1.5</i>	<i>3.5</i>	<i>4.5</i>	<i>5</i>	<i>6.25</i>	<i>9</i>							
347	0.25	0.5	0.8	1	1.6	2	2.5	3.2	3.5	5	6.25	5	7.5	10	15	20	30
	<i>0.4</i>	<i>0.8</i>	<i>1.25</i>	<i>1.8</i>	<i>2.5</i>	<i>3.5</i>	<i>4.5</i>	<i>5</i>	<i>6.25</i>	<i>9</i>							
380	0.1875	0.3	0.5	0.75	1.125	1.5	1.8	2.25	2.5	3.5	5.6	4.5	6.25	9	15	20	25
	<i>0.3</i>	<i>0.6</i>	<i>0.8</i>	<i>1.25</i>	<i>1.8</i>	<i>2.5</i>	<i>3.2</i>	<i>3.5</i>	<i>4.5</i>	<i>6.25</i>	<i>9</i>						
400	0.1875	0.3	0.5	0.75	1.125	1.5	1.8	2.25	2.5	3.5	5.6	4.5	6.25	9	12	15	20
	<i>0.3</i>	<i>0.6</i>	<i>0.8</i>	<i>1.25</i>	<i>1.8</i>	<i>2.5</i>	<i>3</i>	<i>3.5</i>	<i>4</i>	<i>6.25</i>	<i>9</i>						
416	0.15	0.3	0.5	0.6	1	1.4	1.8	2	2.5	3.5	5	4	6	8	12	15	20
	<i>0.3</i>	<i>0.6</i>	<i>0.8</i>	<i>1.125</i>	<i>1.8</i>	<i>2.25</i>	<i>3</i>	<i>3.5</i>	<i>4</i>	<i>6</i>	<i>9</i>						
440	0.15	0.3	0.5	0.6	1	1.25	1.6	2	2.25	3.2	5	4	6	8	12	15	20
	<i>0.25</i>	<i>0.5</i>	<i>0.8</i>	<i>1.125</i>	<i>1.6</i>	<i>2.25</i>	<i>2.8</i>	<i>3.2</i>	<i>3.5</i>	<i>5.6</i>	<i>8</i>						
460	0.15	0.3	0.4	0.6	0.8	1.25	1.6	1.8	2.25	3.2	4.5	3.5	6	8	12	15	20
	<i>0.25</i>	<i>0.5</i>	<i>0.8</i>	<i>1</i>	<i>1.6</i>	<i>2</i>	<i>2.5</i>	<i>3.2</i>	<i>3.5</i>	<i>5</i>	<i>8</i>						
480	0.15	0.3	0.4	0.6	0.8	1.25	1.5	1.8	2	3	4.5	3.5	5	7	10	15	20
	<i>0.25</i>	<i>0.5</i>	<i>0.75</i>	<i>1</i>	<i>1.5</i>	<i>2</i>	<i>2.5</i>	<i>3</i>	<i>3.5</i>	<i>5</i>	<i>7.5</i>						
550	0.125	0.25	0.4	0.5	0.8	1	1.25	1.6	1.8	2.5	4	5	4.5	6	9	15	15
	<i>0.2</i>	<i>0.4</i>	<i>0.6</i>	<i>0.8</i>	<i>1.25</i>	<i>1.8</i>	<i>2.25</i>	<i>2.5</i>	<i>3</i>	<i>4.5</i>	<i>6.25</i>						
575	0.125	0.25	0.3	0.5	0.75	1	1.25	1.5	1.8	2.5	3.5	5	4.5	6	9	15	15
	<i>0.2</i>	<i>0.4</i>	<i>0.6</i>	<i>0.8</i>	<i>1.25</i>	<i>1.6</i>	<i>2</i>	<i>2.5</i>	<i>3</i>	<i>4</i>	<i>6.25</i>						
600	0.125	0.2	0.3	0.5	0.75	0.8	1.25	1.5	1.6	2.25	3.5	5	4	6	9	15	15
	<i>0.2</i>	<i>0.4</i>	<i>0.6</i>	<i>0.8</i>	<i>1.25</i>	<i>1.6</i>	<i>2</i>	<i>2.5</i>	<i>2.8</i>	<i>4</i>	<i>6.25</i>						

References: UL 508, 32.7
 UL 845, 11.16 and 11.17
 NEC 430-72 (c) exception #2
 NEC 450-3 (b) 1 and 2
 CEC Part I, 26-256



HPS Imperator® Machine Tool Industrial Control Transformer

The Perfect Solution

The HPS Imperator line of machine tool industrial control transformers are specifically designed to meet the high inrush industrial applications where electromagnetic components such as relays, solenoids etc. are used.

- 11 standard voltage groups
- VA range from 50VA to 1500VA
- Available with standard secondary and optional primary fuse kits
- Optional finger safe terminal covers
- Patented unique terminal block design
- Innovative fusing method
- Lifetime warranty (limited)

The HPS Imperator provides the perfect solution for any applications.

Superior Quality and Value

The HPS Imperator design, utilizing superior insulation systems and being constructed with high quality silicon steel laminations for optimum performance, will meet or exceed UL and CE standards.

Backed by an industry leading LIFETIME warranty, the HPS Imperator industrial control transformer line offers superior performance, quality and value.



STANDARDS		
HPS Imperator Series Control Transformers meet or exceed the standards established by UL, IEC, and NEMA.		
<u>Standard</u>	<u>File #</u>	<u>VA Size</u>
UL (ANSI/UL 506)	E50394	All
IEC 61558		All (excluding PH***AJ & PH***AR)
NEMA (ST-1)		All



At HPS, we rate the VA capacity of our transformers at the output where it counts. Other transformer manufacturers rate their capacity on the input side of the transformer, which can result in a 5% to 20% lower actual VA at the output.

MACHINE TOOL INDUSTRIAL CONTROL TRANSFORMER SELECTION

Selecting a Control Transformer requires that you have first hand knowledge of the application for the transformer and that you understand some basic terms related to the selection process. By using the following information, you will be sure to select the HPS Imperator® Control Transformer which best meets your application.

The HPS Imperator Series machine tool control transformers are specifically designed for high inrush applications requiring reliable output voltage stability. Designed to meet industrial applications where electromagnetic devices such as relays, solenoids, etc. are used, the HPS Imperator series transformers maximize inrush capability and output voltage regulation when electromagnetic devices are initially energized.

To select the proper transformer, three characteristics of the load circuit must first be determined. They are total steady-state (sealed) VA, total inrush VA, and inrush load power factor.

(A) The total steady state “sealed” VA is the amount of VA that the transformer must supply to the load circuit for an extended length of time. Simply add the total steady-state VA of all devices in your control circuit. The operating VA data of these components is available from the manufacturers.

(B) The total inrush VA is the amount of VA that the transformer must supply for all components in the control circuit which are energized together. Some consideration to the start-up sequence may be required. Inrush VA should be obtained from the device manufacturer.

(C) The inrush load power factor is difficult to determine without detailed vector analysis of all the control circuit components. Such information

is not generally available. Therefore, HPS is recommending that a 40% power factor be utilized. Although some other control transformer manufacturers still recommend a power factor of only 20%, HPS, through recent tests conducted on many popular brands of control devices, has determined that the 40% power factor value is more accurate.

Once the above circuit variables have been determined, transformer selection is a six step process.

SIX EASY STEPS

1. Determine what your Primary (supply) and Secondary (output) voltage requirements are, as well as your required frequency (i.e. 60 Hz)

2. Calculate the Total Sealed VA of your circuit. (See Step A)

3. Calculate the Inrush VA by adding the inrush VA of all components being energized together. Remember to add the sealed VA of all components that do not have inrush VA, (lamps, timers etc.) as they present a load to the transformer during maximum inrush. If the inrush for the components in your circuit are not known, assume a 40% Inrush Power Factor.

4. Calculate the Total Inrush VA using one of the two methods:

A.
$$\text{Total Inrush VA} = \sqrt{(\text{VA sealed})^2 + (\text{VA inrush})^2}$$

OR

B.
$$\text{Total Inrush VA} = \text{VA Sealed} + \text{VA Inrush}$$

Note: method B will result in a slightly larger transformer being selected.

For VA sealed definition please refer to 1 (A).
For VA inrush definition please refer to 1 (B).

5. If the nominal supply voltage does not fluctuate more than 5%, then reference the 90% secondary voltage column in the Regulation Data Table for the correct VA rating.

If the supply voltage varies upwards of 10%, the 95% secondary voltage column should be used to size the transformer.

Current standards require electromagnetic devices to operate reliably at a minimum of 85% of their rated voltage. However, contact life may be affected with continuous start-ups at that voltage level. Therefore, the minimum 85% secondary voltage column should only be used as a reference.

6. Using the regulation data tables below, select the appropriate VA rated transformer:

A) With a continuous VA rating that is equal to or greater than the value in Step 2.

B) With a maximum inrush VA equal to or greater than the value obtained in Step 4.

To determine the correct HPS Transformer and its Catalog Number, just refer to the tables in this catalog for the voltage ratings, frequency and corresponding VA required.

**HPS IMPERATOR® TRANSFORMERS
REGULATION DATA TABLE**

Continuous VA Transformer Nameplate Rating	Inrush VA @ 40% Power Factor		
	85% Secondary Voltage	90% Secondary Voltage	95% Secondary Voltage
50	330	259	192
75	350	258	170
100	620	467	321
150	895	699	512
250	1596	1229	880
350	2464	1889	1345
500	3939	2854	1819
750	6422	4778	3228
1000	9842	7102	4530
1500	12797	9018	5489

It is recommended that a Control Transformer be sized at a 40% Power Factor. Some components in a circuit, such as electromagnetic devices, typically operate at that level due to their inherently lower power factor. Selecting a transformer at 40% Power Factor will more than adequately size the unit for all the various loads in the circuit.



FEATURES & BENEFITS

- 600V class, machine tool rated industrial control transformers
- 11 standard multi primary and secondary voltage groups available¹
- 50/60 Hertz (60Hz on PH***AJ & PH***AR)
- VA range from 50 to 1500¹
- Superior insulation system
 - 50-150VA, temperature rise 55°C, insulation class 105°C
 - 250-1500VA, temperature rise 80°C, insulation class 130°C
- Constructed with high quality silicon steel laminations that provide optimum performance and reliability
- Encapsulated copper wound coils encased in a custom injection molded cover, protects coils and terminations from moisture, dirt and other industrial airborne contaminants
- Mounting Feet: made of heavy steel and welded or bolted to the core, these mounting feet provide superior strength in a compact design.
- Termination: combination slot/Phillips #6 screw, complete with SEMS washer (suitable for 18 AWG to 14 AWG solid or 14 AWG stranded wire)
- Standard SEMS washers - supplied on all units²
- Standard secondary fuse kits - utilizing 13/32" x 1 1/2" midget/type CC fuse clips
- Optional primary fuse kits available utilizing 13/32" x 1 1/2" midget/type CC fuse clips
- Optional finger safe terminal covers available on all units
- Seismically certified in accordance with 2009 IBC for $S_{DS} \leq 2.00g$, $z/h = 1.0$ and $I_p = 1.5$
- UL Listed (approved for U.S. and Canada)
- CE Mark standard on all units (excluding PH*AR and PH*AJ)
- LIFETIME Warranty (Limited)
- RoHS Compliant

¹ special voltages and VA sizes available upon request
² excluding PH750PG, PH1000PG, PH750MLI, PH1000MLI

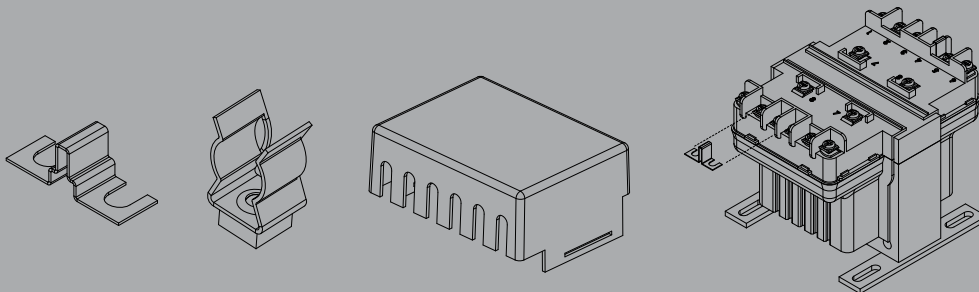
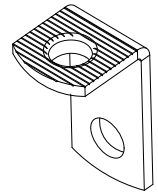
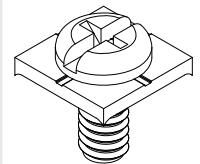

WARRANTY

Lifetime

FEATURES & BENEFITS CONTINUED

Terminal connection numbers molded into the terminal block and correspond to the nameplate and wiring diagrams, make connecting the HPS Imperator quick and simple.



SEMS washer allows for easy connection of supply or load wires with or without terminal connectors.

Standard secondary and optional primary fuse kits utilizing 13/32" x 1 1/2" midget/type CC fuse clips provide an economical solution to your fusing requirements (fuses not available).



Innovative terminal block design provides for easy hook-up and installation of fuse clips.

Optional removable finger safe terminal covers available on all units.

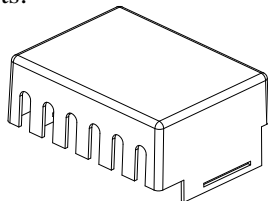

Custom injection molded coil cover with its unique "fin shaped" design combines superior cooling properties with a clean, bold look.

Made of heavy steel and welded or bolted to the core, these mounting feet provide superior strength in a compact design.

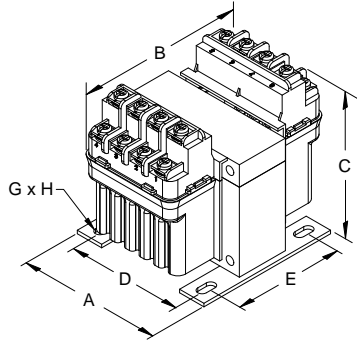

FIGURE A

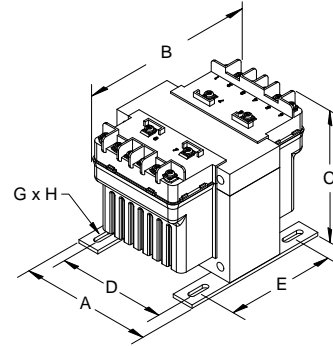

FIGURE B

Group A

Primary Voltage: **600** || **575** || **550**  **60 Hertz**
 Secondary Voltage: **120 X 240** || **115 X 230** || **110 X 220**

VA Rating	Catalog Number	Mtg. Fig.	Output Amps	Overall Dimensions			Mounting Centers		Mounting Slot	Height with Finger Guard	Depth with Finger Guard	Approx. Ship Weight Lbs.	Optional Primary Fuse Kit P/N	Optional Unfused and Fused Finger Guard Kit P/N
				A	B	C	D	E	G X H					
50	PH50AJ	A	0.42/0.21	3.00	3.81	3.19	2.50	2.25	0.22 x 0.44	4.00	5.25	2.70	PFK1	FG1*/FGF1
75	PH75AJ	A	0.63/0.31	3.25	3.69	3.56	2.63	2.50	0.22 x 0.44	4.37	5.13	2.80	PFK1	FG2*/FGF2
100	PH100AJ	A	0.83/0.42	3.25	4.06	3.63	2.63	2.63	0.22 x 0.44	4.44	5.50	4.10	PFK1	FG2*/FGF2
150	PH150AJ	B	1.25/0.63	4.00	4.63	3.81	3.38	2.75	0.22 x 0.75	4.50	6.13	4.90	PFK2	FG3
250	PH250AJ	B	2.08/1.04	4.50	5.25	3.81	3.75	3.13	0.22 x 0.75	4.50	6.75	6.97	PFK2	FG3
350	PH350AJ	B	2.92/1.46	4.50	4.88	4.44	3.75	3.75	0.22 x 0.75	4.94	6.38	8.30	PFK3	FG4
500	PH500AJ	B	4.17/2.08	4.75	5.56	4.31	4.06	3.44	0.31 x 0.94	4.81	7.06	11.6	PFK3	FG4
750	PH750AJ	B	6.25/3.13	5.13	6.38	4.31	4.38	4.00	0.31 x 0.81	4.81	7.88	16.6	PFK3	FG4
1000	PH1000AJ	B	8.33/4.17	5.25	6.50	4.94	4.50	4.09	0.31 x 0.81	5.56	8.00	21.0	PFK3	FG5
1500	PH1500AJ	B	12.5/6.25	5.25	7.56	4.94	4.50	5.44	0.38 x 1.00	5.56	9.06	30.0	PFK3	FG5

Secondary fuse clips, fuse clip mounting screws and primary and secondary voltage links/jumpers supplied standard with transformers. All dimensions in inches
 *Note: Unfused finger guard kits are marked with an asterisk, for more information refer to page 45.
 Refer to page 64 for wiring schematic drawing. Custom voltage and VA sizes available upon request.

Group B

Primary Voltage: **600** || **575** || **550**  **60 Hertz**
 Secondary Voltage: **12 X 24** || **11.5 X 23** || **11 X 22**

VA Rating	Catalog Number	Mtg. Fig.	Output Amps	Overall Dimensions			Mounting Centers		Mounting Slot	Height with Finger Guard	Depth with Finger Guard	Approx. Ship Weight Lbs.	Optional Primary Fuse Kit P/N	Optional Unfused and Fused Finger Guard Kit P/N
				A	B	C	D	E	G X H					
50	PH50AR	A	4.17/2.08	3.00	3.81	3.19	2.50	2.25	0.22 x 0.44	4.00	5.25	2.70	PFK1	FG1*/FGF1
75	PH75AR	A	6.25/3.13	3.25	3.69	3.56	2.63	2.50	0.22 x 0.44	4.37	5.13	2.80	PFK1	FG2*/FGF2
100	PH100AR	A	8.33/4.17	3.25	4.19	3.63	2.63	2.63	0.22 x 0.44	4.44	5.63	4.50	PFK1	FG2*/FGF2
150	PH150AR	B	12.5/6.25	4.00	4.94	3.81	3.38	2.75	0.22 x 0.75	4.50	6.44	5.70	PFK2	FG3
250	PH250AR	B	20.8/10.4	4.50	5.44	3.81	3.75	3.13	0.22 x 0.75	4.50	6.94	7.50	PFK2	FG3
350	PH350AR	B	29.2/14.6	4.50	4.88	4.44	3.75	3.75	0.22 x 0.75	4.94	6.38	8.30	PFK3	FG4
500	PH500AR	B	41.7/20.8	4.75	5.56	4.31	4.06	3.44	0.31 x 0.94	4.81	7.06	11.6	PFK3	FG4

Secondary fuse clips, fuse clip mounting screws and primary and secondary voltage links/jumpers supplied with transformers. All dimensions in inches
 *Note: Unfused finger guard kits are marked with an asterisk, for more information refer to page 45.
 Refer to page 65 for wiring schematic drawing. Custom voltages and VA sizes available upon request.

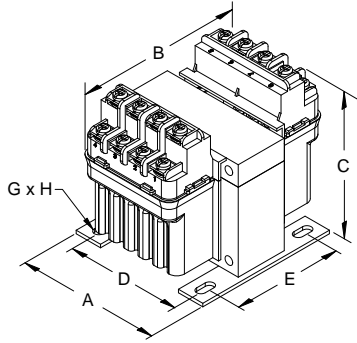

FIGURE A

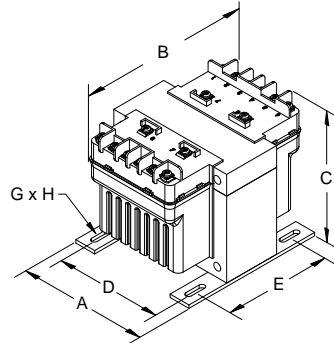

FIGURE B

Group C

Primary Voltage: 240 X 480 || 230 X 460 || 220 X 440
 Secondary Voltage: 120 X 240 || 115 X 230 || 110 X 220

50/60 Hertz

VA Rating	Catalog Number	Mtg. Fig.	Output Amps	Overall Dimensions			Mounting Centers		Mounting Slot G X H	Height with Finger Guard	Depth with Finger Guard	Approx. Ship Weight Lbs.	Optional Primary Fuse Kit P/N	Optional Unfused and Fused Finger Guard Kit P/N
				A	B	C	D	E						
50	PH50MQMJ	A	0.42/0.21	3.00	4.38	3.19	2.50	2.25	0.22 x 0.44	4.00	5.82	3.50	PFK1	FG1*/FGF1
75	PH75MQMJ	A	0.63/0.31	3.25	3.88	3.56	2.63	2.50	0.22 x 0.44	4.37	5.32	3.54	PFK1	FG2*/FGF2
100	PH100MQMJ	A	0.83/0.42	3.25	4.19	3.63	2.63	2.63	0.22 x 0.44	4.44	5.63	4.50	PFK1	FG2*/FGF2
150	PH150MQMJ	B	1.25/0.63	4.00	4.94	3.81	3.38	2.75	0.22 x 0.75	4.50	6.44	5.70	PFK2	FG3
250	PH250MQMJ	B	2.08/1.04	4.50	5.44	3.81	3.75	3.13	0.22 x 0.75	4.50	6.94	7.50	PFK2	FG3
350	PH350MQMJ	B	2.92/1.46	4.50	5.19	4.44	3.75	3.75	0.22 x 0.75	4.94	6.69	10.1	PFK3	FG4
500	PH500MQMJ	B	4.17/2.08	4.75	5.94	4.31	4.06	3.81	0.31 x 0.94	4.81	7.44	14.2	PFK3	FG4
750	PH750MQMJ	B	6.25/3.13	5.13	6.69	4.31	4.38	4.31	0.31 x 0.81	4.81	8.19	16.6	PFK3	FG4
1000	PH1000MQMJ	B	8.33/4.17	5.25	6.81	4.94	4.50	4.44	0.31 x 0.81	5.56	8.31	23.6	PFK3	FG5
1500	PH1500MQMJ	B	12.5/6.25	5.25	8.19	4.94	4.50	6.06	0.38 x 1.00	5.56	9.69	32.0	PFK3	FG5

Secondary fuse clips, fuse clip mounting screws and primary and secondary voltage links/jumpers supplied standard with transformers. All dimensions in inches
 *Note: Unfused finger guard kits are marked with an asterisk, for more information refer to page 45.
 Refer to page 66 for wiring schematic drawing. Custom voltages and VA sizes available upon request.
 *** Available with FACTORY INSTALLED Primary and Secondary Fuse Kits up to 1500VA. To order, add the suffix "-FK" to the above part number. Refer to page 44 for details. ***

Group D

Primary Voltage: 240 X 480 || 230 X 460 || 220 X 440
 Secondary Voltage: 12 X 24 || 11.5 X 23 || 11 X 22

50/60 Hertz

VA Rating	Catalog Number	Mtg. Fig.	Output Amps	Overall Dimensions			Mounting Centers		Mounting Slot G X H	Height with Finger Guard	Depth with Finger Guard	Approx. Ship Weight Lbs.	Optional Primary Fuse Kit P/N	Optional Unfused and Fused Finger Guard Kit P/N
				A	B	C	D	E						
50	PH50QR	A	4.17/2.08	3.00	4.38	3.19	2.50	2.25	0.22 x 0.44	4.00	5.82	3.50	PFK1	FG1*/FGF1
75	PH75QR	A	6.25/3.13	3.25	3.88	3.56	2.63	2.50	0.22 x 0.44	4.37	5.32	3.54	PFK1	FG2*/FGF2
100	PH100QR	A	8.33/4.17	3.25	4.19	3.63	2.63	2.63	0.22 x 0.44	4.44	5.63	4.50	PFK1	FG2*/FGF2
150	PH150QR	B	12.5/6.25	4.00	4.94	3.81	3.38	2.75	0.22 x 0.75	4.50	6.44	5.70	PFK2	FG3
250	PH250QR	B	20.8/10.4	4.50	5.44	3.81	3.75	3.13	0.22 x 0.75	4.50	6.94	7.50	PFK2	FG3
350	PH350QR	B	29.2/14.6	4.50	5.19	4.44	3.75	3.75	0.22 x 0.75	4.94	6.69	10.1	PFK3	FG4
500	PH500QR	B	41.7/20.8	4.75	5.94	4.31	4.06	3.81	0.31 x 0.94	4.81	7.44	14.2	PFK3	FG4

Secondary fuse clips, fuse clip mounting screws and primary and secondary voltage links/jumpers supplied standard with transformers. All dimensions in inches
 *Note: Unfused finger guard kits are marked with an asterisk, for more information refer to page 45.
 Refer to page 67 for wiring schematic drawing. Custom voltages and VA sizes available upon request.

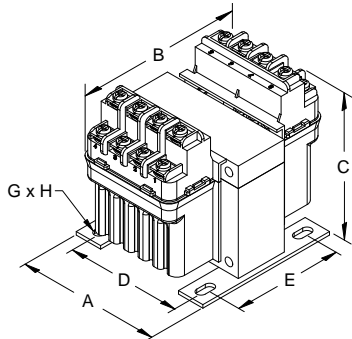

FIGURE A

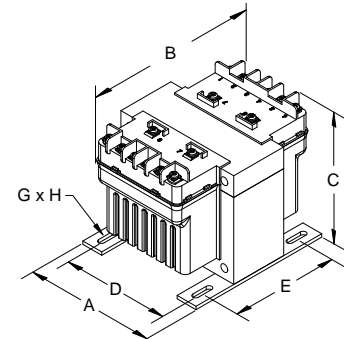

FIGURE B

Group E

Primary Voltage: 208 X 416 || 200 X 400 || 190 X 380
 Secondary Voltage: 120 X 240 || 115 X 230 || 110 X 220

  50/60 Hertz

VA Rating	Catalog Number	Mtg. Fig.	Output Amps	Overall Dimensions			Mounting Centers		Mounting Slot G X H	Height with Finger Guard	Depth with Finger Guard	Approx. Ship Weight Lbs.	Optional Primary Fuse Kit P/N	Optional Unfused and Fused Finger Guard Kit P/N
				A	B	C	D	E						
50	PH50SP	A	0.42/0.21	3.00	4.38	3.19	2.50	2.25	0.22 x 0.44	4.00	5.82	3.50	PFK1	FG1*/FGF1
75	PH75SP	A	0.63/0.31	3.25	3.88	3.56	2.63	2.50	0.22 x 0.44	4.37	5.32	3.54	PFK1	FG2*/FGF2
100	PH100SP	A	0.83/0.42	3.25	4.19	3.63	2.63	2.63	0.22 x 0.44	4.44	5.63	4.50	PFK1	FG2*/FGF2
150	PH150SP	B	1.25/0.63	4.00	4.94	3.81	3.38	2.75	0.22 x 0.75	4.50	6.44	5.70	PFK2	FG3
250	PH250SP	B	2.08/1.04	4.50	5.44	3.81	3.75	3.13	0.22 x 0.75	4.50	6.94	7.50	PFK2	FG3
350	PH350SP	B	2.92/1.46	4.50	5.19	4.44	3.75	3.75	0.22 x 0.75	4.94	6.69	10.1	PFK3	FG4
500	PH500SP	B	4.17/2.08	4.75	5.94	4.31	4.06	3.81	0.31 x 0.94	4.81	7.44	14.2	PFK3	FG4
750	PH750SP	B	6.25/3.13	5.13	6.69	4.31	4.38	4.31	0.31 x 0.81	4.81	8.19	16.6	PFK3	FG4
1000	PH1000SP	B	8.33/4.17	5.25	6.81	4.94	4.50	4.44	0.31 x 0.81	5.56	8.31	23.6	PFK3	FG5

Secondary fuse clips, fuse clip mounting screws and primary and secondary voltage links/jumpers supplied standard with transformers. All dimensions in inches
 *Note: Unfused finger guard kits are marked with an asterisk, for more information refer to page 45.
 Refer to page 68 for wiring schematic drawing. Custom voltages and VA sizes available upon request.

Group F

Primary Voltage: 120 X 240 || 115 X 230 || 110 X 220
 Secondary Voltage: 120 X 240 || 115 X 230 || 110 X 220

  50/60 Hertz

VA Rating	Catalog Number	Mtg. Fig.	Output Amps	Overall Dimensions			Mounting Centers		Mounting Slot G X H	Height with Finger Guard	Depth with Finger Guard	Approx. Ship Weight Lbs.	Optional Primary Fuse Kit P/N	Optional Unfused and Fused Finger Guard Kit P/N
				A	B	C	D	E						
50	PH50PP	A	0.42/0.21	3.00	4.38	3.19	2.50	2.25	0.22 x 0.44	4.00	5.82	3.50	PFK1	FG1*/FGF1
75	PH75PP	A	0.63/0.31	3.25	3.88	3.56	2.63	2.50	0.22 x 0.44	4.37	5.32	3.54	PFK1	FG2*/FGF2
100	PH100PP	A	0.83/0.42	3.25	4.19	3.63	2.63	2.63	0.22 x 0.44	4.44	5.63	4.50	PFK1	FG2*/FGF2
150	PH150PP	B	1.25/0.63	4.00	4.94	3.81	3.38	2.75	0.22 x 0.75	4.50	6.44	5.70	PFK2	FG3
250	PH250PP	B	2.08/1.04	4.50	5.44	3.81	3.75	3.13	0.22 x 0.75	4.50	6.94	7.50	PFK2	FG3
350	PH350PP	B	2.92/1.46	4.50	5.19	4.44	3.75	3.75	0.22 x 0.75	4.94	6.69	10.1	PFK3	FG4
500	PH500PP	B	4.17/2.08	4.75	5.94	4.31	4.06	3.81	0.31 x 0.94	4.81	7.44	14.2	PFK3	FG4
750	PH750PP	B	6.25/3.13	5.13	6.69	4.31	4.38	4.31	0.31 x 0.81	4.81	8.19	16.6	PFK3	FG4
1000	PH1000PP	B	8.33/4.17	5.25	6.81	4.94	4.50	4.44	0.31 x 0.81	5.56	8.31	23.6	PFK3	FG5
1500	PH1500PP	B	12.5/6.25	5.25	8.19	4.94	4.50	6.06	0.38 x 1.0	5.56	9.69	32.0	PFK3	FG5

Secondary fuse clips, fuse clip mounting screws and primary and secondary voltage links/jumpers supplied standard with transformers. All dimensions in inches
 *Note: Unfused finger guard kits are marked with an asterisk, for more information refer to page 45.
 Refer to page 69 for wiring schematic drawing. Custom voltages and VA sizes available upon request.



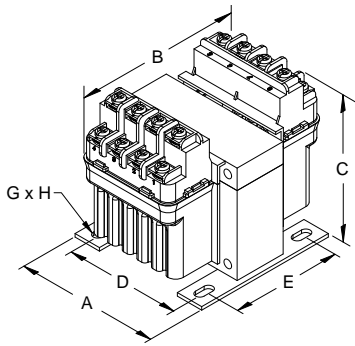

FIGURE A

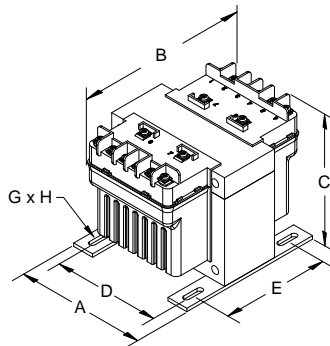

FIGURE B

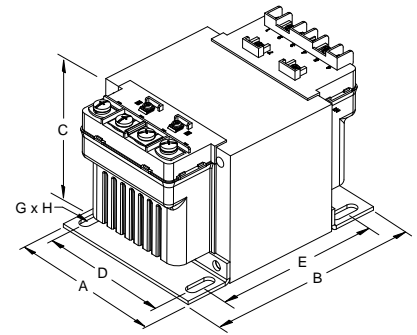

FIGURE C

Group G

Primary Voltage: 120 X 240 || 115 X 230 || 110 X 220
 Secondary Voltage: 12 X 24 || 11.5 X 23 || 11 X 22

50/60 Hertz

VA Rating	Catalog Number	Mtg. Fig.	Output Amps	Overall Dimensions			Mounting Centers		Mounting Slot G X H	Height with Finger Guard	Depth with Finger Guard	Approx. Ship Weight Lbs.	Optional Primary Fuse Kit P/N	Optional Unfused and Fused Finger Guard Kit P/N
				A	B	C	D	E						
50	PH50PG	A	4.17/2.08	3.00	4.38	3.19	2.50	2.25	0.22 x 0.44	4.00	5.82	3.50	PFK1	FG1*/FGF1
75	PH75PG	A	6.25/3.13	3.25	3.88	3.56	2.63	2.50	0.22 x 0.44	4.37	5.32	3.54	PFK1	FG2*/FGF2
100	PH100PG	A	8.33/4.17	3.25	4.19	3.63	2.63	2.63	0.22 x 0.44	4.44	5.63	4.50	PFK1	FG2*/FGF2
150	PH150PG	B	12.5/6.25	4.00	4.94	3.81	3.38	2.75	0.22 x 0.75	4.50	6.44	5.70	PFK2	FG3
250	PH250PG	B	20.8/10.4	4.50	5.44	3.81	3.75	3.13	0.22 x 0.75	4.50	6.94	7.50	PFK2	FG3
350	PH350PG	B	29.2/14.6	4.50	5.19	4.44	3.75	3.75	0.22 x 0.75	4.94	6.69	10.1	PFK3	FG4
500	PH500PG	B	41.7/20.8	4.75	5.94	4.31	4.06	3.81	0.31 x 0.94	4.81	7.44	14.2	PFK3	FG4
750	PH750PG	C	62.5/31.3	5.13	6.69	4.31	4.38	4.31	0.31 x 0.81	4.81	8.19	16.6	PFK3	FG5
1000	PH1000PG	C	83.3/41.7	5.25	6.81	4.94	4.50	4.44	0.31 x 0.81	5.56	8.31	23.6	PFK3	FG5

Secondary fuse clips and fuse clip mounting screws supplied standard with transformers up to and including 500VA. Primary and Secondary voltage links/jumpers supplied standard with transformers. All dimensions in inches

*Note: Unfused finger guard Kits are marked with an asterisk, for more information refer to page 45.

Refer to page 70 for wiring schematic drawing. Custom voltages and VA sizes available upon request.

*** Available with FACTORY INSTALLED Primary and Secondary Fuse Kits up to 1500VA. To order, add the suffix "-FK" to the above part number. Refer to page 44 for details. ***

Group H

Primary Voltage: 600/480/240 || 575/460/230 || 550/440/220
 Secondary Voltage: 120/100 || 115/95 || 110/90

50/60 Hertz

VA Rating	Catalog Number	Mtg. Fig.	Output Amps	Overall Dimensions			Mounting Centers		Mounting Slot G X H	Height with Finger Guard	Depth with Finger Guard	Approx. Ship Weight Lbs.	Optional Primary Fuse Kit P/N	Optional Unfused and Fused Finger Guard Kit P/N
				A	B	C	D	E						
50	PH50MBMH	A	0.43	3.25	4.06	3.63	2.63	2.63	0.22 x 0.44	4.44	5.50	4.10	PFK4	FG2*/FGF2
75	PH75MBMH	A	0.65	3.25	4.19	3.63	2.63	2.63	0.22 x 0.44	4.44	5.63	4.50	PFK5	FG2*/FGF2
100	PH100MBMH	B	0.87	4.00	4.63	3.81	3.38	2.75	0.22 x 0.75	4.50	6.13	4.90	PFK6	FG3
150	PH150MBMH	B	1.30	4.00	5.44	3.81	3.38	2.75	0.22 x 0.75	4.50	6.94	7.60	PFK6	FG3
250	PH250MBMH	B	2.17	4.50	5.19	4.44	3.75	3.75	0.22 x 0.75	4.94	6.69	10.1	PFK6	FG4
350	PH350MBMH	B	3.04	4.50	5.56	4.44	3.75	3.75	0.22 x 0.75	4.94	7.06	11.0	PFK7	FG4
500	PH500MBMH	B	4.35	4.75	6.69	4.31	4.06	4.50	0.31 x 0.94	4.81	8.19	16.3	PFK7	FG4
750	PH750MBMH	B	6.52	5.25	6.81	4.94	4.50	4.44	0.31 x 0.81	5.56	8.31	23.6	PFK7	FG5
1000	PH1000MBMH	B	8.70	5.25	8.19	4.94	4.50	5.81	0.31 x 0.81	5.56	9.69	31.2	PFK7	FG5
1500	PH1500MBMH	B	13.0	5.25	8.19	4.94	4.50	6.06	0.38 x 1.0	5.56	9.69	32.0	PFK7	FG5

Secondary fuse clips, fuse clip mounting screws and primary and secondary voltage links/jumpers supplied standard with transformers. All dimensions in inches

*Note: Unfused finger guard kits are marked with an asterisk, for more information refer to page 45.

Refer to page 71 for wiring schematic drawing. Custom voltage and VA sizes available upon request.

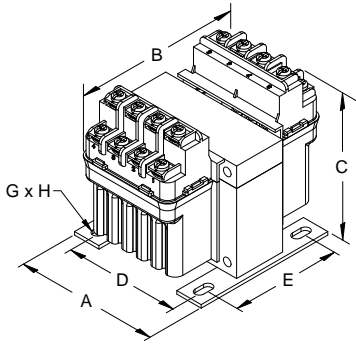

FIGURE A

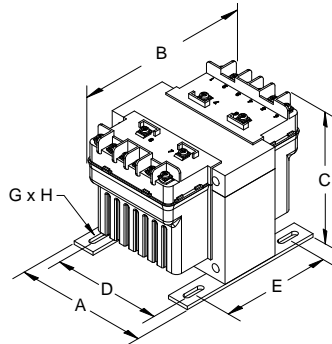

FIGURE B

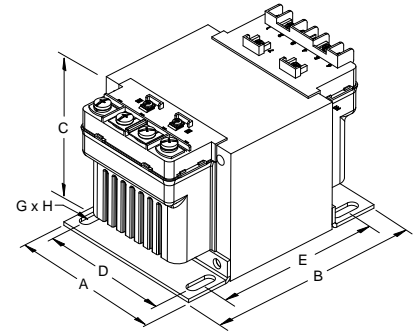

FIGURE C

Group I

Primary Voltage: 480/240 || **460/230/208** || 440/220/200
 Secondary Voltage: 120/25 || **115/24** || 110/23

cUL[®] US CE 50/60 Hertz

VA Rating	Catalog Number	Mtg. Fig.	Output Amps	Overall Dimensions			Mounting Centers		Mounting Slot G X H	Height with Finger Guard	Depth with Finger Guard	Approx. Ship Weight Lbs.	Optional Primary Fuse Kit P/N	Optional Unfused and Fused Finger Guard Kit P/N
				A	B	C	D	E						
50	PH50MLI	A	0.43/2.08	3.25	4.06	3.56	2.63	2.50	0.22 x 0.44	4.37	5.50	4.00	PFK5	FG2*/FGF2
75	PH75MLI	A	0.65/3.13	3.25	4.25	3.56	2.63	2.50	0.22 x 0.44	4.37	5.69	4.60	PFK5	FG2*/FGF2
100	PH100MLI	A	0.87/4.17	3.25	4.69	3.63	2.63	2.63	0.22 x 0.44	4.44	6.13	5.20	PFK5	FG2*/FGF2
150	PH150MLI	B	1.30/6.25	4.00	5.44	3.81	3.38	2.75	0.22 x 0.75	4.50	6.94	7.60	PFK6	FG3
250	PH250MLI	B	2.17/10.42	4.50	5.19	4.44	3.75	3.75	0.22 x 0.75	4.94	6.69	10.1	PFK6	FG4
350	PH350MLI	B	3.04/14.58	4.50	5.56	4.44	3.75	3.75	0.22 x 0.75	4.94	7.06	11.0	PFK7	FG4
500	PH500MLI	B	4.35/20.83	4.75	6.69	4.31	4.06	4.50	0.31 x 0.94	4.81	8.19	16.3	PFK7	FG4
750	PH750MLI	C	6.52/31.25	5.25	6.50	4.94	4.50	4.13	0.31 x 0.81	5.56	8.00	21.0	PFK7	FG5
1000	PH1000MLI	C	8.70/41.67	5.25	8.19	4.94	4.50	5.81	0.31 x 0.81	5.56	9.69	31.2	PFK7	FG5

Secondary fuse clips and fuse clip mounting screws supplied standard with transformers up to and including 500VA. All dimensions in inches
 Primary and Secondary voltage links/jumpers supplied standard with transformers up to and including 1000VA.
 *Note: Unfused finger guard kits are marked with an asterisk, for more information refer to page 45.
 Refer to page 72 for wiring schematic drawing. Custom voltages and VA sizes available upon request.
 *** Available with FACTORY INSTALLED Primary and Secondary Fuse Kits up to 1500VA. To order, add the suffix "-FK" to the above part number. Refer to page 44 for details. ***

Group J

Primary Voltage: 415/400/380
 Secondary Voltage: 110 X 220

cUL[®] US CE 50/60 Hertz

VA Rating	Catalog Number	Mtg. Fig.	Output Amps	Overall Dimensions			Mounting Centers		Mounting Slot G X H	Height with Finger Guard	Depth with Finger Guard	Approx. Ship Weight Lbs.	Optional Primary Fuse Kit P/N	Optional Unfused and Fused Finger Guard Kit P/N
				A	B	C	D	E						
50	PH50MEMX	A	0.45/0.23	3.00	4.38	3.19	2.50	2.25	0.22 x 0.44	4.00	5.82	3.50	PFK4	FG1*/FGF1
75	PH75MEMX	A	0.68/0.34	3.25	4.06	3.63	2.63	2.63	0.22 x 0.44	4.44	5.50	4.10	PFK5	FG2*/FGF2
100	PH100MEMX	A	0.91/0.45	3.25	4.19	3.63	2.63	2.63	0.22 x 0.44	4.44	5.63	4.50	PFK5	FG2*/FGF2
150	PH150MEMX	B	1.36/0.68	4.00	4.94	3.81	3.38	2.75	0.22 x 0.75	4.50	6.44	5.70	PFK6	FG3
250	PH250MEMX	B	2.27/1.14	4.50	5.44	3.81	3.75	3.13	0.22 x 0.75	4.50	6.94	7.50	PFK6	FG3
350	PH350MEMX	B	3.18/1.59	4.50	5.19	4.44	3.75	3.75	0.22 x 0.75	4.94	6.69	10.1	PFK7	FG4
500	PH500MEMX	B	4.55/2.27	4.75	5.94	4.31	4.06	3.81	0.31 x 0.94	4.81	7.44	14.2	PFK7	FG4
750	PH750MEMX	B	6.82/3.41	5.25	6.50	4.94	4.50	4.13	0.31 x 0.81	5.56	8.00	21.0	PFK7	FG5
1000	PH1000MEMX	B	9.09/4.55	5.25	6.81	4.94	4.50	4.44	0.31 x 0.81	5.56	8.31	23.6	PFK7	FG5

Secondary fuse clips, fuse clip mounting screws and primary and secondary voltage links/jumpers supplied standard with transformers. All dimensions in inches
 *Note: Unfused finger guard kits are marked with an asterisk, for more information refer to page 45.
 Refer to page 73 for wiring schematic drawing. Custom voltages and VA sizes available upon request.



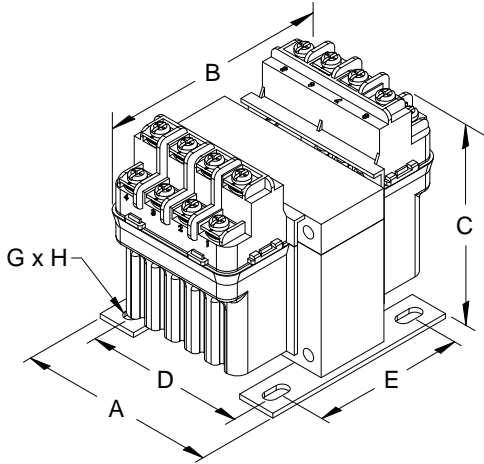

FIGURE A

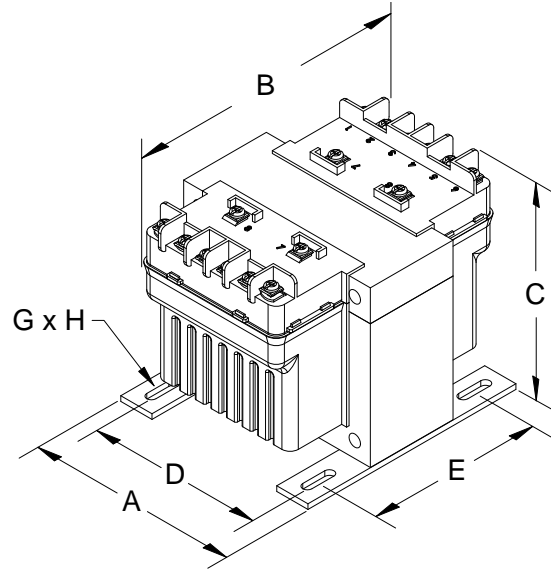

FIGURE B

Group K

Primary Voltage: 380/277/208

Secondary Voltage: 120 X 240



50/60 Hertz

VA Rating	Catalog Number	Mtg. Fig.	Output Amps	Overall Dimensions			Mounting Centers		Mounting Slot G X H	Height with Finger Guard	Depth with Finger Guard	Approx. Ship Weight Lbs.	Optional Primary Fuse Kit P/N	Optional Unfused and Fused Finger Guard Kit P/N
				A	B	C	D	E						
50	PH50MGJ	A	0.42/0.21	3.25	3.88	3.56	2.63	2.50	0.22 x 0.44	4.37	5.32	3.54	PFK4	FG2*/FGF2
75	PH75MGJ	A	0.63/0.31	3.25	4.19	3.63	2.63	2.63	0.22 x 0.44	4.44	5.63	4.50	PFK5	FG2*/FGF2
100	PH100MGJ	A	0.83/0.42	3.25	4.69	3.63	2.63	2.63	0.22 x 0.44	4.44	6.13	5.20	PFK5	FG2*/FGF2
150	PH150MGJ	B	1.25/0.63	4.00	5.44	3.81	3.38	2.75	0.22 x 0.75	4.50	6.94	7.60	PFK6	FG3
250	PH250MGJ	B	2.08/1.04	4.50	4.88	4.44	3.75	3.75	0.22 x 0.75	4.94	6.38	8.30	PFK6	FG4
350	PH350MGJ	B	2.92/1.46	4.50	5.56	4.44	3.75	3.75	0.22 x 0.75	4.94	7.06	11.0	PFK7	FG4
500	PH500MGJ	B	4.17/2.08	4.75	6.69	4.31	4.06	4.50	0.31 x 0.94	4.81	8.19	16.3	PFK7	FG4
750	PH750MGJ	B	6.25/3.13	5.25	6.81	4.94	4.50	4.44	0.31 x 0.81	5.56	8.31	23.6	PFK7	FG5
1000	PH1000MGJ	B	8.33/4.17	5.25	7.25	4.94	4.50	4.83	0.31 x 0.81	5.44	8.75	25.5	PFK7	FG5

Secondary fuse clips, fuse clip mounting screws and primary and secondary voltage links/jumpers supplied standard with transformers.

All dimensions in inches

*Note: Unfused finger guard kits are marked with an asterisk, for more information refer to page 45.
Refer to page 74 for wiring schematic drawings. Custom voltages and VA sizes available upon request.



Field Installed Fuse Kits

Standard Secondary Fuse Kits (Field Installed)

All HPS Imperator control transformers are supplied with standard secondary fuse kits which include: 13/32" x 1 1/2" midget/type CC fuse clips, fuse clip mounting screws, primary and secondary voltage links and the PHAK1 instruction sheet (note: secondary fuse clips and fuse clip mounting screws are not supplied on the PH750PG, PH1000PG, PH750MLI, and PH1000MLI).

Optional Primary Fuse Kits (Field Installed)

All HPS Imperator series machine tool industrial control transformers up to and including 1500VA are available with the following optional primary fuse kits:

Kit Part Number	Applicable Transformer Part Number Suffix's	Applicable VA Sizes	Parts Included in Kit
PFK1	<p>Refer to Specification Tables on Pages 38 to 43 for Optional Primary Fuse Kit P/N</p>	<p>Refer to Specification Tables on Pages 38 to 43 for Optional Primary Fuse Kit P/N</p>	4 fuse clips, 4 mtg. screws, PHAK1 instruction sheet
PFK2			4 fuse clips, 4 mtg. screws, PHAK1 instruction sheet
PFK3			4 fuse clips, 4 mtg. screws, PHAK1 instruction sheet
PFK4			4 fuse clips, 4 mtg. screws, 1 jumper, 1 finger guard, PHAK1 instruction sheet
PFK5			4 fuse clips, 4 mtg. screws, 1 jumper, 1 finger guard, PHAK1 instruction sheet
PFK5			4 fuse clips, 4 mtg. screws, 1 jumper, 1 finger guard, PHAK1 instruction sheet
PFK6			4 fuse clips, 4 mtg. screws, 1 jumper wire, PHAK1 instruction sheet
PFK6	4 fuse clips, 4 mtg. screws, 1 jumper wire, PHAK1 instruction sheet		
PFK7	4 fuse clips, 4 mtg. screws, 1 jumper wire, PHAK1 instruction sheet		

Note: Maximum allowable current rating on all primary and secondary fuse kits is 30 amps.

Factory Installed Fuse Kits

Factory Installed Primary and Secondary Fuse Kits

HPS now stocks some HPS Imperator series voltage groups with FACTORY INSTALLED primary and secondary fuse clips. To order, just add the suffix "-FK" to the end of the standard part number.

Factory installed fusing only available on units up to 1500VA. The voltage groups that are stocked are:

Group C (p/n: PH*MQMJ-FK) | Group G (p/n: PH***PG-FK) | Group I (p/n: PH***MLI-FK)**

On PH750PG-FK, PH1000PG-FK, PH750MLI-FK, and PH1000MLI-FK, only primary fuse clips are included on factory installed units. Secondary fuse clips are not included or available on these units.

Other voltage groups available with factory installed fuse kits. Please contact your HPS sales or customer service representative for details.

Note: All factory installed fuse kits are pre-wired at the transformers highest primary voltage and the lowest secondary voltage. To hook up at a different primary or secondary voltage, please refer to the wiring instruction sheet included with the transformer.

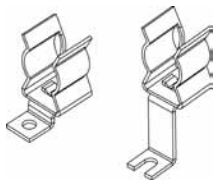

Sample Accessory Drawing for Fuse Clips
(for 50, 75 and 100VA)

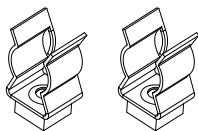

Sample Accessory Drawing for Fuse Clips
(for 150VA to 1500VA)

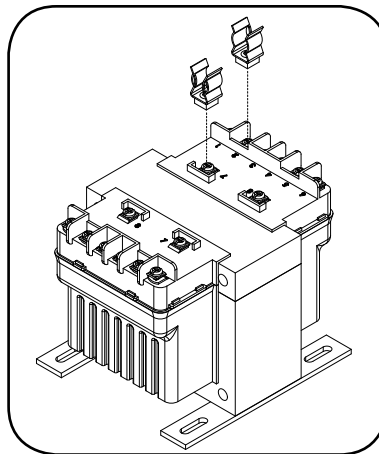

Sample Assembly Drawing for Secondary Fuse Clip Installation
(For 150VA to 1500VA)

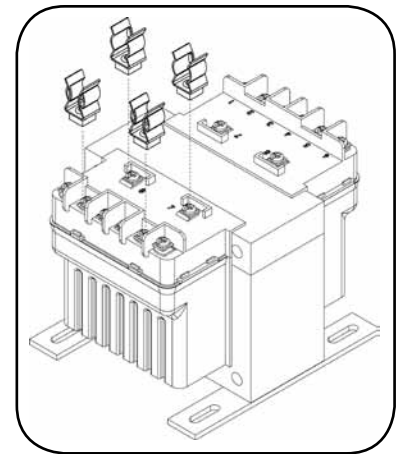

Sample Assembly Drawing for Primary Fuse Clip Installation
(For 150VA to 1500VA)

Note: HPS Imperator primary and secondary fuse kits are not suitable for *branch circuit* applications!

Optional Accessories

Finger Guards

The HPS Imperator line of machine tool industrial molded control transformers are available with the following optional finger guard kits:

Optional Unfused Finger Guard Kits

Kit Part Number	Applicable Transformer Part Number Suffixes	Applicable VA Sizes
FG1	AJ, AR, MQMJ, MEMX, QR, SP, PG, PP	50
FG2	MBMH, MGJ, MLI	50
FG2	All	75
FG2	All (excluding PH100MBMH) <i>Refer to FG3, FG4 or FG5 below</i>	100 150 to 1500

Note: Each finger guard kit supplies either the primary or secondary side.
Included in the kit: 1 finger guard (unfused) and PHAK1 instruction sheet

Optional Fused Finger Guard Kits

Kit Part Number	Applicable Transformer Part Number Suffixes	Applicable VA Sizes	Parts Included in Kit
FGF1	AJ, AR, MQMJ, MEMX, QR, SP, PG, PP	50	1 finger guard (fused), PHAK1 instruction sheet
FGF2	MBMH, MGJ, MLI	50	1 finger guard (fused), PHAK1 instruction sheet
FGF2	All	75	1 finger guard (fused), PHAK1 instruction sheet
FGF2	All (excluding PH100MBMH)	100	1 finger guard (fused), PHAK1 instruction sheet
FG3	MBMH	100	1 finger guard, PHAK1 instruction sheet
FG3	All	150	1 finger guard, PHAK1 instruction sheet
FG3	AJ, AR, MQMJ, MEMX, QR, SP, PG, PP	250	1 finger guard, PHAK1 instruction sheet
FG4	MBMH, MGJ, MLI	250	1 finger guard, PHAK1 instruction sheet
FG4	All	350, 500	1 finger guard, PHAK1 instruction sheet
FG4	AJ, AR, MQMJ, QR, SP, PP	750	1 finger guard, PHAK1 instruction sheet
FG5	MBMH, MEMX, MGJ, MLI, PG	750	1 finger guard, PHAK1 instruction sheet
FG5	All	1000, 1500	1 finger guard, PHAK1 instruction sheet

Note: Each finger guard kit supplies either the primary or secondary side.

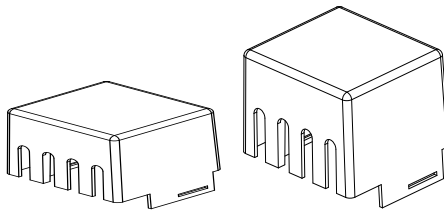

**Sample Accessory Drawing
for Fused & Unfused
Finger Guards**
(for 50, 75 and 100VA)

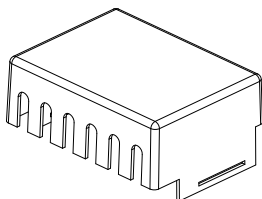

**Sample Accessory Drawing
for Finger Guards**
(for 150VA and 1500VA)

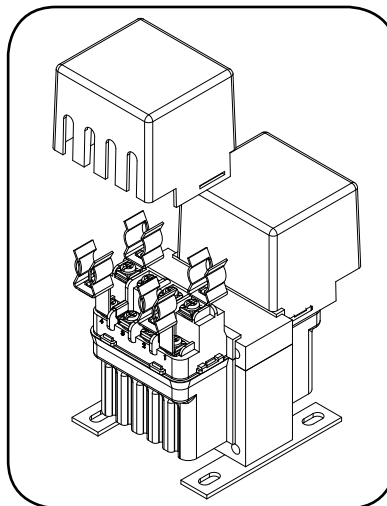

**Sample Assembly Drawing
for Finger Guard Installation**
(For 50, 75 and 100VA)

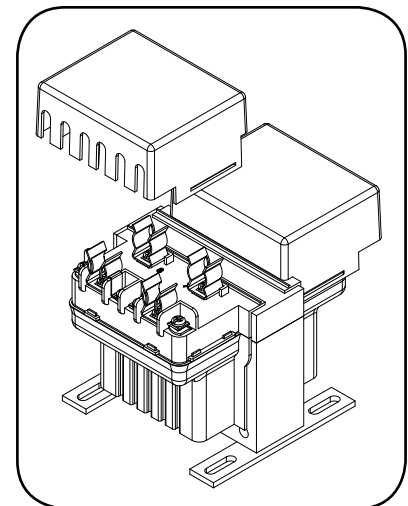

**Sample Assembly Drawing
for Finger Guard Installation**
(For 150VA to 1500VA)

HPS Spartan® Industrial Open-Style Control Transformer

SECTION 1

The Economical Solution

The HPS Spartan® line of industrial control transformers are ideally suited for general purpose, industrial and light duty loads. Designed for applications where high inrush or machine tool duty are not necessary, the HPS Spartan industrial open-style control transformer offers an efficient and economical solution. These units are well suited for HVAC applications, signal and alarm systems, motor control circuits, lighting and circuit isolation.

The HPS Spartan control transformer is an open style unit with molded terminal blocks up to 3000 VA or 30 amps. Optional Finger guards and a fuse block adapter kit are available upon request.

For an economical approach to control transformers, the HPS Spartan is the transformer of choice.



STANDARDS		
The HPS Spartan Control Transformers meet or exceed the standards established by UL, CSA, IEC and NEMA.		
Standard	File #	VA Size
UL (ANSI/UL506)	E50394	All
CSA	LR3902	All
IEC 61558		All
NEMA (ST-1)		All



Features and Benefits

- Molded terminal blocks for primary and secondary connections¹
- Coil face termination over 3000VA or 30 amps
- Vacuum Impregnated with Polyester Resin and oven cured
- Bolted core construction
- Bolt-on mounting brackets
- All terminal blocks utilize a combination slot/Phillips #6 screw with a SEMS washer (suitable for 18 AWG to 14 AWG for solid wire and 18 AWG to 12 AWG for stranded wire). Coil face terminations utilize a ¼ - 20 UNC X 0.50" combination slot/Phillips screw and a spring lock washer
- All units supplied with primary and secondary voltage links/jumpers
- 50/60 Hz (60 Hz on SP***ACP and SP***AR)
- Copper wound coils with high dielectric strength insulation
- Seismically certified in accordance with 2009 IBC for $S_{DS} \leq 2.00g$, $z/h = 1.0$ and $I_p = 1.5$
- CSA Certified, UL Listed, CE Marked and RoHS compliant
- Meets NEMA standards
- Superior insulating materials. The HPS Spartan series transformers offer the following insulation systems:

Up to 1500 VA:	80°C rise, 130°C temperature class (B)
2000 VA to 5000 VA:	115°C rise, 180°C temperature class (F)
- "Premium Packaging"¹ which feature:
 - Premium fluted cartons
 - Custom molded foam inserts
 - Easy removal and repacking
 - Industry's best box label
- Supplied with trilingual installation and wiring instruction sheets
- 15 year warranty
- Optional finger guards available¹
- Optional fuse block adapter kit available¹

¹ up to and including 3000VA or 30 amps

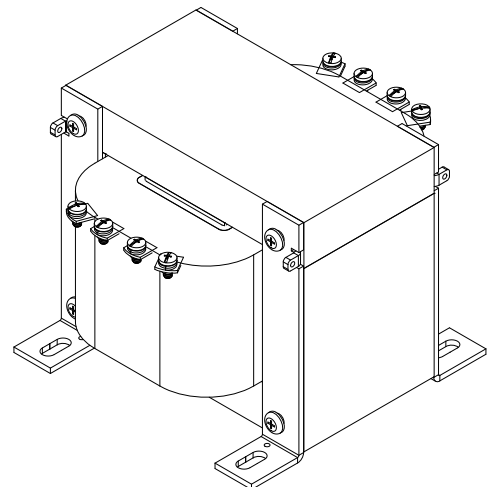
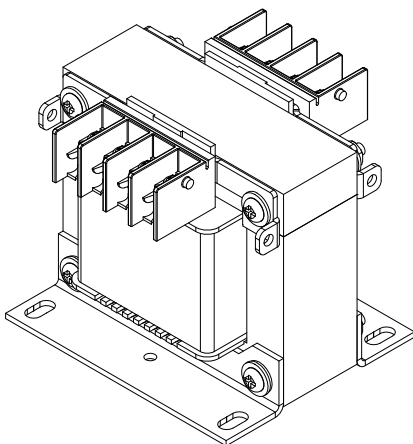

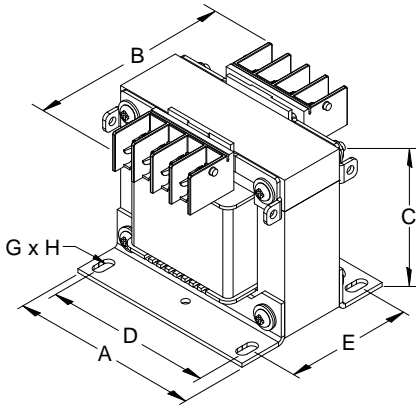

FIGURE A

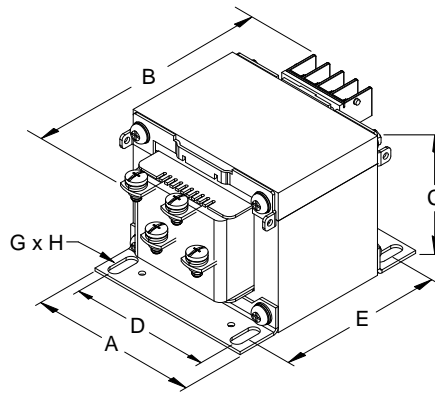

FIGURE B

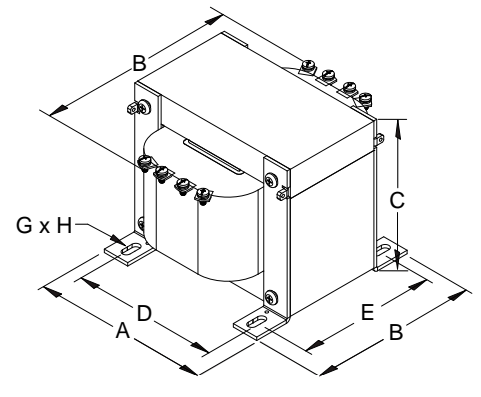

FIGURE C

Group A

Primary Voltage: 600/480 || 575/460 || 550/440
 Secondary Voltage: 120 X 240 || 115 X 230 || 110 X 220



VA Rating	CE VA Rating	Catalog Number	Mtg. Fig.	Output Amps	Overall Dimensions			Mounting Centers		Mounting Slot G X H	Height with Finger Guard	Height with Fuse Block Adapter	Approx. Ship Weight Lbs.
					A	B	C	D	E				
50	50	SP50ACP	A	0.42/0.21	2.60	3.82	2.60	2.13	2.64	0.22 x 0.44	2.98	2.79	2.2
100	100	SP100ACP	A	0.83/0.42	2.99	3.74	2.85	2.52	2.60	0.22 x 0.44	3.23	3.04	3.3
150	150	SP150ACP	A	1.25/0.63	2.99	4.29	2.85	2.52	3.15	0.22 x 0.44	3.23	3.04	4.4
250	160	SP250ACP	A	2.08/1.04	3.78	4.09	3.40	3.31	2.99	0.22 x 0.44	3.78	3.59	6.4
350	250	SP350ACP	A	2.92/1.46	3.78	4.49	3.40	3.31	3.39	0.22 x 0.44	3.78	3.59	7.5
500	300	SP500ACP	A	4.17/2.08	4.49	4.69	3.78	3.78	3.66	0.31 x 0.81	4.16	3.97	11
750	500	SP750ACP	A	6.25/3.13	5.25	5.08 ¹	4.37	4.50	4.06	0.31 x 0.81	4.75	4.56	18
1000	650	SP1000ACP	A	8.33/4.17	5.25	5.47 ¹	4.37	4.50	4.45	0.31 x 0.81	4.75	4.56	21
1500	1000	SP1500ACP	A	12.5/6.25	5.25	6.85 ¹	4.37	4.50	5.83	0.31 x 0.81	4.56	4.37	28
2000	1300	SP2000ACP	A	16.7/8.33	6.38	5.87 ¹	5.31	5.75	4.84	0.31 x 0.81	5.69	5.50	34
3000	2000	SP3000ACP	A	25.0/12.5	7.50	7.50	6.50	6.30	6.85	0.44 x 1.00	6.50	6.50	60
5000	3000	SP5000ACP	C	41.7/20.8	8.98	9.88	7.76	7.40	7.13	0.44 x 1.00	N/A	N/A	93

Primary and Secondary voltage links/jumpers supplied standard with all transformers. Refer to page 75 for wiring schematic drawing. All dimensions in inches
 Custom voltages and VA sizes available upon request.

¹ Note: For 750 through 2000 VA units actual overall depth is 0.24" plus the value in column B.

Group B

Primary Voltage: 600 || 575 || 550
 Secondary Voltage: 12 X 24 || 11.5 X 23 || 11 X 22



VA Rating	CE VA Rating	Catalog Number	Mtg. Fig.	Output Amps	Overall Dimensions			Mounting Centers		Mounting Slot G X H	Height with Finger Guard	Height with Fuse Block Adapter	Approx. Ship Weight Lbs.
					A	B	C	D	E				
50	50	SP50AR	A	4.17/2.08	2.60	3.23	2.60	2.13	2.05	0.22 x 0.44	2.98	2.79	1.5
100	100	SP100AR	A	8.33/4.17	2.99	3.74	2.85	2.52	2.60	0.22 x 0.44	3.23	3.04	3.3
150	150	SP150AR	A	12.5/6.25	2.99	4.09	2.85	2.52	2.95	0.22 x 0.44	3.23	3.04	3.9
250	160	SP250AR	A	20.8/10.4	3.78	3.70	3.40	3.31	2.60	0.22 x 0.44	3.78	3.59	5.2
350	250	SP350AR	A	29.2/14.6	3.78	4.29	3.40	3.31	3.19	0.22 x 0.44	3.78	3.59	7.1
500	300	SP500AR	B	41.7/20.8	4.49	5.08	3.78	3.78	3.27	0.31 x 0.81	4.16	3.97	9.9

Primary and Secondary voltage links/jumpers supplied standard with all transformers. All dimensions in inches
 Refer to page 75 for wiring schematic drawing. Custom voltages and VA sizes available upon request.

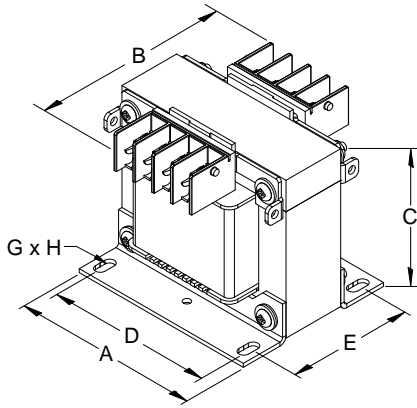

FIGURE A

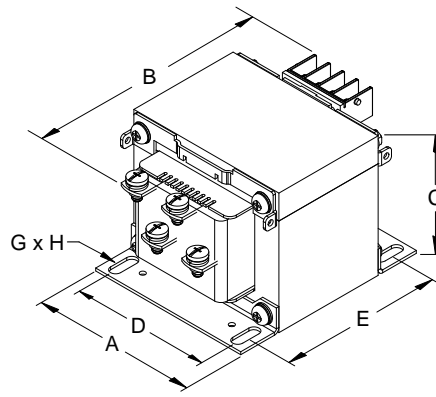

FIGURE B

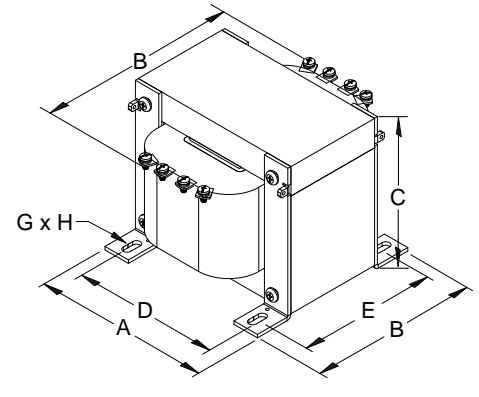

FIGURE C

Group C

Primary Voltage: 240 X 480 || 230 X 460 || 220 X 440
 Secondary Voltage: 120 X 240 || 115 X 230 || 110 X 220



 50/60 Hertz

VA Rating	CE VA Rating	Catalog Number	Mtg. Fig.	Output Amps	Overall Dimensions			Mounting Centers		Mounting Slot	Height with Finger Guard	Height with Fuse Block Adapter	Approx. Ship Weight Lbs.
					A	B	C	D	E	G X H			
50	50	SP50MQMJ	A	0.42/0.21	2.60	3.35	2.60	2.13	2.17	0.22 x 0.44	2.98	2.79	1.7
100	100	SP100MQMJ	A	0.83/0.42	2.99	3.74	2.85	2.52	2.60	0.22 x 0.44	3.23	3.04	3
150	150	SP150MQMJ	A	1.25/0.63	2.99	4.29	2.85	2.52	3.15	0.22 x 0.44	3.23	3.04	4.3
250	160	SP250MQMJ	A	2.08/1.04	3.78	4.09	3.40	3.31	2.99	0.22 x 0.44	3.78	3.59	6.5
350	250	SP350MQMJ	A	2.92/1.46	3.78	4.69	3.40	3.31	3.58	0.22 x 0.44	3.78	3.59	8.2
500	300	SP500MQMJ	A	4.17/2.08	4.49	4.69	3.78	3.78	3.66	0.31 x 0.81	4.16	3.97	11
750	500	SP750MQMJ	A	6.25/3.13	5.25	4.69 ¹	4.37	4.50	3.66	0.31 x 0.81	4.75	4.56	16
1000	650	SP1000MQMJ	A	8.33/4.17	5.25	5.47 ¹	4.37	4.50	4.45	0.31 x 0.81	4.75	4.56	21
1500	1000	SP1500MQMJ	A	12.5/6.25	5.25	6.85 ¹	4.37	4.50	5.83	0.31 x 0.81	4.75	4.56	28
2000	1300	SP2000MQMJ	A	16.7/8.33	6.38	5.87 ¹	5.31	5.75	4.84	0.31 x 0.81	5.50	5.31	35
3000	2000	SP3000MQMJ	A	25.0/12.5	7.50	7.50	6.50	6.30	7.28	0.44 x 1.00	6.50	6.50	64
5000	3000	SP5000MQMJ	C	41.7/20.8	8.98	9.88	7.76	7.40	7.28	0.44 x 1.00	N/A	N/A	97

Primary and Secondary voltage links/jumpers supplied standard with all transformers. All dimensions in inches
 Refer to page 76 for wiring schematic drawing. Custom voltages and VA sizes available upon request.
¹ Note: For 750 through 2000 VA units actual overall depth is 0.24" plus the value in column B.

Group D

Primary Voltage: 240 X 480 || 230 X 460 || 220 X 440
 Secondary Voltage: 12 X 24 || 11.5 X 23 || 11 X 22



 50/60 Hertz

VA Rating	CE VA Rating	Catalog Number	Mtg. Fig.	Output Amps	Overall Dimensions			Mounting Centers		Mounting Slot	Height with Finger Guard	Height with Fuse Block Adapter	Approx. Ship Weight Lbs.
					A	B	C	D	E	G X H			
50	50	SP50QR	A	4.17/2.08	2.60	3.35	2.60	2.13	2.17	0.22 x 0.44	2.98	2.79	1.7
100	100	SP100QR	A	8.33/4.17	2.99	3.54	2.85	2.52	2.40	0.22 x 0.44	3.23	3.04	3
150	150	SP150QR	A	12.5/6.25	2.99	4.29	2.85	2.52	3.15	0.22 x 0.44	3.23	3.04	4.3
250	160	SP250QR	A	20.8/10.4	3.78	4.09	3.40	3.31	2.99	0.22 x 0.44	3.78	3.59	6.5
350	250	SP350QR	A	29.2/14.6	3.78	4.69	3.40	3.31	3.58	0.22 x 0.44	3.78	3.59	8.3
500	300	SP500QR	B	41.7/20.8	4.49	5.47	3.78	3.78	3.66	0.31 x 0.81	4.16	3.97	11

Primary and Secondary voltage links/jumpers supplied standard with all transformers. All dimensions in inches
 Refer to page 76 for wiring schematic drawing. Custom voltages and VA sizes available upon request.



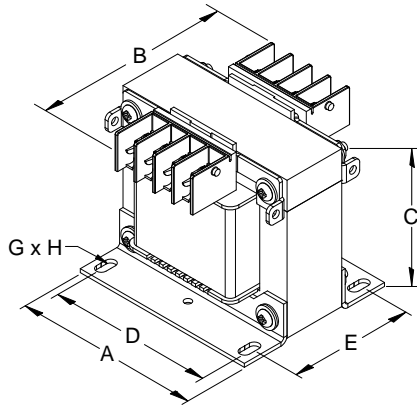

FIGURE A

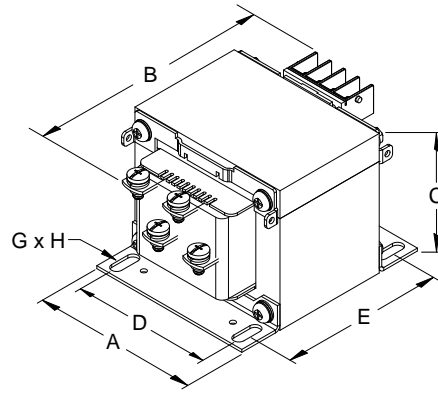

FIGURE B

Group E

Primary Voltage: **380/347**
 Secondary Voltage: **120 X 240**



VA Rating	CE VA Rating	Catalog Number	Mtg. Fig.	Output Amps	Overall Dimensions			Mounting Centers		Mounting Slot	Height with Finger Guard	Height with Fuse Block Adapter	Approx. Ship Weight Lbs.
					A	B	C	D	E	G X H			
50	50	SP50KHP	A	0.42/0.21	2.60	3.35	2.60	2.13	2.17	0.22 x 0.44	2.98	2.79	1.7
100	100	SP100KHP	A	0.83/0.42	2.99	3.74	2.85	2.52	2.60	0.22 x 0.44	3.23	3.04	3.4
150	150	SP150KHP	A	1.25/0.63	2.99	4.29	2.85	2.52	3.15	0.22 x 0.44	3.23	3.04	4.4
250	160	SP250KHP	A	2.08/1.04	3.78	4.09	3.40	3.31	2.99	0.22 x 0.44	3.78	3.59	6.7
350	250	SP350KHP	A	2.92/1.46	3.78	4.69	3.40	3.31	3.58	0.22 x 0.44	3.78	3.59	8.4
500	300	SP500KHP	A	4.17/2.08	4.49	4.69	3.78	3.78	3.66	0.31 x 0.81	4.16	3.97	12
750	500	SP750KHP	A	6.25/3.13	5.25	4.69 ¹	4.37	4.50	3.66	0.31 x 0.81	4.75	4.56	17
1000	650	SP1000KHP	A	8.33/4.17	5.25	5.47 ¹	4.37	4.50	4.45	0.31 x 0.81	4.75	4.56	21
1500	1000	SP1500KHP	A	12.5/6.25	6.38	4.88 ¹	5.31	5.75	3.86	0.31 x 0.81	5.50	5.31	29

Primary and Secondary voltage links/jumpers supplied standard with all transformers.
 Refer to page 77 for wiring schematic drawing. Custom voltages and VA sizes available upon request.
¹ Note: For 750 through 1500 VA units actual overall depth is 0.24" plus the value in column B.

All dimensions in inches

Group F

Primary Voltage: **380/347**
 Secondary Voltage: **12 X 24**



VA Rating	CE VA Rating	Catalog Number	Mtg. Fig.	Output Amps	Overall Dimensions			Mounting Centers		Mounting Slot	Height with Finger Guard	Height with Fuse Block Adapter	Approx. Ship Weight Lbs.
					A	B	C	D	E	G X H			
50	50	SP50KHR	A	4.17/2.08	2.60	3.35	2.60	2.13	2.17	0.22 x 0.44	2.98	2.79	1.7
100	100	SP100KHR	A	8.33/4.17	2.99	3.74	2.85	2.52	2.60	0.22 x 0.44	3.23	3.04	3.3
150	150	SP150KHR	A	12.5/6.25	2.99	4.29	2.85	2.52	3.15	0.22 x 0.44	3.23	3.04	4.4
250	160	SP250KHR	A	20.8/10.4	3.78	4.09	3.40	3.31	2.99	0.22 x 0.44	3.78	3.59	6.4
350	250	SP350KHR	A	29.2/14.6	3.78	4.69	3.40	3.31	3.58	0.22 x 0.44	3.78	3.59	8.1
500	300	SP500KHR	B	41.7/20.8	4.49	5.47	3.78	3.78	3.66	0.31 x 0.81	4.16	3.97	11

Primary and Secondary voltage links/jumpers supplied standard with all transformers.
 Refer to page 77 for wiring schematic drawing. Custom voltages and VA sizes available upon request.

All dimensions in inches

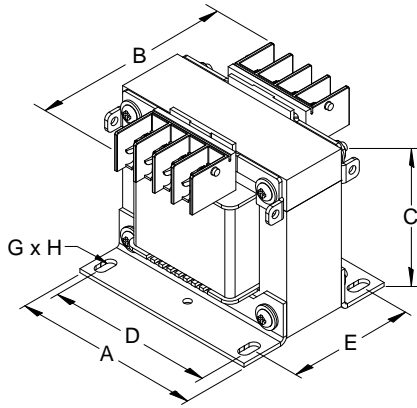

FIGURE A

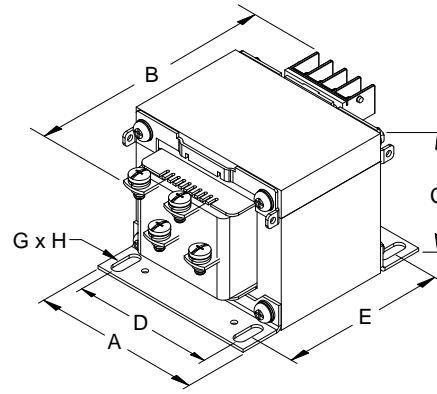

FIGURE B

Group G

Primary Voltage: 277

Secondary Voltage: 120



50/60 Hertz

VA Rating	CE VA Rating	Catalog Number	Mtg. Fig.	Output Amps	Overall Dimensions			Mounting Centers		Mounting Slot	Height with Finger Guard	Height with Fuse Block Adapter	Approx. Ship Weight Lbs.
					A	B	C	D	E	G X H			
50	50	SP50NJ	A	0.42	2.60	3.35	2.60	2.13	2.17	0.22 x 0.44	2.98	2.79	1.6
100	100	SP100NJ	A	0.83	2.99	3.54	2.85	2.52	2.40	0.22 x 0.44	3.23	3.04	3.2
150	150	SP150NJ	A	1.25	2.99	4.29	2.85	2.52	3.15	0.22 x 0.44	3.23	3.04	4.3
250	160	SP250NJ	A	2.08	3.78	4.09	3.40	3.31	2.99	0.22 x 0.44	3.78	3.59	6.4
350	250	SP350NJ	A	2.92	3.78	4.69	3.40	3.31	3.58	0.22 x 0.44	3.78	3.59	8.1
500	300	SP500NJ	A	4.17	4.49	4.69	3.78	3.78	3.66	0.31 x 0.81	4.16	3.97	11
750	500	SP750NJ	A	6.25	5.25	5.08 ¹	4.37	4.50	4.06	0.31 x 0.81	4.75	4.56	18
1000	650	SP1000NJ	A	8.33	5.25	5.47 ¹	4.37	4.50	4.45	0.31 x 0.81	4.75	4.56	20
1500	1000	SP1500NJ	A	12.50	5.25	6.85 ¹	4.37	4.50	5.83	0.31 x 0.81	4.75	4.56	29

Primary and Secondary voltage links/jumpers supplied standard with all transformers. Refer to page 78 for wiring schematic drawing. Custom voltages and VA sizes available upon request.
¹ Note: For 750 through 1500 VA units actual overall depth is 0.24" plus the value in column B.

All dimensions in inches

Group H

Primary Voltage: 120 X 240 || 115 X 230 || 110 X 220

Secondary Voltage: 12 X 24 || 11.5 X 23 || 11 X 22



50/60 Hertz

VA Rating	CE VA Rating	Catalog Number	Mtg. Fig.	Output Amps	Overall Dimensions			Mounting Centers		Mounting Slot	Height with Finger Guard	Height with Fuse Block Adapter	Approx. Ship Weight Lbs.
					A	B	C	D	E	G X H			
50	50	SP50PR	A	4.17/2.08	2.60	3.35	2.60	2.13	2.17	0.22 x 0.44	2.98	2.79	1.7
100	100	SP100PR	A	8.33/4.17	2.99	3.74	2.85	2.52	2.60	0.22 x 0.44	3.23	3.04	3
150	150	SP150PR	A	12.5/6.25	2.99	4.29	2.85	2.52	3.15	0.22 x 0.44	3.23	3.04	4.3
250	160	SP250PR	A	20.8/10.4	3.78	3.90	3.40	3.31	2.80	0.22 x 0.44	3.78	3.59	5.9
350	250	SP350PR	A	29.2/14.6	3.78	4.69	3.40	3.31	3.58	0.22 x 0.44	3.78	3.59	8.2
500	300	SP500PR	B	41.7/20.8	4.49	5.47	3.78	3.78	3.66	0.31 x 0.81	4.16	3.97	11

Primary and Secondary voltage links/jumpers supplied standard with all transformers. Refer to page 78 for wiring schematic drawing. Custom voltages and VA sizes available upon request.

All dimensions in inches



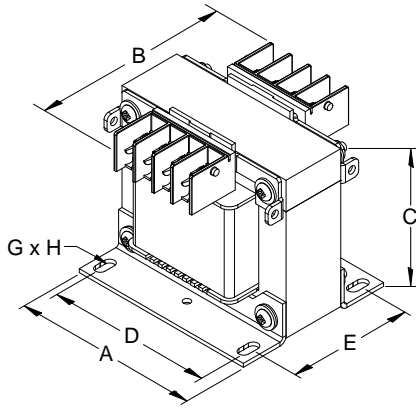

FIGURE A

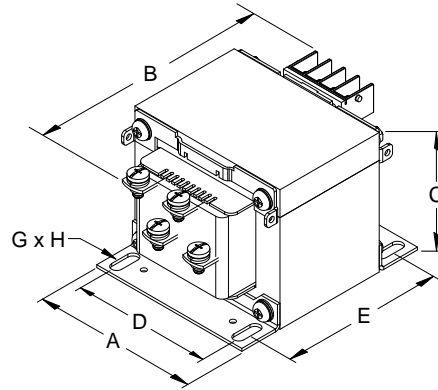

FIGURE B

Group I

Primary Voltage: 208 X 416 || 200 X 400 || 190 X 380
 Secondary Voltage: 120 X 240 || 115 X 230 || 110 X 220



50/60 Hertz

VA Rating	CE VA Rating	Catalog Number	Mtg. Fig.	Output Amps	Overall Dimensions			Mounting Centers		Mounting Slot	Height with Finger Guard	Height with Fuse Block Adapter	Approx. Ship Weight Lbs.
					A	B	C	D	E	G X H			
50	50	SP50SP	A	0.42/0.21	2.60	3.35	2.60	2.13	2.17	0.22 x 0.44	1.6	2.60	1.6
100	100	SP100SP	A	0.83/0.42	2.99	3.54	2.85	2.52	2.40	0.22 x 0.44	3	2.85	3
150	150	SP150SP	A	1.25/0.63	2.99	4.29	2.85	2.52	3.15	0.22 x 0.44	4.3	2.85	4.3
250	160	SP250SP	A	2.08/1.04	3.78	4.09	3.40	3.31	2.99	0.22 x 0.44	6.5	3.40	6.5
350	250	SP350SP	A	2.92/1.46	3.78	4.69	3.40	3.31	3.58	0.22 x 0.44	8.3	3.40	8.3
500	300	SP500SP	A	4.17/2.08	4.49	4.69	3.78	3.78	3.66	0.31 x 0.81	11	3.78	11
750	500	SP750SP	A	6.25/3.13	5.25	4.69 ¹	4.37	4.50	3.66	0.31 x 0.81	16	4.75	16
1000	650	SP1000SP	A	8.33/4.17	5.25	5.47 ¹	4.37	4.50	4.45	0.31 x 0.81	20	4.75	20
1500	1000	SP1500SP	A	12.5/6.25	6.38	4.88 ¹	5.31	5.75	3.86	0.31 x 0.81	27	5.69	27

Primary and Secondary voltage links/jumpers supplied standard with all transformers.
 Refer to page 79 for wiring schematic drawing. Custom voltages and VA sizes available upon request.

All dimensions in inches

¹ Note: For 750 through 1500 VA units actual overall depth is 0.24" plus the value in column B.

Group J

Primary Voltage: 208 X 416 || 200 X 400 || 190 X 380
 Secondary Voltage: 12 X 24 || 11.5 X 23 || 11 X 22



50/60 Hertz

VA Rating	CE VA Rating	Catalog Number	Mtg. Fig.	Output Amps	Overall Dimensions			Mounting Centers		Mounting Slot	Height with Finger Guard	Height with Fuse Block Adapter	Approx. Ship Weight Lbs.
					A	B	C	D	E	G X H			
50	50	SP50SR	A	4.17/2.08	2.60	3.35	2.60	2.13	2.17	0.22 x 0.44	2.98	2.79	1.6
100	100	SP100SR	A	8.33/4.17	2.99	3.54	2.85	2.52	2.40	0.22 x 0.44	3.23	3.04	3.1
150	150	SP150SR	A	12.5/6.25	2.99	4.29	2.85	2.52	3.15	0.22 x 0.44	3.23	3.04	4.3
250	160	SP250SR	A	20.8/10.4	3.78	4.09	3.40	3.31	2.99	0.22 x 0.44	3.78	3.59	6.5
350	250	SP350SR	A	29.2/14.6	3.78	4.69	3.40	3.31	3.58	0.22 x 0.44	3.78	3.59	8.3
500	300	SP500SR	B	41.7/20.8	4.49	5.47	3.78	3.78	3.66	0.31 x 0.81	4.16	3.97	11

Primary and Secondary voltage links/jumpers supplied standard with all transformers.
 Refer to page 79 for wiring schematic drawing. Custom voltages and VA sizes available upon request.

All dimensions in inches



Optional Accessories

Finger Guards

HPS Spartan industrial control transformers up to and including 3000VA or 30 amps are available with optional finger guards.

Part Number	Applicable Transformer Part Number Suffixes	Applicable VA Sizes
SPFG1	AR, QR, PR, KHR, SR	50 to 500
SPFG1	KHP, SP, NJ	50 to 1500
SPFG1	ACP, MQMJ	50 to 3000

Note: Each finger guard supplies either the primary or secondary side. Finger guard option not available on SP5000ACP and SP5000MQMJ standard units. Add 0.38" per finger guard to overall depth (column B) on units from 50 VA to 500 VA and 0.31" to units from 750 VA to 2000 VA when finger guard has been installed. For custom units, optional finger guards are only available on units up to 3000VA or 30 amps.

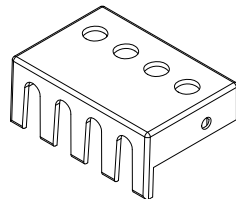

Finger Guard
(Optional)

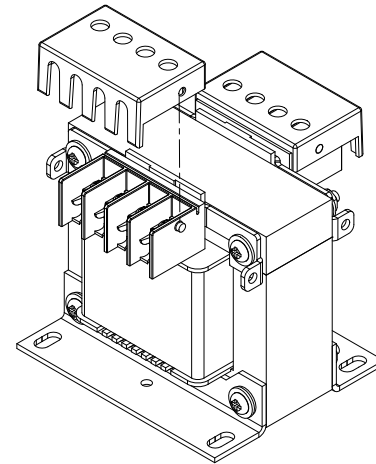

Sample Assembly Drawing for Optional Finger Guard Installation
(Only available for units supplied with either a primary or secondary molded terminal block)

Fuse Block Adapter Kit

HPS Spartan industrial control transformers up to and including 3000VA or 30 amps are available with optional fuse block adapter kits. The Fuse Block Adapter Kit is designed to allow for the installation of any third party after market fuse block assembly onto the industrial control transformer. The transformer must be a unit that incorporates a molded terminal block on either the primary or secondary side.

Note: HPS does not provide any jumpers or appropriate fuses for any after market fuse block you install on the HPS Spartan industrial control transformer. The HPS fuse block adapter kit provides only the mechanical means of attaching a third party after market fuse block. HPS does not recommend any specific fuse block or fuse supplier. For a recommended size of fuse, please see page # 32.

Kit Part Number	Applicable Transformer Part Number Suffixes	Applicable VA Sizes
SPFBAK1	AR, QR, PR, KHR, SR	50 to 500
SPFBAK1	KHP, SP, NJ	50 to 1500
SPFBAK1	ACP, MQMJ	50 to 3000

Note: Only 1 fuse block adapter kit is required per transformer. Fuse block adapter kit not available on SP5000ACP and SP5000MQMJ standard units. Add 0.38" per fuse block adapter to overall depth (column B) on units from 750 VA to 3000 VA when optional fuse block adapter is installed. For custom units, optional fuse block adapter kit is only available on units up to 3000VA or 30 amps.

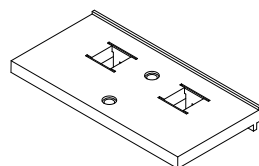

Fuse Block Adapter Kit
(Optional)

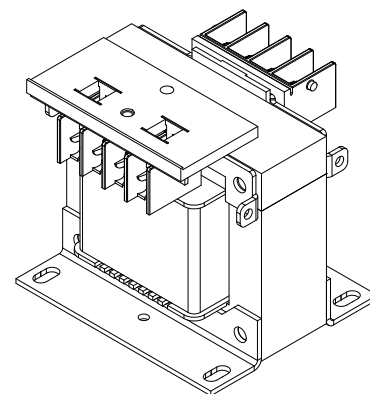

Sample Assembly Drawing for Optional Fuse Block Adapter Installation

For detailed installation instructions of HPS Spartan transformers or the optional finger guards and fuse block adapter kits, please visit our website under Products and Services - Literature & Resources - Instruction Sheets - Control Transformers. Or go to the following link: http://www.hammondpowersolutions.com/products/product_literature/instruction_sheets/control_transformers.php

HPS Fusion™ General Purpose Enclosed Transformer

The Ideal Solution

The HPS Fusion™ line of single phase, general purpose enclosed transformers are ideally suited for general purpose, industrial and light duty loads. They have been designed for indoor applications and offer an efficient and economical solution. These units are well suited for HVAC applications, signal and alarm systems, motor control circuits, lighting and circuit isolation.

The HPS Fusion control transformer is an enclosed style unit with either molded terminal blocks (on units up to 3000 VA or 30 amps) or coil face termination. Optional Finger guards and a fuse block adapter kit are available upon request.

For an economical approach to general purpose loads, the HPS Fusion is the transformer of choice.



STANDARDS		
The HPS Fusion Control Transformers meet or exceed the standards established by UL, CSA, IEC and NEMA.		
Standard	File #	VA Size
UL (ANSI/UL506)	E50394	All
CSA	LR3902	All
IEC 61558		All
NEMA (ST-1)		All



Features and Benefits

- Molded terminal blocks for primary and secondary connections up to 3000 VA or 30 amps; coil face termination over 3000VA or 30 amps
- All terminal blocks utilize a combination slot/Phillips #6 screw with a SEMS washer (suitable for 18 AWG to 14 AWG for solid wire and 18 AWG to 12 AWG for stranded wire). Coil face terminations utilize a ¼ - 20 UNC X 0.50" combination slot/Phillips screw and a spring lock washer
- Vacuum Impregnated with Polyester Resin and oven cured
- Bolted core construction
- Bolt-on mounting brackets
- Coils with high dielectric strength insulation
- Seismically certified in accordance with 2009 IBC for $S_{DS} \leq 2.00g$, $z/h = 1.0$ and $I_p = 1.5$
- CSA Certified, UL Listed, CE Marked and RoHS compliant
- Meets NEMA standards
- Superior insulating materials. The HPS Fusion series transformers offer the following insulation systems:

Up to 1500 VA:	95°C temperature rise, 130°C insulation class (B)
2000 VA to 5000 VA:	130°C temperature rise, 180°C insulation class (F)

(Note: Temperature rise based on 25°C ambient)
- 50/60 Hz (60 Hz on FS***ACP and FS***AR)
- Rugged NEMA 1 enclosure
- Finish - forest green powder coat
- Primary and secondary ground screw
- Four (0.88") wiring knockouts and four (0.50") accessory knockouts
- Optional panel mount fuse holder available
- Easy mounting and installation via four mounting slots and two keyhole slots
- Easy access to primary and secondary wiring compartments through removable covers
- 15 year warranty



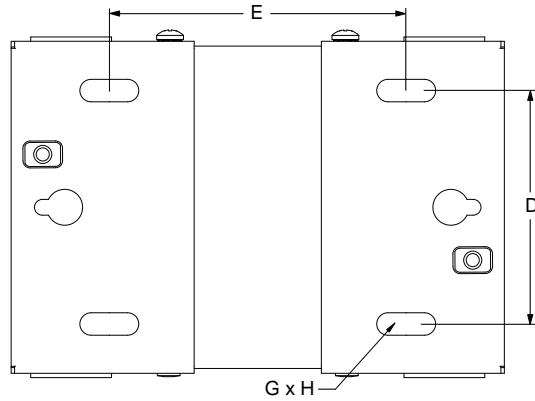
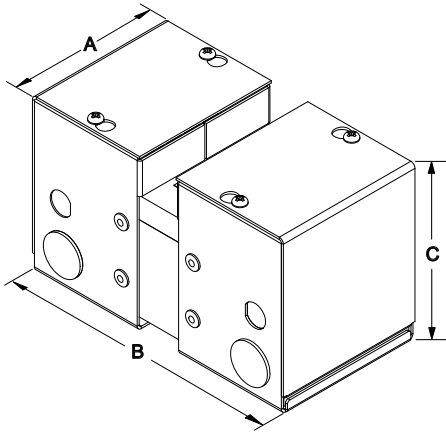

SECTION 1

Group A

Primary Voltage: 600/480 || 575/460 || 550/440
Secondary Voltage: 120 X 240 || 115 X 230 || 110 X 220



60 Hertz

VA Rating	CE VA Rating	Catalog Number	Output Amps	Overall Dimensions			Mounting Centers		Mounting Slot	Approx. Ship Weight Lbs.
				A	B	C	D	E	G X H	
50	50	FS50ACP	0.42/0.21	2.7	6.4	3.33	1.66	4.16	0.22 x 0.44	3.0
100	100	FS100ACP	0.83/0.42	3.09	6.3	3.6	2.05	3.5	0.22 x 0.44	4.2
150	150	FS150ACP	1.25/0.63	3.09	6.9	3.6	2.05	4.1	0.22 x 0.44	5.3
250	160	FS250ACP	2.08/1.04	3.9	6.6	4.3	2.52	3.9	0.22 x 0.44	7.6
350	250	FS350ACP	2.92/1.46	3.9	7	4.3	2.52	4.3	0.22 x 0.44	8.7
500	300	FS500ACP	4.17/2.08	4.6	7.2	4.6	3.3	4.5	0.31 x 0.81	13.3
750	500	FS750ACP	6.25/3.13	5.6	7.6	5.1	4	4.9	0.31 x 0.81	20.3
1000	650	FS1000ACP	8.33/4.17	5.6	8	5.1	4	5.3	0.31 x 0.81	22.9
1500	1000	FS1500ACP	12.5/6.25	5.6	9.4	5.1	4	6.7	0.31 x 0.81	30.3
2000	1300	FS2000ACP	16.7/8.33	6.6	9.1	6	5.1	5.7	0.31 x 0.81	37.1
3000	2000	FS3000ACP	25.0/12.5	7.8	11.3	6.7	6.3	6.9	0.31 x 0.81	64.0
5000	3000	FS5000ACP	41.7/20.8	9.3	14.9	8	7.1	7.3	0.31 x 0.81	99.7

Primary and Secondary voltage links/jumpers supplied standard with all transformers. Refer to page 75 for wiring schematic drawing. Custom voltages and VA sizes available upon request.

All dimensions in inches

Group B

Primary Voltage: 600 || 575 || 550
Secondary Voltage: 12 X 24 || 11.5 X 23 || 11 X 22



60 Hertz

VA Rating	CE VA Rating	Catalog Number	Output Amps	Overall Dimensions			Mounting Centers		Mounting Slot	Approx. Ship Weight Lbs.
				A	B	C	D	E	G X H	
50	50	FS50AR	4.17/2.08	2.7	5.8	3.33	1.66	3.58	0.22 x 0.44	2.3
100	100	FS100AR	8.33/4.17	3.09	6.3	3.6	2.05	3.5	0.22 x 0.44	4.2
150	150	FS150AR	12.5/6.25	3.09	6.7	3.6	2.05	3.9	0.22 x 0.44	4.8
250	160	FS250AR	20.8/10.4	3.9	6.2	4.3	2.52	3.5	0.22 x 0.44	6.4
350	250	FS350AR	29.2/14.6	3.9	6.8	4.3	2.52	4.1	0.22 x 0.44	8.3
500	300	FS500AR	41.7/20.8	4.6	6.8	4.1	3.3	4.5	0.31 x 0.81	11.8

Primary and Secondary voltage links/jumpers supplied standard with all transformers. Refer to page 75 for wiring schematic drawing. Custom voltages and VA sizes available upon request.

All dimensions in inches



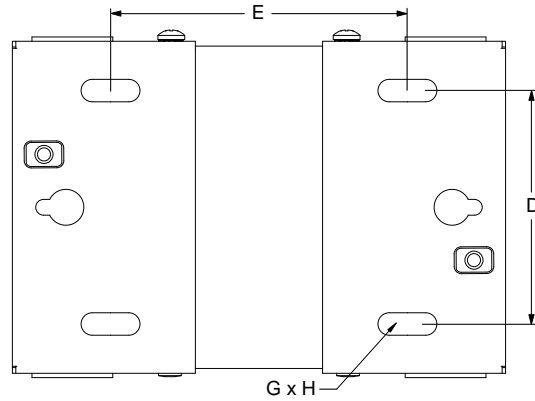
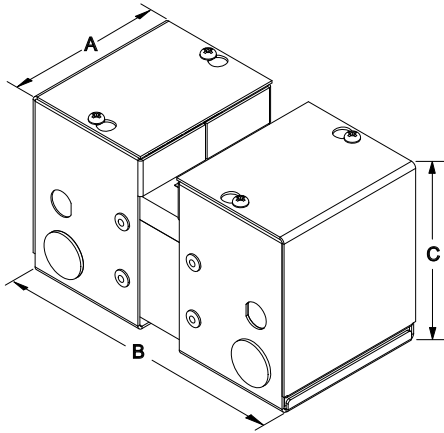

Group C

Primary Voltage: 240 X 480 || 230 X 460 || 220 X 440
 Secondary Voltage: 120 X 240 || 115 X 230 || 110 X 220



50/60 Hertz

VA Rating	CE VA Rating	Catalog Number	Output Amps	Overall Dimensions			Mounting Centers		Mounting Slot	Approx. Ship Weight Lbs.
				A	B	C	D	E	G X H	
50	50	FS50MQMJ	0.42/0.21	2.7	5.9	3.33	1.66	3.69	0.22 x 0.44	2.5
100	100	FS100MQMJ	0.83/0.42	3.09	6.3	3.6	2.05	3.5	0.22 x 0.44	3.9
150	150	FS150MQMJ	1.25/0.63	3.09	6.9	3.6	2.05	4.1	0.22 x 0.44	5.2
250	160	FS250MQMJ	2.08/1.04	3.9	6.6	4.3	2.52	3.9	0.22 x 0.44	7.7
350	250	FS350MQMJ	2.92/1.46	3.9	7.2	4.3	2.52	4.9	0.22 x 0.44	9.4
500	300	FS500MQMJ	4.17/2.08	4.6	7.2	4.6	3.3	4.5	0.31 x 0.81	13.2
750	500	FS750MQMJ	6.25/3.13	5.6	7.2	5.1	4	4.5	0.31 x 0.81	18.0
1000	650	FS1000MQMJ	8.33/4.17	5.6	8	5.1	4	5.3	0.31 x 0.81	22.8
1500	1000	FS1500MQMJ	12.5/6.25	6.6	8.5	6	5.1	5.1	0.31 x 0.81	31.1
2000	1300	FS2000MQMJ	16.7/8.33	6.6	9.1	6	5.1	5.7	0.31 x 0.81	38.1
3000	2000	FS3000MQMJ	25.0/12.5	7.8	11.7	6.7	6.3	7.3	0.31 x 0.81	68.5
5000	3000	FS5000MQMJ	41.7/20.8	9.3	15.1	8	7.4	7.3	0.31 x 0.81	104.2

Primary and Secondary voltage links/jumpers supplied standard with all transformers.
 Refer to page 76 for wiring schematic drawing. Custom voltages and VA sizes available upon request.

All dimensions in inches

Group D

Primary Voltage: 240 X 480 || 230 X 460 || 220 X 440
 Secondary Voltage: 12 X 24 || 11.5 X 23 || 11 X 22



50/60 Hertz

VA Rating	CE VA Rating	Catalog Number	Output Amps	Overall Dimensions			Mounting Centers		Mounting Slot	Approx. Ship Weight Lbs.
				A	B	C	D	E	G X H	
50	50	FS50QR	4.17/2.08	2.7	5.9	3.33	1.66	3.69	0.22 x 0.44	2.5
100	100	FS100QR	8.33/4.17	3.09	6.1	3.6	2.05	3.35	0.22 x 0.44	3.9
150	150	FS150QR	12.5/6.25	3.09	6.9	3.6	2.05	4.1	0.22 x 0.44	5.2
250	160	FS250QR	20.8/10.4	3.9	6.6	4.3	2.52	3.9	0.22 x 0.44	7.7
350	250	FS350QR	29.2/14.6	3.9	7.2	4.3	2.52	4.9	0.22 x 0.44	9.5
500	300	FS500QR	41.7/20.8	4.6	7.2	4.6	3.3	4.5	0.31 x 0.81	13.4

Primary and Secondary voltage links/jumpers supplied standard with all transformers.
 Refer to page 76 for wiring schematic drawing. Custom voltages and VA sizes available upon request.

All dimensions in inches



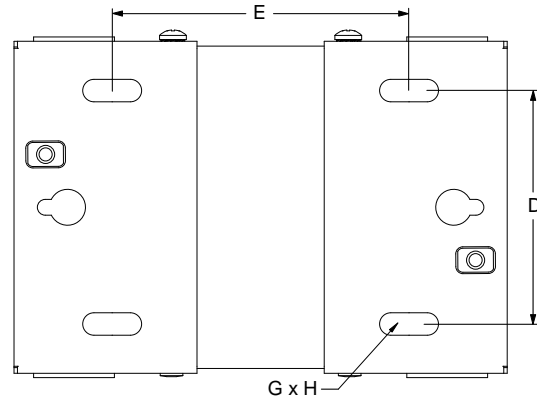
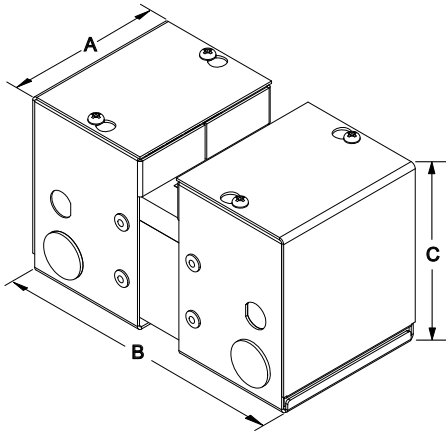

SECTION 1

Group E

Primary Voltage: 380/347
Secondary Voltage: 120 X 240



VA Rating	CE VA Rating	Catalog Number	Output Amps	Overall Dimensions			Mounting Centers		Mounting Slot	Approx. Ship Weight Lbs.
				A	B	C	D	E	G X H	
50	50	FS50KHP	0.42/0.21	2.7	5.9	3.33	1.66	3.69	0.22 x 0.44	2.5
100	100	FS100KHP	0.83/0.42	3.09	6.3	3.6	2.05	3.5	0.22 x 0.44	4.3
150	150	FS150KHP	1.25/0.63	3.09	6.9	3.6	2.05	4.1	0.22 x 0.44	5.3
250	160	FS250KHP	2.08/1.04	3.9	6.6	4.3	2.52	3.9	0.22 x 0.44	7.9
350	250	FS350KHP	2.92/1.46	3.9	7.2	4.3	2.52	4.9	0.22 x 0.44	9.6
500	300	FS500KHP	4.17/2.08	4.6	7.2	4.6	3.3	4.5	0.31 x 0.81	13.6
750	500	FS750KHP	6.25/3.13	5.6	7.2	5.1	4	4.5	0.31 x 0.81	19
1000	650	FS1000KHP	8.33/4.17	5.6	8	5.1	4	5.3	0.31 x 0.81	23.5
1500	1000	FS1500KHP	12.5/6.25	6.6	8.5	6	5.1	5.1	0.31 x 0.81	31.6

Primary and Secondary voltage links/jumpers supplied standard with all transformers.
 Refer to page 77 for wiring schematic drawing. Custom voltages and VA sizes available upon request.

All dimensions in inches

Group F

Primary Voltage: 380/347
Secondary Voltage: 12 X 24



VA Rating	CE VA Rating	Catalog Number	Output Amps	Overall Dimensions			Mounting Centers		Mounting Slot	Approx. Ship Weight Lbs.
				A	B	C	D	E	G X H	
50	50	FS50KHR	4.17/2.08	2.7	5.9	3.33	1.66	3.69	0.22 x 0.44	2.5
100	100	FS100KHR	8.33/4.17	3.09	6.3	3.6	2.05	3.5	0.22 x 0.44	4.2
150	150	FS150KHR	12.5/6.25	3.09	6.9	3.6	2.05	4.1	0.22 x 0.44	5.3
250	160	FS250KHR	20.8/10.4	3.9	6.6	4.3	2.52	3.9	0.22 x 0.44	7.6
350	250	FS350KHR	29.2/14.6	3.9	7.2	4.3	2.52	4.9	0.22 x 0.44	9.3
500	300	FS500KHR	41.7/20.8	4.6	7.2	4.6	3.3	4.5	0.31 x 0.81	13.2

Primary and Secondary voltage links/jumpers supplied standard with all transformers.
 Refer to page 77 for wiring schematic drawing. Custom voltages and VA sizes available upon request.

All dimensions in inches



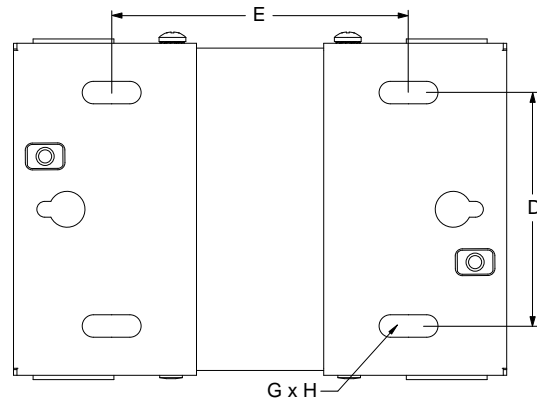
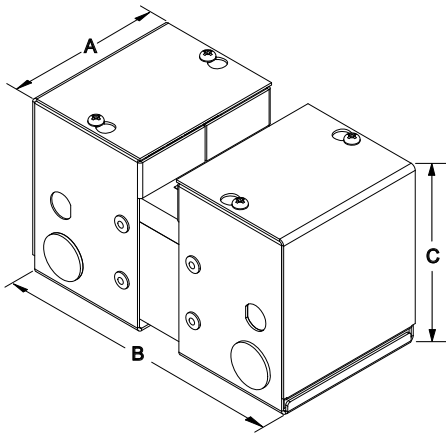

Group G

Primary Voltage: 277
Secondary Voltage: 120



50/60 Hertz

VA Rating	CE VA Rating	Catalog Number	Output Amps	Overall Dimensions			Mounting Centers		Mounting Slot	Approx. Ship Weight Lbs.
				A	B	C	D	E	G X H	
50	50	FS50NJ	0.42	2.7	5.9	3.33	1.66	3.69	0.22 x 0.44	2.4
100	100	FS100NJ	0.83	3.09	6.1	3.6	2.05	3.35	0.22 x 0.44	4.1
150	150	FS150NJ	1.25	3.09	6.9	3.6	2.05	4.1	0.22 x 0.44	5.2
250	160	FS250NJ	2.08	3.9	6.6	4.3	2.52	3.9	0.22 x 0.44	7.6
350	250	FS350NJ	2.92	3.9	7.2	4.3	2.52	4.9	0.22 x 0.44	9.3
500	300	FS500NJ	4.17	4.6	7.2	4.6	3.3	4.5	0.31 x 0.81	13.3
750	500	FS750NJ	6.25	5.6	7.6	5.1	4	4.9	0.31 x 0.81	20.1
1000	650	FS1000NJ	8.33	5.6	8	5.1	4	5.3	0.31 x 0.81	22.8
1500	1000	FS1500NJ	12.50	5.6	9.4	5.1	4	6.7	0.31 x 0.81	31.1

Primary and Secondary voltage links/jumpers supplied standard with all transformers. All dimensions in inches
 Refer to page 78 for wiring schematic drawing. Custom voltages and VA sizes available upon request.

Group H

Primary Voltage: 120 X 240 || 115 X 230 || 110 X 220
Secondary Voltage: 12 X 24 || 11.5 X 23 || 11 X 22



50/60 Hertz

VA Rating	CE VA Rating	Catalog Number	Output Amps	Overall Dimensions			Mounting Centers		Mounting Slot	Approx. Ship Weight Lbs.
				A	B	C	D	E	G X H	
50	50	FS50PR	4.17/2.08	2.7	5.9	3.33	1.66	3.69	0.22 x 0.44	2.5
100	100	FS100PR	8.33/4.17	3.09	6.1	3.6	2.05	3.35	0.22 x 0.44	3.9
150	150	FS150PR	12.5/6.25	3.09	6.9	3.6	2.05	4.1	0.22 x 0.44	5.2
250	160	FS250PR	20.8/10.4	3.9	6.4	4.3	2.52	3.7	0.22 x 0.44	7.1
350	250	FS350PR	29.2/14.6	3.9	7.2	4.3	2.52	4.9	0.22 x 0.44	9.4
500	300	FS500PR	41.7/20.8	4.6	7.2	4.6	3.3	4.5	0.31 x 0.81	13.2

Primary and Secondary voltage links/jumpers supplied standard with all transformers. All dimensions in inches
 Refer to page 78 for wiring schematic drawing. Custom voltages and VA sizes available upon request.

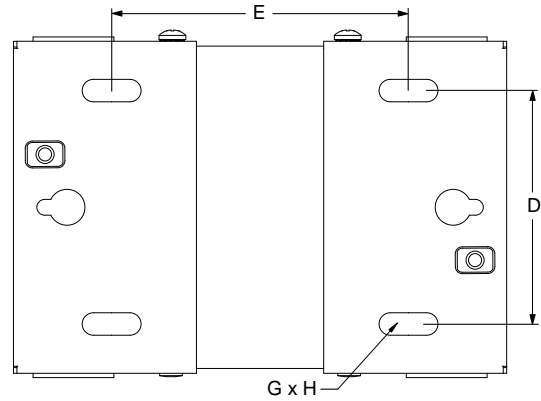
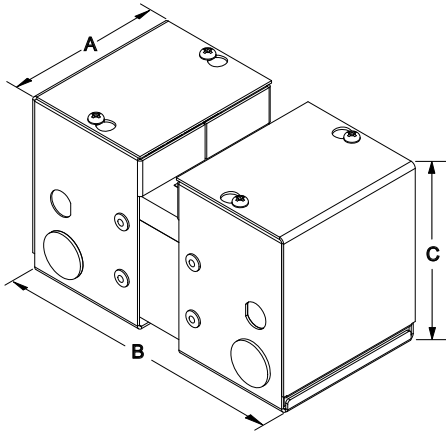

Group I

Primary Voltage: 208 X 416 || 200 X 400 || 190 X 380
 Secondary Voltage: 120 X 240 || 115 X 230 || 110 X 220



50/60 Hertz

VA Rating	CE VA Rating	Catalog Number	Output Amps	Overall Dimensions			Mounting Centers		Mounting Slot	Approx. Ship Weight Lbs.
				A	B	C	D	E	G X H	
50	50	FS50SP	0.42/0.21	2.7	5.9	3.33	1.66	3.69	0.22 x 0.44	2.4
100	100	FS100SP	0.83/0.42	3.09	6.1	3.6	2.05	3.35	0.22 x 0.44	3.9
150	150	FS150SP	1.25/0.63	3.09	6.9	3.6	2.05	4.1	0.22 x 0.44	5.2
250	160	FS250SP	2.08/1.04	3.9	6.6	4.3	2.52	3.9	0.22 x 0.44	7.7
350	250	FS350SP	2.92/1.46	3.9	7.2	4.3	2.52	4.9	0.22 x 0.44	9.5
500	300	FS500SP	4.17/2.08	4.6	7.2	4.6	3.3	4.5	0.31 x 0.81	13.3
750	500	FS750SP	6.25/3.13	5.6	7.2	5.1	4	4.5	0.31 x 0.81	18.2
1000	650	FS1000SP	8.33/4.17	5.6	8	5.1	4	5.3	0.31 x 0.81	22.5
1500	1000	FS1500SP	12.5/6.25	6.6	8.5	6	5.1	5.1	0.31 x 0.81	30.1

Primary and Secondary voltage links/jumpers supplied standard with all transformers.
 Refer to page 79 for wiring schematic drawing. Custom voltages and VA sizes available upon request.

All dimensions in inches

Group J

Primary Voltage: 208 X 416 || 200 X 400 || 190 X 380
 Secondary Voltage: 12 X 24 || 11.5 X 23 || 11 X 22



50/60 Hertz

VA Rating	CE VA Rating	Catalog Number	Output Amps	Overall Dimensions			Mounting Centers		Mounting Slot	Approx. Ship Weight Lbs.
				A	B	C	D	E	G X H	
50	50	FS50SR	4.17/2.08	2.7	5.9	3.33	1.66	3.69	0.22 x 0.44	2.4
100	100	FS100SR	8.33/4.17	3.09	6.1	3.6	2.05	3.35	0.22 x 0.44	4
150	150	FS150SR	12.5/6.25	3.09	6.9	3.6	2.05	4.1	0.22 x 0.44	5.2
250	160	FS250SR	20.8/10.4	3.9	6.6	4.3	2.52	3.9	0.22 x 0.44	7.7
350	250	FS350SR	29.2/14.6	3.9	7.2	4.3	2.52	4.9	0.22 x 0.44	9.5
500	300	FS500SR	41.7/20.8	4.6	7.2	4.6	3.3	4.5	0.31 x 0.81	13.3

Primary and Secondary voltage links/jumpers supplied standard with all transformers.
 Refer to page 79 for wiring schematic drawing. Custom voltages and VA sizes available upon request.

All dimensions in inches

Optional Accessories

Fuse Holder Kit

This general purpose enclosed transformer optional secondary fuse holder kit is specifically designed to provide circuit protection up to a maximum of 20 amps and up to 250V. The fuse holder kit is supplied with leads for easy hook-up and is easy to install. Fuses are NOT supplied with this kit. Fuses should be selected in accordance with CSA, UL and local electrical codes.

Part Number	Applicable Transformer Part Number Suffixes	Applicable Specifications
FSFH1	All	Up to 20 amps and 250V

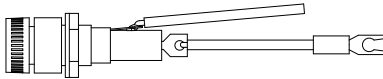

Fuse Kit
(Optional)

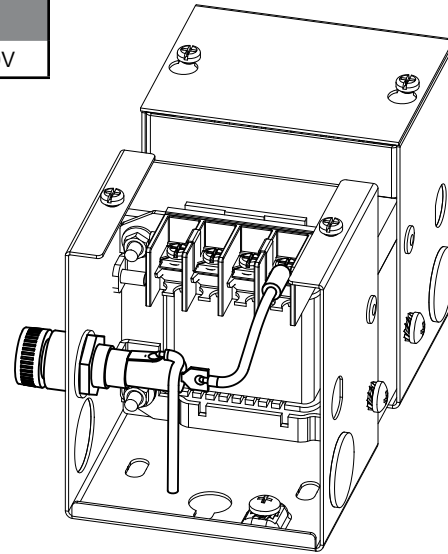

**Sample Assembly Drawing for
Optional Fuse Kit Installation**
(Only available for units supplied with either a primary or secondary molded terminal block)

For detailed installation instructions of HPS Fusion transformers or the optional fuse kits, please visit our website under **Products and Services - Literature & Resources - Instruction Sheets - Control Transformers**.

Or go to the following link: http://www.hammondpowersolutions.com/products/product_literature/instruction_sheets/control_transformers.php

SINGLE PHASE ENCLOSED ENCAPSULATED CONTROL TRANSFORMER FEATURES

For applications where a cost effective approach to general purpose loads indoor or outdoor is required, consider the 'Q' series, single phase encapsulated control transformer. These units are specifically designed for the following applications;

- General purpose enclosed control applications used to adjust a supply voltage to match a load requirement.
- Supplying machine tool circuits.
- Actuating relays, bells, signal and alarm systems.
- Operating small motors, valves and dampers.
- Industrial lighting and circuit isolation.

50 to 5000VA



SINGLE PHASE ENCLOSED ENCAPSULATED CONTROL STANDARD SPECIFICATIONS

	50 to 5000VA	Benefits
UL Listed	File: E50394	
CSA Certified	File: LR3902	
Frequency	60 Hertz	
Insulation System	Up to 1kVA; Class B, 80°C temperature rise. 1.5 to 5kVA; Class F, 115°C temperature rise.	Assures long life and reliable performance.
Standard Design	Single Phase, all welded core construction made with high quality, high permeability silicon steel laminations. Computer designed coils, accurately wound with optimum mean turns made from high quality magnetic wire with insulation film.	Rugged one-piece assembly with low noise provides optimum performance and reliability. Provides enhanced voltage regulation, excellent thermal characteristics and compliments modern winding techniques.
Encapsulation	All units from 50VA to 5kVA are encapsulated with electrical grade silica sand and resin compounds.	Completely encloses the core and coil to seal out moisture, airborne contaminants and eliminates corrosion & insulation deterioration.
Enclosure Type	Heavy Duty NEMA Type 3R (conduit knockouts on sides and rear)	Meets the heavy industrial trade requirements for indoor/outdoor enclosed transformers.
Termination	Front accessible wiring compartment with high and low voltage copper lead wires or tabs.	Ample space for transformer connection for primary and secondary terminations.
Mounting	Designed for vertical or horizontal mounting.	Facilitates any installation requirement.

SINGLE PHASE, NEMA 3R STYLE ENCLOSURE



SECTION 1

600 Primary Volts

12/24 Secondary Volts

60 Hz

VA Rating	Catalog Number	Case Style (Page 262)	Approx. Dimensions (Inches)			Approx. Weight (Lbs.)	Mtg Type W - Wall	Wiring Diagram (Page 277)
			Width	Depth	Height			
50	QC05PRCB	NQ0	3.75	5.25	7.25	6	W	SCD 4
100	QC10PRCB	NQ0	3.75	5.25	7.25	7	W	SCD 4
150	QC15PRCB	NQ0	3.75	5.25	7.25	8	W	SCD 4
200	QC20PRCB	NQ1	4.50	5.75	7.25	11	W	SCD 4
250	QC25PRCB	NQ1	4.50	5.75	7.25	13	W	SCD 4
350	QC35PRCB	NQ1	4.50	5.75	7.25	14	W	SCD 4
500	QC50PRCB	NQ2	5.00	4.75	9.25	15	W	SCD 4
750	QC75PRCB	NQ2	5.00	4.75	9.25	18	W	SCD 4
1000	Q1C0PRCB	NQ3	5.88	5.50	10.50	25	W	SCD 4
1500	Q1C5PRCF	NQ4	7.00	6.50	11.75	36	W	SCD 4
2000	Q002PRCF	NQ4	7.00	6.50	11.75	46	W	SCD 4
3000	Q003PRCF	NQ4	7.00	6.50	11.75	65	W	SCD 4
5000	Q005PRCF	NQ5	10.00	7.75	17.25	105	W	SCD 4



HPS IMPERATOR - Wiring Schematic Drawings

Group A

SECTION 1

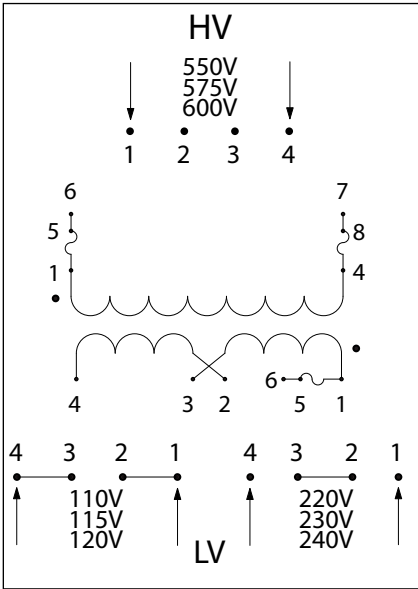

PH*AJ Schematic for 50, 75 and 100VA Units**

High Voltage (HV) (Primary Volts)	Install Supplied Jumpers/ Links Between Terminals	Supply Lines Connect To	Install Fuse Clips To
600 575 550	None	1, 4	Unfused
600 575 550	None	6, 7	1-5, 4-8

Low Voltage (LV) (Secondary Volts)	Install Supplied Links Between Terminals	Load Lines Connect To	Install Fuse Clips To
120 115 110	3-4, 1-2	1, 4	Unfused
240 230 220	2-3	1, 4	Unfused
120 115 110	3-4, 1-2	4, 6	1-5
240 230 220	2-3	4, 6	1-5

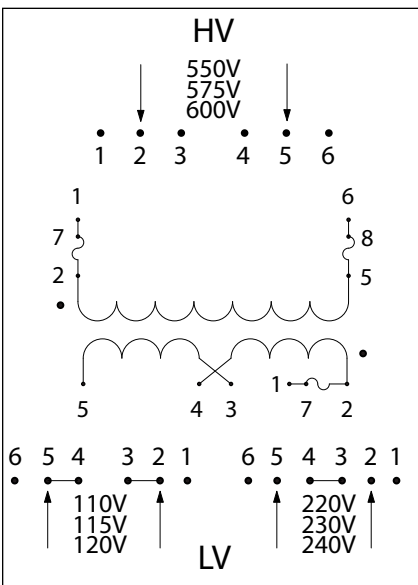

PH*AJ Schematic for 150VA to 1500VA Units**

High Voltage (HV) (Primary Volts)	Install Supplied Jumpers/ Links Between Terminals	Supply Lines Connect To	Install Fuse Clips To
600 575 550	None	2, 5	Unfused
600 575 550	None	1, 6	2-7, 5-8

Low Voltage (LV) (Secondary Volts)	Install Supplied Links Between Terminals	Load Lines Connect To	Install Fuse Clips To
120 115 110	4-5, 2-3	2, 5	Unfused
240 230 220	3-4	2, 5	Unfused
120 115 110	4-5, 2-3	1, 5	2-7
240 230 220	3-4	1, 5	2-7

HPS IMPERATOR - Wiring Schematic Drawings continued

Group B

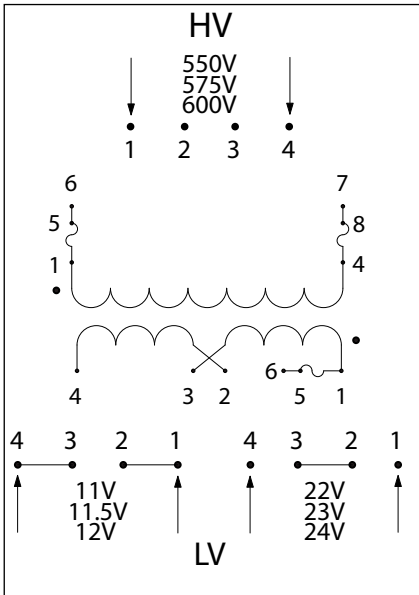

PH*** AR Schematic for 50, 75 and 100VA Units

High Voltage (HV) (Primary Volts)	Install Supplied Jumpers/ Links Between Terminals	Supply Lines Connect To	Install Fuse Clips To
600 575 550	None	1, 4	Unfused
600 575 550	None	6, 7	1-5, 4-8

Low Voltage (LV) (Secondary Volts)	Install Supplied Links Between Terminals	Load Lines Connect To	Install Fuse Clips To
12 11.5 11	3-4, 1-2	1, 4	Unfused
24 23 22	2-3	1, 4	Unfused
12 11.5 11	3-4, 1-2	4, 6	1-5
24 23 22	2-3	4, 6	1-5

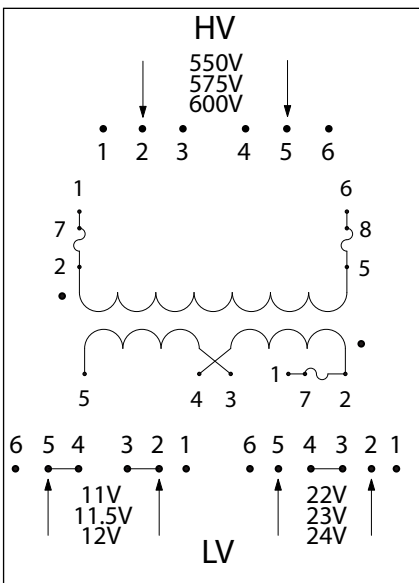

PH*** AR Schematic for 150VA to 500VA Units

High Voltage (HV) (Primary Volts)	Install Supplied Jumpers/ Links Between Terminals	Supply Lines Connect To	Install Fuse Clips To
600 575 550	None	2, 5	Unfused
600 575 550	None	1, 6	2-7, 5-8

Low Voltage (LV) (Secondary Volts)	Install Supplied Links Between Terminals	Load Lines Connect To	Install Fuse Clips To
12 11.5 11	4-5, 2-3	2, 5	Unfused
24 23 22	3-4	2, 5	Unfused
12 11.5 11	4-5, 2-3	1, 5	2-7
24 23 22	3-4	1, 5	2-7

HPS IMPERATOR - Wiring Schematic Drawings continued

Group C

SECTION 1

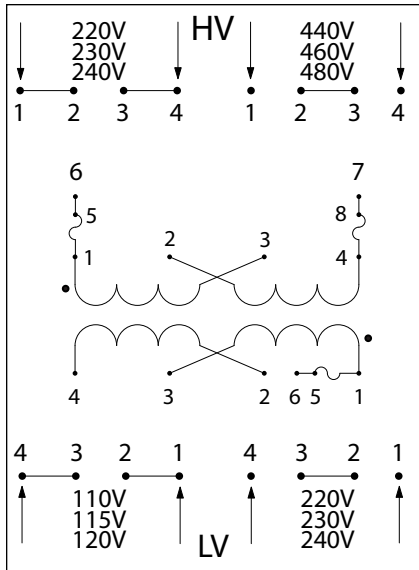

PH***MQMJ Schematic for 50, 75 and 100VA Units

High Voltage (HV) (Primary Volts)

240	230	220
480	460	440
240	230	220
480	460	440

Install Supplied Links Between Terminals

1-2, 3-4
2-3
1-2, 3-4
2-3

Supply Lines Connect To

1, 4
1, 4
6, 7
6, 7

Install Fuse Clips To

Unfused
Unfused
1-5, 4-8
1-5, 4-8

Low Voltage (LV) (Secondary Volts)

120	115	110
240	230	220
120	115	110
240	230	220

Install Supplied Links Between Terminals

3-4, 1-2
2-3
3-4, 1-2
2-3

Load Lines Connect To

1, 4
1, 4
4, 6
4, 6

Install Fuse Clips To

Unfused
Unfused
1-5
1-5

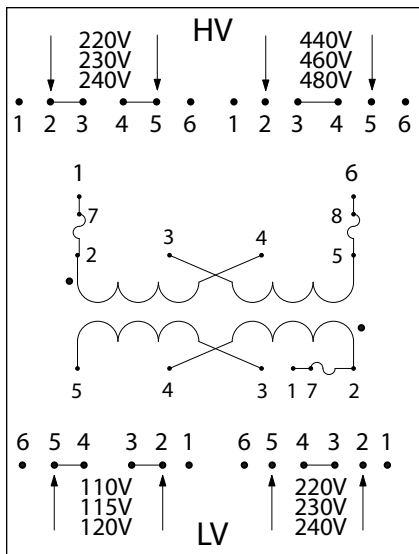

PH***MQMJ Schematic for 150VA to 1500VA Units

High Voltage (HV) (Primary Volts)

240	230	220
480	460	440
240	230	220
480	460	440

Install Supplied Links Between Terminals

2-3, 4-5
3-4
2-3, 4-5
3-4

Supply Lines Connect To

2, 5
2, 5
1, 6
1, 6

Install Fuse Clips To

Unfused
Unfused
2-7, 5-8
2-7, 5-8

Low Voltage (LV) (Secondary Volts)

120	115	110
240	230	220
120	115	110
240	230	220

Install Supplied Links Between Terminals

4-5, 2-3
3-4
4-5, 2-3
3-4

Load Lines Connect To

2, 5
2, 5
1, 5
1, 5

Install Fuse Clips To

Unfused
Unfused
2-7
2-7

HPS IMPERATOR - Wiring Schematic Drawings continued

Group D

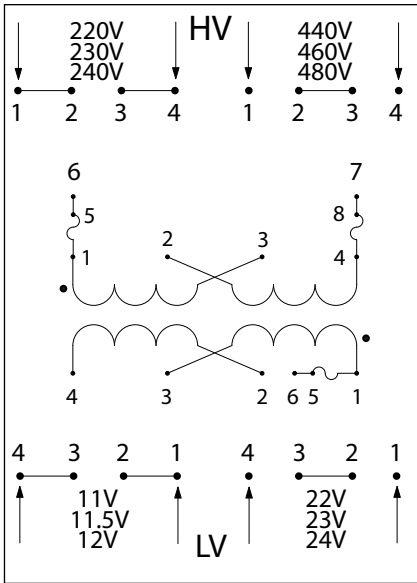

PH***QR Schematic for 50, 75 and 100VA Units

High Voltage (HV) (Primary Volts)

240	230	220
480	460	440
240	230	220
480	460	440

Install Supplied Links Between Terminals

1-2, 3-4
2-3
1-2, 3-4
2-3

Supply Lines Connect To

1, 4
1, 4
6, 7
6, 7

Install Fuse Clips To

Unfused
Unfused
1-5, 4-8
1-5, 4-8

Low Voltage (LV) (Secondary Volts)

12	11.5	11
24	23	22
12	11.5	11
24	23	22

Install Supplied Links Between Terminals

3-4, 1-2
2-3
3-4, 1-2
2-3

Load Lines Connect To

1, 4
1, 4
4, 6
4, 6

Install Fuse Clips To

Unfused
Unfused
1-5
1-5

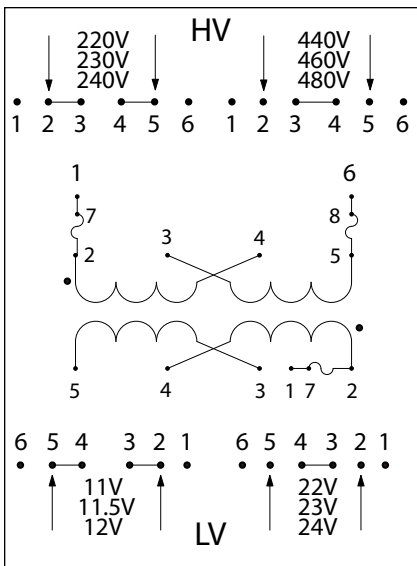

PH***QR Schematic for 150VA to 500VA Units

High Voltage (HV) (Primary Volts)

240	230	220
480	460	440
240	230	220
480	460	440

Install Supplied Links Between Terminals

2-3, 4-5
3-4
2-3, 4-5
3-4

Supply Lines Connect To

2, 5
2, 5
1, 6
1, 6

Install Fuse Clips To

Unfused
Unfused
2-7, 5-8
2-7, 5-8

Low Voltage (LV) (Secondary Volts)

12	11.5	11
24	23	22
12	11.5	11
24	23	22

Install Supplied Links Between Terminals

4-5, 2-3
3-4
4-5, 2-3
3-4

Load Lines Connect To

2, 5
2, 5
1, 5
1, 5

Install Fuse Clips To

Unfused
Unfused
2-7
2-7

HPS IMPERATOR - Wiring Schematic Drawings continued

Group E

SECTION 1

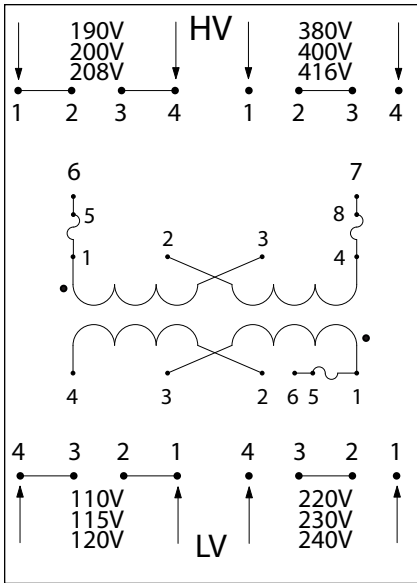

PH***SP Schematic for 50, 75 and 100VA Units

High Voltage (HV) (Primary Volts)

208	200	190
416	400	380
208	200	190
416	400	380

Install Supplied Links Between Terminals

1-2, 3-4
2-3
1-2, 3-4
2-3

Supply Lines Connect To

1, 4
1, 4
6, 7
6, 7

Install Fuse Clips To

Unfused
Unfused
1-5, 4-8
1-5, 4-8

Low Voltage (LV) (Secondary Volts)

120	115	110
240	230	220
120	115	110
240	230	220

Install Supplied Links Between Terminals

3-4, 1-2
2-3
3-4, 1-2
2-3

Load Lines Connect To

1, 4
1, 4
4, 6
4, 6

Install Fuse Clips To

Unfused
Unfused
1-5
1-5

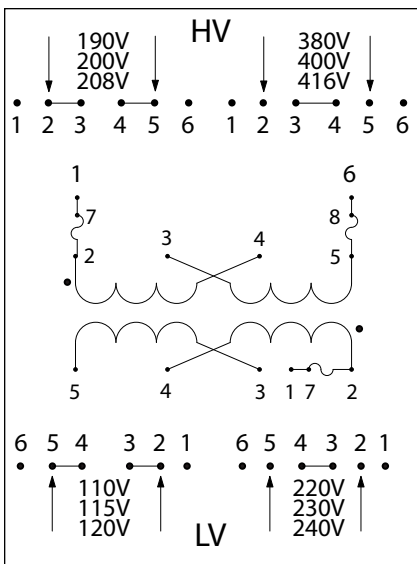

PH***SP Schematic for 150VA to 1000VA Units

High Voltage (HV) (Primary Volts)

208	200	190
416	400	380
208	200	190
416	400	380

Install Supplied Links Between Terminals

2-3, 4-5
3-4
2-3, 4-5
3-4

Supply Lines Connect To

2, 5
2, 5
1, 6
1, 6

Install Fuse Clips To

Unfused
Unfused
2-7, 5-8
2-7, 5-8

Low Voltage (LV) (Secondary Volts)

120	115	110
240	230	220
120	115	110
240	230	220

Install Supplied Links Between Terminals

4-5, 2-3
3-4
4-5, 2-3
3-4

Load Lines Connect To

2, 5
2, 5
1, 5
1, 5

Install Fuse Clips To

Unfused
Unfused
2-7
2-7

HPS IMPERATOR - Wiring Schematic Drawings continued

Group F

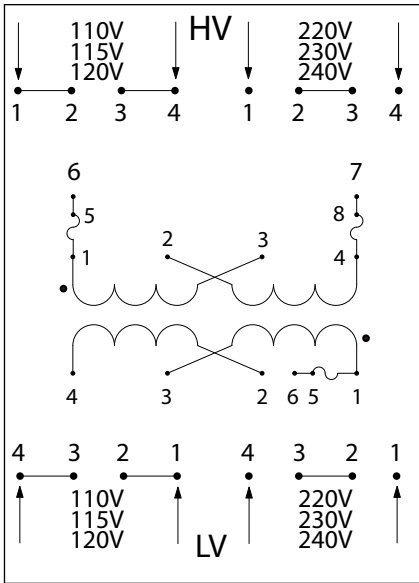

PH***PP Schematic for 50, 75 and 100VA Units

High Voltage (HV) (Primary Volts)

120	115	110
240	230	220
120	115	110
240	230	220

Install Supplied Links Between Terminals

1-2, 3-4
2-3
1-2, 3-4
2-3

Supply Lines Connect To

1, 4
1, 4
6, 7
6, 7

Install Fuse Clips To

Unfused
Unfused
1-5, 4-8
1-5, 4-8

Low Voltage (LV) (Secondary Volts)

120	115	110
240	230	220
120	115	110
240	230	220

Install Supplied Links Between Terminals

3-4, 1-2
2-3
3-4, 1-2
2-3

Load Lines Connect To

1, 4
1, 4
4, 6
4, 6

Install Fuse Clips To

Unfused
Unfused
1-5
1-5

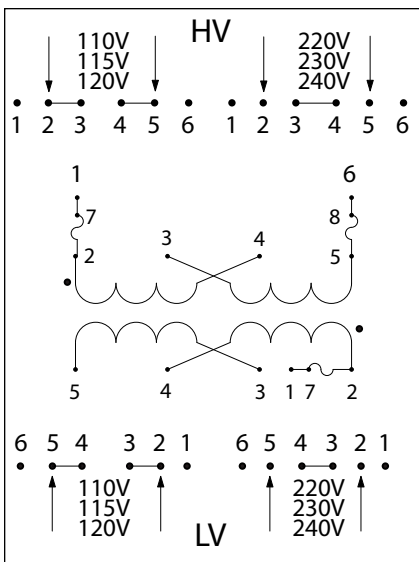

PH***PP Schematic for 150VA to 1500VA Units

High Voltage (HV) (Primary Volts)

120	115	110
240	230	220
120	115	110
240	230	220

Install Supplied Links Between Terminals

2-3, 4-5
3-4
2-3, 4-5
3-4

Supply Lines Connect To

2, 5
2, 5
1, 6
1, 6

Install Fuse Clips To

Unfused
Unfused
2-7, 5-8
2-7, 5-8

Low Voltage (LV) (Secondary Volts)

120	115	110
240	230	220
120	115	110
240	230	220

Install Supplied Links Between Terminals

4-5, 2-3
3-4
4-5, 2-3
3-4

Load Lines Connect To

2, 5
2, 5
1, 5
1, 5

Install Fuse Clips To

Unfused
Unfused
2-7
2-7

HPS IMPERATOR - Wiring Schematic Drawings continued

Group G

SECTION 1

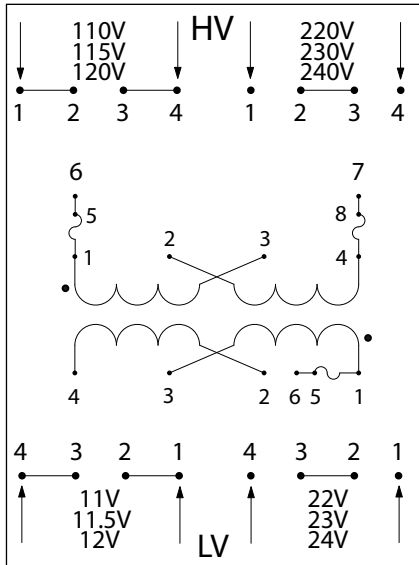

PH***PG Schematic for 50, 75 and 100VA Units

High Voltage (HV) (Primary Volts)	Install Supplied Links Between Terminals	Supply Lines Connect To	Install Fuse Clips To
120 115 110	1-2, 3-4	1, 4	Unfused
240 230 220	2-3	1, 4	Unfused
120 115 110	1-2, 3-4	6, 7	1-5, 4-8
240 230 220	2-3	6, 7	1-5, 4-8

Low Voltage (LV) (Secondary Volts)	Install Supplied Links Between Terminals	Load Lines Connect To	Install Fuse Clips To
12 11.5 11	3-4, 1-2	1, 4	Unfused
24 23 22	2-3	1, 4	Unfused
12 11.5 11	3-4, 1-2	4, 6	1-5
24 23 22	2-3	4, 6	1-5

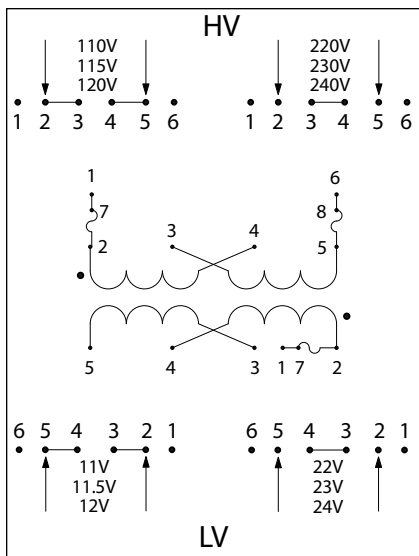

PH***PG Schematic for 150VA to 500VA Units

High Voltage (HV) (Primary Volts)	Install Supplied Links Between Terminals	Supply Lines Connect To	Install Fuse Clips To
120 115 110	2-3, 4-5	2, 5	Unfused
240 230 220	3-4	2, 5	Unfused
120 115 110	2-3, 4-5	1, 6	2-7, 5-8
240 230 220	3-4	1, 6	2-7, 5-8

Low Voltage (LV) (Secondary Volts)	Install Supplied Links Between Terminals	Load Lines Connect To	Install Fuse Clips To
12 11.5 11	4-5, 2-3	2, 5	Unfused
24 23 22	3-4	2, 5	Unfused
12 11.5 11	4-5, 2-3	1, 5	2-7
24 23 22	3-4	1, 5	2-7

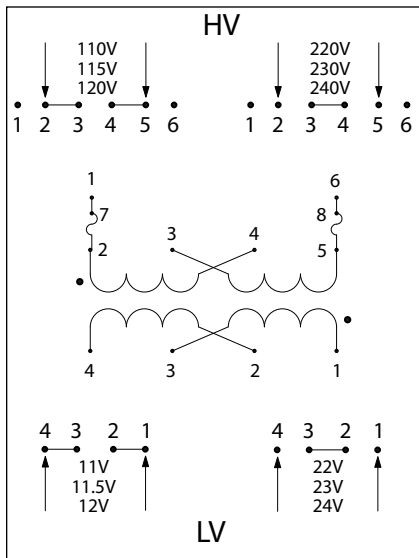

PH***PG Schematic for 750VA and 1000VA Units

High Voltage (HV) (Primary Volts)	Install Supplied Links Between Terminals	Supply Lines Connect To	Install Fuse Clips To
120 115 110	2-3, 4-5	2, 5	Unfused
240 230 220	3-4	2, 5	Unfused
120 115 110	2-3, 4-5	1, 6	2-7, 5-8
240 230 220	3-4	1, 6	2-7, 5-8

Low Voltage (LV) (Secondary Volts)	Install Supplied Links Between Terminals	Load Lines Connect To	Install Fuse Clips To
12 11.5 11	3-4, 1-2	1, 4	Unfused
24 23 22	2-3	1, 4	Unfused

Note: secondary fuse clips not available on PH750PG or PH1000PG.

HPS IMPERATOR - Wiring Schematic Drawings continued

Group H

PH***MBMH Schematic for 50 and 75VA Units

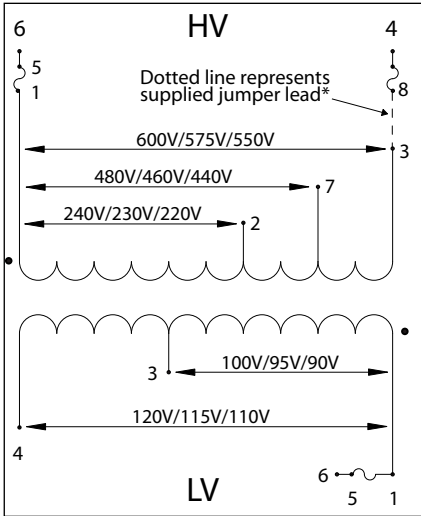

High Voltage (HV) (Primary Volts)	Install Supplied Jumpers Between Terminals	Supply Lines Connect To	Install Fuse Clips To
600 575 550	None	1, 3	Unfused
480 460 440	None	1, 7	Unfused
240 230 220	None	1, 2	Unfused
600 575 550	3-8	6, 4	1-5, 4-8
480 460 440	8-7	6, 4	1-5, 4-8
240 230 220	2-8	6, 4	1-5, 4-8

Low Voltage (LV) (Secondary Volts)	Install Supplied Jumpers/ Links Between Terminals	Load Lines Connect To	Install Fuse Clips To
120 115 110	None	1, 4	Unfused
100 95 90	None	1, 3	Unfused
120 115 110	None	4, 6	1-5
100 95 90	None	3, 6	1-5

*This primary fuse jumper is supplied with the primary fuse kit only.

PH***MBMH Schematic for 100VA to 1500VA Units

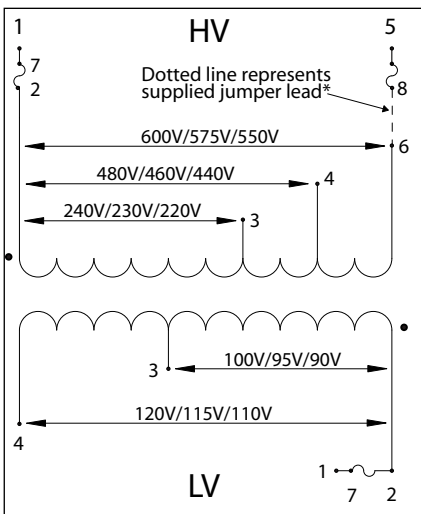

High Voltage (HV) (Primary Volts)	Install Supplied Jumpers Between Terminals	Supply Lines Connect To	Install Fuse Clips To
600 575 550	None	2, 6	Unfused
480 460 440	None	2, 4	Unfused
240 230 220	None	2, 3	Unfused
600 575 550	8-6	1, 5	2-7, 5-8
480 460 440	4-8	1, 5	2-7, 5-8
240 230 220	3-8	1, 5	2-7, 5-8

Low Voltage (LV) (Secondary Volts)	Install Supplied Jumpers/ Links Between Terminals	Load Lines Connect To	Install Fuse Clips To
120 115 110	None	2, 4	Unfused
100 95 90	None	2, 3	Unfused
120 115 110	None	1, 4	2-7
100 95 90	None	1, 3	2-7

*This primary fuse jumper is supplied with the primary fuse kit only.

HPS IMPERATOR - Wiring Schematic Drawings continued

Group I

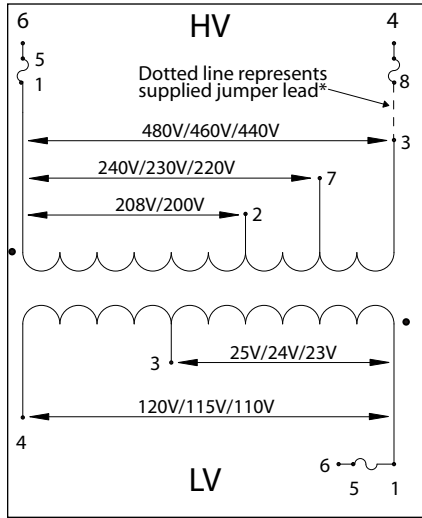

PH***MLI Schematic for 50, 75 and 100VA Units

High Voltage (HV) (Primary Volts)	Install Supplied Jumpers Between Terminals	Supply Lines Connect To	Install Fuse Clips To
480 460 440	None	1, 3	Unfused
240 230 220	None	1, 7	Unfused
208 200	None	1, 2	Unfused
480 460 440	3-8	6, 4	1-5, 4-8
240 230 220	8-7	6, 4	1-5, 4-8
208 200	2-8	6, 4	1-5, 4-8

Low Voltage (LV) (Secondary Volts)	Install Supplied Jumpers Between Terminals	Load Lines Connect To	Install Fuse Clips To
120 115 110	None	1, 4	Unfused
25 24 23	None	1, 3	Unfused
120 115 110	None	4, 6	1-5
25 24 23	None	3, 6	1-5

*This primary fuse jumper is supplied with the primary fuse kit only.

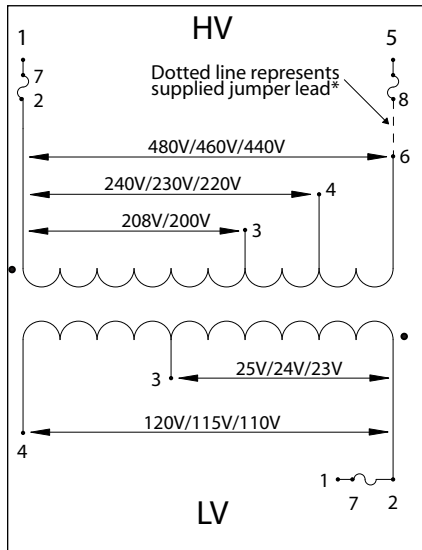

PH***MLI Schematic for 150VA to 500VA Units

High Voltage (HV) (Primary Volts)	Install Supplied Jumpers Between Terminals	Supply Lines Connect To	Install Fuse Clips To
480 460 440	None	2, 6	Unfused
240 230 220	None	2, 4	Unfused
208 200	None	2, 3	Unfused
480 460 440	8-6	1, 5	2-7, 5-8
240 230 220	4-8	1, 5	2-7, 5-8
208 200	3-8	1, 5	2-7, 5-8

Low Voltage (LV) (Secondary Volts)	Install Supplied Jumpers Between Terminals	Load Lines Connect To	Install Fuse Clips To
120 115 110	None	2, 4	Unfused
25 24 23	None	2, 3	Unfused
120 115 110	None	1, 4	2-7
25 24 23	None	1, 3	2-7

*This primary fuse jumper is supplied with the primary fuse kit only.

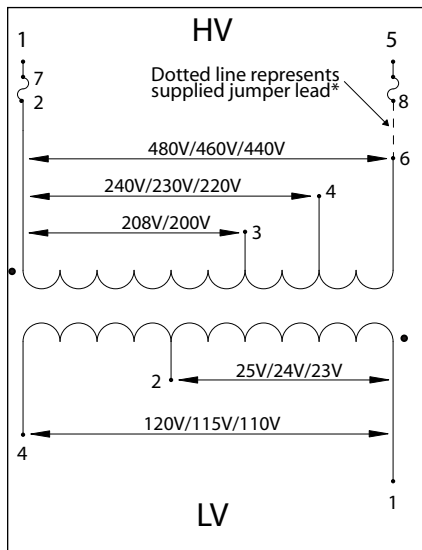

PH***MLI Schematic for 750VA and 1000VA Units

High Voltage (HV) (Primary Volts)	Install Supplied Jumpers Between Terminals	Supply Lines Connect To	Install Fuse Clips To
480 460 440	None	2, 6	Unfused
240 230 220	None	2, 4	Unfused
208 200	None	2, 3	Unfused
480 460 440	8-6	1, 5	2-7, 5-8
240 230 220	4-8	1, 5	2-7, 5-8
208 200	3-8	1, 5	2-7, 5-8

Low Voltage (LV) (Secondary Volts)	Install Supplied Jumpers Between Terminals	Load Lines Connect To	Install Fuse Clips To
120 115 110	None	1, 4	Unfused
25 24 23	None	1, 2	Unfused

Note: secondary fuse clips for 24V tap not available on the PH750MLI or PH1000MLI units.

*This primary fuse jumper is supplied with the primary fuse kit only.



HPS IMPERATOR - Wiring Schematic Drawings continued

Group J

PH***MEMX Schematic for 50, 75 and 100VA Units

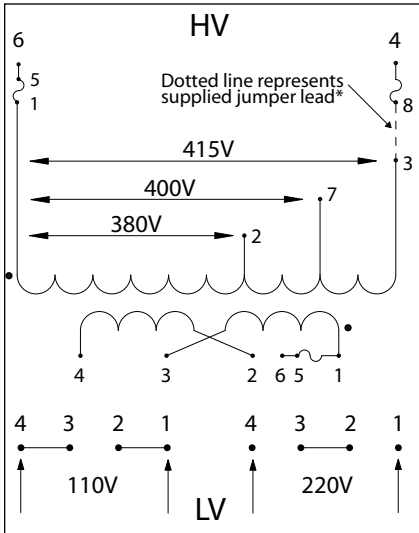

*This primary fuse jumper is supplied with the primary fuse kit only.

High Voltage (HV) (Primary Volts)	Install Supplied Jumpers Between Terminals	Supply Lines Connect To	Install Fuse Clips To
415	None	1, 3	Unfused
400	None	1, 7	Unfused
380	None	1, 2	Unfused
415	3-8	6, 4	1-5, 4-8
400	8-7	6, 4	1-5, 4-8
380	2-8	6, 4	1-5, 4-8

Low Voltage (LV) (Secondary Volts)	Install Supplied Links Between Terminals	Load Lines Connect To	Install Fuse Clips To
110	3-4, 1-2	1, 4	Unfused
220	2-3	1, 4	Unfused
110	3-4, 1-2	4, 6	1-5
220	2-3	4, 6	1-5

PH***MEMX Schematic for 150VA to 1000VA Units

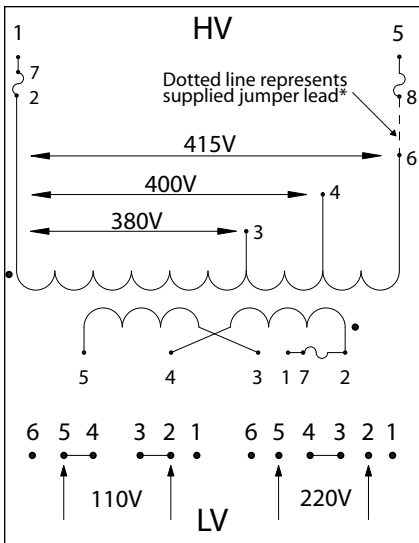

*This primary fuse jumper is supplied with the primary fuse kit only.

High Voltage (HV) (Primary Volts)	Install Supplied Jumpers Between Terminals	Supply Lines Connect To	Install Fuse Clips To
415	None	2, 6	Unfused
400	None	2, 4	Unfused
380	None	2, 3	Unfused
415	8-6	1, 5	2-7, 5-8
400	4-8	1, 5	2-7, 5-8
380	3-8	1, 5	2-7, 5-8

Low Voltage (LV) (Secondary Volts)	Install Supplied Links Between Terminals	Load Lines Connect To	Install Fuse Clips To
110	4-5, 2-3	2, 5	Unfused
220	3-4	2, 5	Unfused
110	4-5, 2-3	1, 5	2-7
220	3-4	1, 5	2-7

HPS IMPERATOR - Wiring Schematic Drawings continued

SECTION 1

Group K

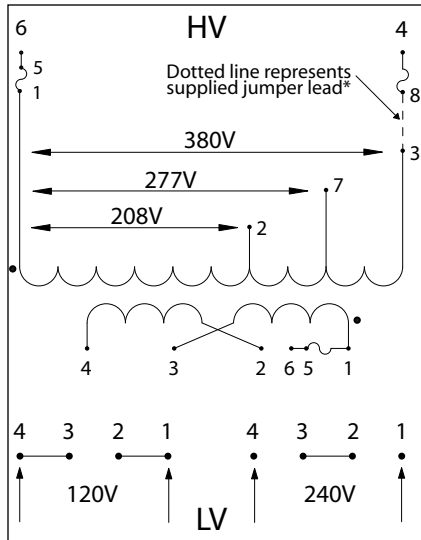

*This primary fuse jumper is supplied with the primary fuse kit only.

PH***MGJ Schematic for 50, 75 and 100VA Units

High Voltage (HV) (Primary Volts)	Install Supplied Jumpers Between Terminals	Supply Lines Connect To	Install Fuse Clips To
380	None	1, 3	Unfused
277	None	1, 7	Unfused
208	None	1, 2	Unfused
380	3-8	6, 4	1-5, 4-8
277	8-7	6, 4	1-5, 4-8
208	2-8	6, 4	1-5, 4-8

Low Voltage (LV) (Secondary Volts)	Install Supplied Links Between Terminals	Load Lines Connect To	Install Fuse Clips To
120	3-4, 1-2	1, 4	Unfused
240	2-3	1, 4	Unfused
120	3-4, 1-2	4, 6	1-5
240	2-3	4, 6	1-5

PH***MGJ Schematic for 150VA to 1000VA Units

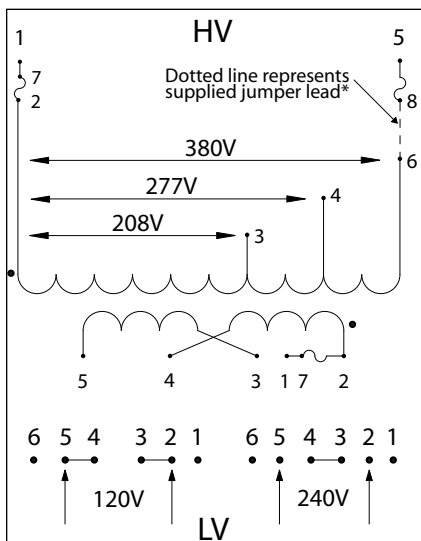

*This primary fuse jumper is supplied with the primary fuse kit only.

High Voltage (HV) (Primary Volts)	Install Supplied Jumpers Between Terminals	Supply Lines Connect To	Install Fuse Clips To
380	None	2, 6	Unfused
277	None	2, 4	Unfused
208	None	2, 3	Unfused
380	8-6	1, 5	2-7, 5-8
277	4-8	1, 5	2-7, 5-8
208	3-8	1, 5	2-7, 5-8

Low Voltage (LV) (Secondary Volts)	Install Supplied Links Between Terminals	Load Lines Connect To	Install Fuse Clips To
120	4-5, 2-3	2, 5	Unfused
240	3-4	2, 5	Unfused
120	4-5, 2-3	1, 5	2-7
240	3-4	1, 5	2-7

HPS Spartan and HPS Fusion - Wiring Schematic Drawings

Group A

SP*** ACP Schematic Connections for 600/480 to 120 X 240

FS*** ACP Schematic Connections for 600/480 to 120 X 240

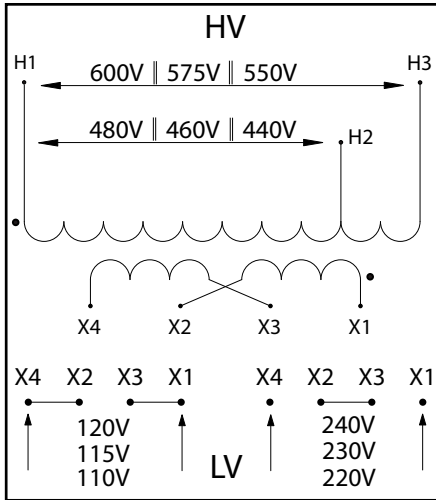

High Voltage (HV) (Primary Volts)

600	575	550
480	460	440

Install Supplied Jumpers Between Terminals

None
None

Supply Lines Connect To

H1, H3
H1, H2

Low Voltage (LV) (Secondary Volts)

120	115	110
240	230	220

Install Supplied Links Between Terminals

X1-X3, X2-X4
X2-X3

Load Lines Connect To

X1, X4
X1, X4

Group B

SP*** AR Schematic Connections for 600/480 to 12 X 24

FS*** AR Schematic Connections for 600/480 to 12 X 24

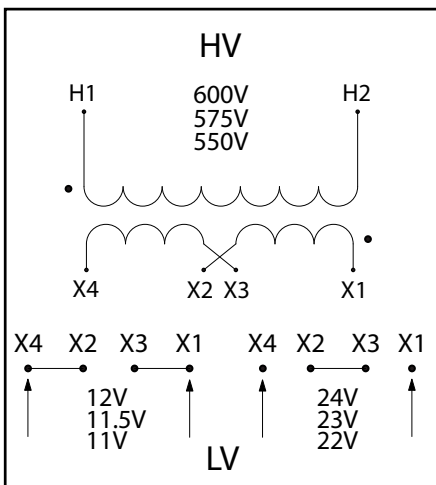

High Voltage (HV) (Primary Volts)

600	575	550
-----	-----	-----

Install Supplied Jumpers Between Terminals

None

Supply Lines Connect To

H1, H2

Low Voltage (LV) (Secondary Volts)

12	11.5	11
24	23	22

Install Supplied Links Between Terminals

X1-X3, X2-X4
X2-X3

Load Lines Connect To

X1, X4
X1, X4

HPS Fusion and HPS Spartan - Wiring Schematic Drawings continued

SECTION 1

Group C

SP***MQMJ Schematic Connections for 240 X 480 to 120 X 240

FS***MQMJ Schematic Connections for 240 X 480 to 120 X 240

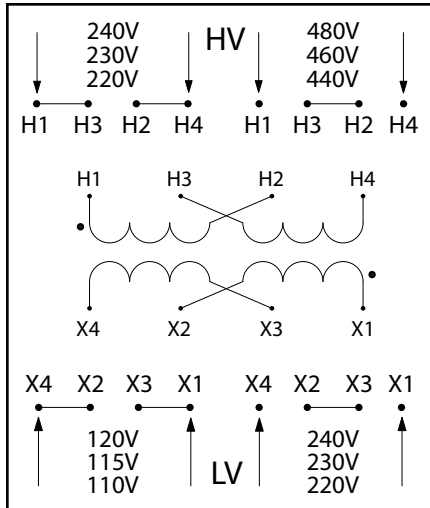

High Voltage (HV) (Primary Volts)

240	230	220
480	460	440

Install Supplied Jumpers Between Terminals

H1-H3, H2-H4
H2-H3

Supply Lines Connect To

H1, H4
H1, H4

Low Voltage (LV) (Secondary Volts)

120	115	110
240	230	220

Install Supplied Links Between Terminals

X1-X3, X2-X4
X2-X3

Load Lines Connect To

X1, X4
X1, X4

Group D

SP***QR Schematic Connections for 240 X 480 to 12 X 24

FS***QR Schematic Connections for 240 X 480 to 12 X 24

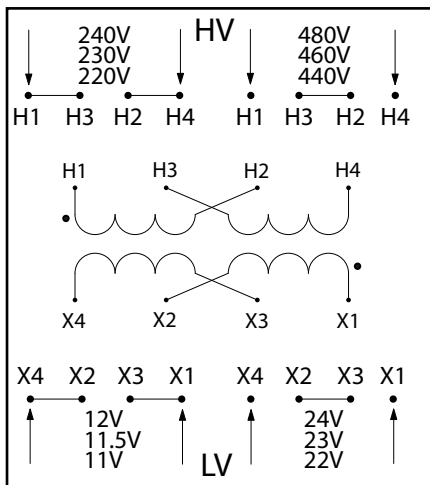

High Voltage (HV) (Primary Volts)

240	230	220
480	460	440

Install Supplied Jumpers Between Terminals

H1-H3, H2-H4
H2-H3

Supply Lines Connect To

H1, H4
H1, H4

Low Voltage (LV) (Secondary Volts)

12	11.5	11
24	23	22

Install Supplied Links Between Terminals

X1-X3, X2-X4
X2-X3

Load Lines Connect To

X1, X4
X1, X4

HPS Fusion and HPS Spartan - Wiring Schematic Drawings continued

Group E

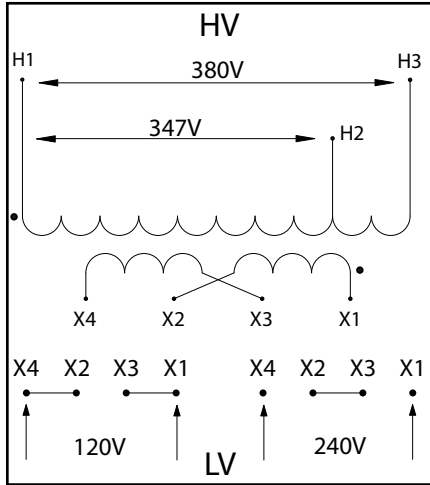

SP***KHP Schematic Connections for 380/347 to 120 X 240

FS***KHP Schematic Connections for 380/347 to 120 X 240

High Voltage (HV) (Primary Volts)	Install Supplied Jumpers Between Terminals	Supply Lines Connect To
380	None	H1, H3
347	None	H1, H2

Low Voltage (LV) (Secondary Volts)	Install Supplied Links Between Terminals	Load Lines Connect To
120	X1-X3, X2-X4	X1, X4
240	X2-X3	X1, X4

Group F

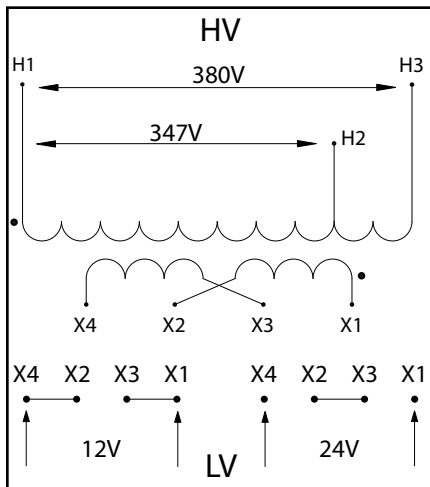

SP***KHR Schematic Connections for 380/347 to 12 X 24

FS***KHR Schematic Connections for 380/347 to 12 X 24

High Voltage (HV) (Primary Volts)	Install Supplied Jumpers Between Terminals	Supply Lines Connect To
380	None	H1, H3
347	None	H1, H2

Low Voltage (LV) (Secondary Volts)	Install Supplied Links Between Terminals	Load Lines Connect To
12	X1-X3, X2-X4	X1, X4
24	X2-X3	X1, X4

HPS Spartan and HPS Fusion - Wiring Schematic Drawings continued

SECTION 1

Group G

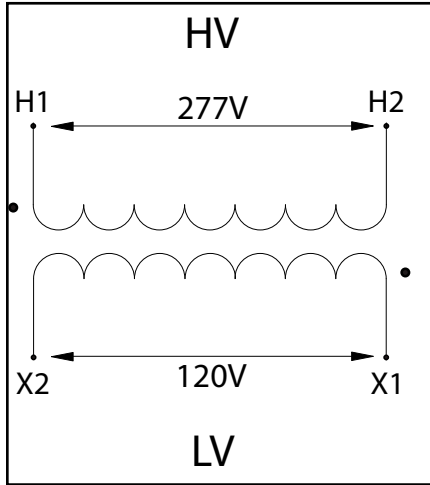

SP***NJ Schematic Connections for 277 to 120

FS***NJ Schematic Connections for 277 to 120

High Voltage (HV) (Primary Volts) 277	Install Supplied Jumpers Between Terminals None	Supply Lines Connect To H1, H2
Low Voltage (LV) (Secondary Volts) 120	Install Supplied Links Between Terminals None	Load Lines Connect To X1, X2

Group H

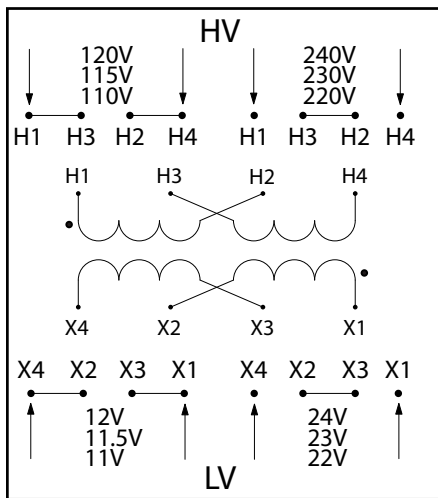

SP***PR Schematic Connections for 120 X 240 to 12 X 24

FS***PR Schematic Connections for 120 X 240 to 12 X 24

High Voltage (HV) (Primary Volts) 120 115 110 240 230 220	Install Supplied Jumpers Between Terminals H1-H3, H2-H4 H2-H3	Supply Lines Connect To H1, H4 H1, H4
Low Voltage (LV) (Secondary Volts) 12 11.5 11 24 23 22	Install Supplied Links Between Terminals X1-X3, X2-X4 X2-X3	Load Lines Connect To X1, X4 X1, X4

HPS Spartan and HPS Fusion - Wiring Schematic Drawings continued

Group I

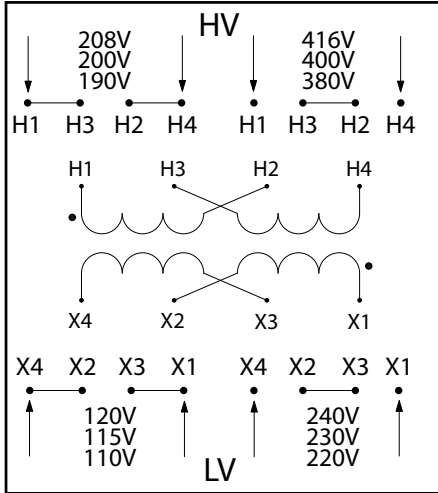

SP***SP Schematic Connections for 208 X 416 to 120 X 240

FS***SP Schematic Connections for 208 X 416 to 120 X 240

High Voltage (HV) (Primary Volts)

208	200	190
416	400	380

Install Supplied Jumpers Between Terminals

H1-H3, H2-H4
H2-H3

Supply Lines Connect To

H1, H4
H1, H4

Low Voltage (LV) (Secondary Volts)

120	115	110
240	230	220

Install Supplied Links Between Terminals

X1-X3, X2-X4
X2-X3

Load Lines Connect To

X1, X4
X1, X4

Group J

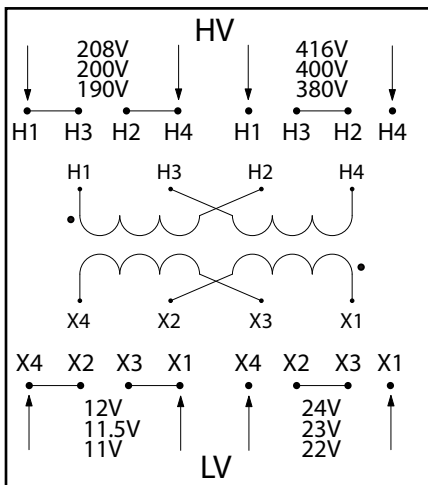

High Voltage (HV) (Primary Volts)

208	200	190
416	400	380

Install Supplied Jumpers Between Terminals

H1-H3, H2-H4
H2-H3

Supply Lines Connect To

H1, H4
H1, H4

Low Voltage (LV) (Secondary Volts)

12	11.5	11
24	23	22

Install Supplied Links Between Terminals

X1-X3, X2-X4
X2-X3

Load Lines Connect To

X1, X4
X1, X4





SECTION 2

HPS UNIVERSAL™ BUCK-BOOST TRANSFORMERS

Single and Three Phase Potted Buck-Boost Transformers

Buck-Boost Applications & Standard Specification.....	82
Selecting Buck-Boost Transformers	83
Single Phase Selection Tables	84
Three Phase Selection Tables	87
Single Phase Specification Tables	90
Three Phase Specification Tables	91
Single Phase Connection Diagrams	93
Three Phase Connection Diagrams	94
Three Phase Buck-Boost Explained	95

Why Use Buck-Boost Transformers?

The advantages of using a buck-boost transformer over an equivalent standard isolation transformer are:

Advantages

- 1) Used in a variety of applications
- 2) Inexpensive
- 3) Smaller and lighter
- 4) More efficient
- 5) 5-10 times increase in kVA



Disadvantages

- 1) No circuit isolation
- 2) Cannot create a neutral
- 3) KVA and voltages do not match what's on the nameplate kVA and voltages.

Buck-Boost Application

Buck-boost transformers offer an economical solution to the adjustment of line voltages that are slightly above or below normal. When a buck-boost transformer is connected as an autotransformer, only a portion of the load kVA is actually transformed. The majority of the load kVA is passed directly through to the source. For this reason a buck-boost transformer may be used to supply a much larger kVA load than is indicated on the nameplate.

Buck-boost transformers can be used to adjust **stable** voltages only.

BUCK-BOOST STANDARD SPECIFICATIONS

	50 to 1000 VA	1500 to 5000 VA
UL Listed	File: E50394	File: E50394
CSA Certified	File: LR3902	File: LR3902
Frequency	50/60 Hz	50/60 Hz
Insulation System	130°C (80°C rise)	180°C (115°C rise)
Standard Design	Single Phase, welded core construction made with high quality, high permeability silicon steel laminations. Computer designed coils, accurately wound from high quality copper magnetic wire.	Single Phase, welded core construction made with high quality, high permeability silicon steel laminations. Computer designed coils, accurately wound from high quality copper magnetic wire.
Encapsulation	All units from 50VA to 5kVA are encapsulated with electrical grade silica sand and resin compounds.	All units from 50VA to 5kVA are encapsulated with electrical grade silica sand and resin compounds.
Enclosure Type	Heavy Duty NEMA Type 3R (optional NEMA 4, 4X and 12 available)	Heavy Duty NEMA Type 3R (optional NEMA 4, 4X and 12 available)
Enclosure Finish	ANSI 61 Grey, UL50	ANSI 61 Grey, UL50
Termination	Front accessible separate high and low voltage lead wires or copper tabs.	Front accessible separate high and low voltage lead wires or copper tabs.
Conduit Knock-Outs	Side and rear standard on all units.	Side and rear standard on all units.
Mounting	Standard Wall Mounting.	Standard Wall Mounting.

Voltage Is the Key

Buck-boost transformers represent an economical way to both raise supply voltage caused by line drop or equipment demand on the distribution system, or lower voltage caused by increased system voltages due to supply line adjustments. Some loads including lighting and resistive loads require a stable supply to maintain performance. The detrimental effects of incorrect supply line voltage can cause equipment failure. Buck-boost transformers can correct line voltage within 5 to 25% of nominal.

Steps for Selecting Buck-Boost Transformers

The following information is required before selecting a buck-boost transformer:

- (1) Line Voltage - The voltage that you want to buck (decrease) or boost (increase). This can be determined by measuring the supply line voltage with a voltmeter.
- (2) Load Voltage - The voltage at which your equipment is designed to operate. This is listed on the nameplate of the load equipment.
- (3) Load kVA or Load Amps - You do not need to know both - one or the other is sufficient. This information usually can be found on the nameplate of the equipment that you want to operate. It is the sum of all the equipment that represents the load.
- (4) Frequency - The supply line frequency must be the same as the equipment to be operated - either 50 or 60 Hertz.
- (5) Phase - The supply line should be the same as the load - either single or three phase.

Four Steps to Select the Correct Buck-Boost Transformer

1. From the top row of each "Selection Chart", select a 'high voltage' and 'low voltage' combination that is the closest to matching the high voltage and low voltage correction that is required for your application.
2. Move down that column to the kVA or current rating equal to, or greater than, the rating required by the total load. It is not likely that the exact value of the load will be found, so go to the next higher rating.
3. From the far left column, select the corresponding catalog number of the exact buck-boost transformer required. Refer to specification tables for dimensional information.
4. Connect the transformer in accordance with the connection diagram referenced at the bottom of the same column where you selected your high voltage and low voltage combination. Connection diagrams are on pages 93 and 94 in this catalog section. They are also packaged with each transformer.



How to use the Selection Chart

1. From the top row of the “**Selection Chart**” locate the high and low voltage combination that is closest to the one you require.
2. Move down that column to the kVA or Ampere rating equal to or greater than the rating required by the load.
3. From the far left column, obtain the transformer catalog number.
4. For dimensional information refer to the specifications table (Group A) on page 90.
5. The corresponding connection diagram is indicated at the bottom of the Voltage / kVA column. See page 93 for the connection diagrams.

Single Phase - Group A Selection Chart

Catalog Number	Low Voltage High Voltage	96	100	100	105	110	110	115	115	120	120	200	208	220	220	240	240
		115	110	120	115	121	132	126	138	132	144	220	229	231	242	252	264
QC05ERCB	HV Amps	2.08	4.17	2.08	4.17	4.17	2.08	4.17	2.08	4.17	2.08	2.08	2.08	4.17	2.08	4.17	2.08
	KVA	.240	.458	.250	.480	.504	.275	.526	.288	.550	.300	.458	.477	.963	.504	1.05	.550
	LV Amps	2.50	4.58	2.50	4.58	4.58	2.50	4.58	2.50	4.58	2.50	2.29	2.29	4.38	2.29	4.38	2.29
QC10ERCB	HV Amps	4.17	8.33	4.17	8.33	8.33	4.17	8.33	4.17	8.33	4.17	4.17	4.17	8.33	4.17	8.33	4.17
	KVA	.480	.917	.500	.961	1.01	.550	1.05	.575	1.10	.600	.917	.953	1.92	1.01	2.10	1.10
	LV Amps	5.00	9.17	5.00	9.17	9.17	5.00	9.17	5.00	9.17	5.00	4.58	4.58	8.75	4.58	8.75	4.58
QC15ERCB	HV Amps	6.25	12.5	6.25	12.5	12.5	6.25	12.5	6.25	12.5	6.25	6.25	6.25	12.5	6.25	12.5	6.25
	KVA	.720	1.38	.750	1.44	1.51	.825	1.58	.863	1.65	.900	1.38	1.43	2.88	1.51	3.15	1.65
	LV Amps	7.50	13.8	7.50	13.8	13.8	7.50	13.8	7.50	13.8	7.50	6.88	6.88	13.1	6.88	13.1	6.88
QC20ERCB	HV Amps	8.33	16.7	8.33	16.7	16.7	8.33	16.7	8.33	16.7	8.33	8.33	8.33	16.7	8.33	16.7	8.33
	KVA	.960	1.83	1.00	1.92	2.02	1.10	2.11	1.15	2.20	1.20	1.83	1.91	3.85	2.02	4.20	2.20
	LV Amps	10.0	18.3	10.0	18.3	18.3	10.0	18.3	10.0	18.3	10.0	9.17	9.17	17.5	9.17	17.5	9.17
QC25ERCB	HV Amps	10.4	20.8	10.4	20.8	20.8	10.4	20.8	10.4	20.8	10.4	10.4	10.4	20.8	10.4	20.8	10.4
	KVA	1.20	2.29	1.25	2.40	2.52	1.37	2.63	1.44	2.75	1.50	2.29	2.38	4.81	2.52	5.25	2.75
	LV Amps	12.5	22.9	12.5	22.9	22.9	12.5	22.9	12.5	22.9	12.5	11.4	11.4	21.8	11.4	21.8	11.4
QC35ERCB	HV Amps	14.6	29.2	14.6	29.2	29.2	14.6	29.2	14.6	29.2	14.6	14.6	14.6	29.2	14.6	29.2	14.6
	KVA	1.68	3.21	1.75	3.36	3.53	1.92	3.68	2.01	3.85	2.10	3.21	3.34	6.74	3.53	7.35	3.85
	LV Amps	17.5	32.1	17.5	32.1	32.1	17.5	32.1	17.5	32.1	17.5	16.0	16.0	30.6	16.0	30.6	16.0
QC50ERCB	HV Amps	20.8	41.6	20.8	41.7	41.7	20.8	41.7	20.8	41.7	20.8	20.8	20.8	41.7	20.8	41.7	20.8
	KVA	2.39	4.58	2.50	4.80	5.04	2.75	5.26	2.87	5.50	3.00	4.58	4.77	9.62	5.04	10.5	5.50
	LV Amps	24.9	45.8	25.0	45.8	45.8	25.0	45.8	25.0	45.8	25.0	22.9	22.9	43.7	22.9	43.7	22.9
QC75ERCB	HV Amps	31.2	62.5	31.2	62.5	62.5	31.2	62.5	31.2	62.5	31.2	31.2	31.2	62.5	31.2	62.5	31.2
	KVA	3.60	6.87	3.75	7.20	7.56	4.12	7.89	4.31	8.25	4.50	6.87	7.15	14.4	7.56	15.7	8.25
	LV Amps	37.5	68.7	37.5	68.7	68.7	37.5	68.7	37.5	68.7	37.5	34.4	34.4	65.6	34.4	65.6	34.4
Q1C0ERCB	HV Amps	41.7	83.3	41.7	83.3	83.3	41.7	83.3	41.7	83.3	41.7	41.7	41.7	83.3	41.7	83.3	41.7
	KVA	4.80	9.17	5.00	9.60	10.1	5.50	10.5	5.75	11.0	6.00	9.17	9.53	19.2	10.1	21.0	11.0
	LV Amps	50.0	91.7	50.0	91.7	91.7	50.0	91.7	50.0	91.7	50.0	45.8	45.8	87.5	45.8	87.5	45.8
Q1C5ERCF	HV Amps	62.5	125	62.5	125	125	62.5	125	62.5	125	62.5	62.5	62.5	125	62.5	125	62.5
	KVA	7.20	13.7	7.50	14.4	15.1	8.25	15.8	8.62	16.5	9.00	13.7	14.3	28.9	15.1	31.5	16.5
	LV Amps	75.0	137	75.0	137	137	75.0	137	75.0	137	75.0	68.7	68.8	131	68.7	131	68.7
Q002ERCF	HV Amps	83.3	166	83.3	166	166	83.3	166	83.3	166	83.3	83.3	83.3	166	83.3	166	83.3
	KVA	9.58	18.3	10.0	19.2	20.1	11.0	21.0	11.5	22.0	12.0	18.3	19.0	38.5	20.1	42.0	22.0
	LV Amps	99.8	183	100	183	183	100	183	100	183	100	91.7	91.7	175	91.6	175	91.6
Q003ERCF	HV Amps	125	250	125	250	250	125	250	125	250	125	125	125	250	125	250	125
	KVA	14.4	27.5	15.0	28.8	30.2	16.5	31.5	17.2	33.0	18.0	27.5	28.6	57.7	30.2	63.0	33.0
	LV Amps	150	275	150	275	275	150	275	150	275	150	137	137	262	137	262	137
Q005ERCF	HV Amps	208	417	208	417	417	208	417	208	417	208	208	208	417	208	417	208
	KVA	24.0	45.8	25.0	48.0	50.4	27.5	52.7	28.7	55.0	30.0	45.8	47.7	96.3	50.4	105	55.0
	LV Amps	250	458	250	458	458	250	458	250	458	250	229	229	438	229	438	229
CONNECTION DIAGRAM		2	1	2	1	1	2	1	2	1	2	4	4	3	4	3	4

SECTION 2



How to use the Selection Chart

1. From the top row of the “**Selection Chart**” locate the high and low voltage combination that is closest to the one you require.
2. Move down that column to the kVA or Ampere rating equal to or greater than the rating required by the load.
3. From the far left column, obtain the transformer catalog number.
4. For dimensional information refer to the specifications table (Group B) on page 90.
5. The corresponding connection diagram is indicated at the bottom of the Voltage / kVA column. See page 93 for the connection diagrams.

Single Phase - Group B Selection Chart

Catalog Number	Low Voltage High Voltage	95 120	101 115	106 120	110 125	110 139	115 130	115 146	120 136	120 152	203 230	208 236	220 235	220 249	230 261	240 256	240 272
QC05ESCB	HV Amps	1.56	3.13	3.13	3.13	1.56	3.13	1.56	3.13	1.56	1.56	1.56	3.13	1.56	1.56	3.13	1.56
	KVA	.188	.359	.375	.390	.218	.407	.228	.425	.238	.359	.368	.733	.390	.407	.800	.425
	LV Amps	1.98	3.54	3.54	3.54	1.98	3.54	1.98	3.54	1.98	1.77	1.77	3.33	1.77	1.77	3.33	1.77
QC10ESCB	HV Amps	3.12	6.25	6.25	6.25	3.12	6.25	3.12	6.25	3.12	3.12	3.12	6.25	3.12	3.12	6.25	3.12
	KVA	.376	.718	.751	.779	.435	.815	.455	.850	.475	.719	.737	1.47	.779	.815	1.60	.850
	LV Amps	3.96	7.08	7.08	7.08	3.96	7.08	3.96	7.08	3.96	3.54	3.54	6.67	3.54	3.54	6.67	3.54
QC15ESCB	HV Amps	4.69	9.38	9.38	9.38	4.69	9.38	4.69	9.38	4.69	4.69	4.69	9.38	4.69	4.69	9.38	4.69
	KVA	.564	1.07	1.13	1.17	.653	1.22	.683	1.28	.713	1.08	1.10	2.20	1.17	1.22	2.40	1.28
	LV Amps	5.94	10.6	10.6	10.6	5.94	10.6	5.94	10.6	5.94	5.31	5.31	10.0	5.31	5.31	10.0	5.31
QC20ESCB	HV Amps	6.25	12.5	12.5	12.5	6.25	12.5	6.25	12.5	6.25	6.25	6.25	12.5	6.25	6.25	12.5	6.25
	KVA	.752	1.43	1.50	1.56	0.871	1.63	0.91	1.70	.950	1.44	1.47	2.93	1.56	1.63	3.20	1.70
	LV Amps	7.92	14.2	14.2	14.2	7.92	14.2	7.92	14.2	7.92	7.08	7.08	13.3	7.08	7.08	13.3	7.08
QC25ESCB	HV Amps	7.81	15.6	15.6	15.6	7.81	15.6	7.81	15.6	7.81	7.81	7.81	15.6	7.81	7.81	15.6	7.81
	KVA	0.94	1.80	1.87	1.95	1.09	2.04	1.14	2.12	1.19	1.80	1.84	3.67	1.95	2.04	4.00	2.12
	LV Amps	9.90	17.7	17.7	17.7	9.87	17.7	9.90	17.7	9.90	8.85	8.85	16.7	8.85	8.85	16.7	8.85
QC35ESCB	HV Amps	10.9	21.9	21.9	21.9	10.9	21.9	10.9	21.9	10.9	10.9	10.9	21.9	10.9	10.9	21.9	10.9
	KVA	1.31	2.51	2.63	2.73	1.52	2.85	1.59	2.98	1.66	2.51	2.58	5.13	2.73	2.85	5.60	2.98
	LV Amps	13.9	24.8	24.8	24.8	13.9	24.8	13.9	24.8	13.9	12.4	12.4	23.3	12.4	12.4	23.3	12.4
QC50ESCB	HV Amps	15.6	31.2	31.2	31.2	15.6	31.2	15.6	31.2	15.6	15.6	15.6	31.2	15.6	15.6	31.2	15.6
	KVA	1.88	3.59	3.75	3.90	2.18	4.07	2.28	4.25	2.37	3.59	3.68	7.33	3.90	4.07	8.00	4.25
	LV Amps	19.8	35.4	35.4	35.4	19.8	35.4	19.8	35.4	19.8	17.7	17.7	33.3	17.7	17.7	33.3	17.7
QC75ESCB	HV Amps	23.4	46.8	46.8	46.9	23.4	46.9	23.4	46.9	23.4	23.4	23.4	46.9	23.4	23.4	46.9	23.4
	KVA	2.82	5.39	5.63	5.84	3.27	6.10	3.41	6.37	3.56	5.39	5.53	11.0	5.84	6.11	12.0	6.37
	LV Amps	29.7	53.1	53.1	53.1	29.7	53.1	29.7	53.1	29.7	26.6	26.6	50.0	26.6	26.6	50.0	26.6
Q1C0ESCB	HV Amps	31.2	62.5	62.5	62.5	31.2	62.5	31.2	62.5	31.2	31.2	31.2	62.5	31.2	31.2	62.5	31.2
	KVA	3.76	7.18	7.50	7.79	4.35	8.15	4.55	8.50	4.75	7.19	7.37	14.7	7.79	8.15	16.0	8.50
	LV Amps	39.6	70.8	70.8	70.8	39.6	70.8	39.6	70.8	39.6	35.4	35.4	66.7	35.4	35.4	66.7	35.4
Q1C5ESCF	HV Amps	46.9	93.7	93.7	93.7	46.9	93.7	46.9	93.7	46.9	46.9	46.8	93.7	46.9	46.9	93.7	46.9
	KVA	5.64	10.8	11.2	11.7	6.53	12.2	6.83	12.7	7.12	10.8	11.0	22.0	11.7	12.2	24.0	12.7
	LV Amps	59.4	106	106	106	59.4	106	59.4	106	59.4	53.1	53.1	100	53.1	53.1	100	53.1
Q002ESCF	HV Amps	62.5	125	125	125	62.5	125	62.5	125	62.5	62.5	62.5	125	62.5	62.5	125	62.5
	KVA	7.50	14.4	15.0	15.6	8.71	16.3	9.10	17.0	9.50	14.4	14.7	29.3	15.6	16.3	32.0	17.0
	LV Amps	79.1	142	142	142	79.2	142	79.2	142	79.2	70.8	70.8	133	70.8	70.8	133	70.8
Q003ESCF	HV Amps	93.7	187	187	187	93.7	187	93.7	187	93.7	93.7	93.7	187	93.7	93.7	187	93.7
	KVA	11.3	21.5	22.5	23.4	13.0	24.4	13.6	25.5	14.2	21.6	22.1	44.0	23.4	24.4	48.0	25.5
	LV Amps	119	212	212	212	119	212	119	212	119	106	106	200	106	106	200	106
Q005ESCF	HV Amps	156	312	312	312	156	312	156	312	156	156	156	312	156	156	313	156
	KVA	18.8	35.9	37.5	39.0	21.8	40.7	22.8	42.5	23.8	35.9	36.8	73.3	39.0	40.7	80.0	42.5
	LV Amps	198	354	354	354	198	354	198	354	198	177	177	333	177	177	333	177
CONNECTION DIAGRAM		2	1	1	1	2	1	2	1	2	4	4	3	4	4	3	4



How to use the Selection Chart

1. From the top row of the “**Selection Chart**” locate the high and low voltage combination that is closest to the one you require.
2. Move down that column to the kVA or Ampere rating equal to or greater than the rating required by the load.
3. From the far left column, obtain the transformer catalog number.
4. For dimensional information refer to the specifications table (Group C) on page 91.
5. The corresponding connection diagram is indicated at the bottom of the Voltage / kVA column. See page 93 for the connection diagrams.

Single Phase - Group C Selection Chart

Catalog Number	Low Voltage High Voltage	200	208	220	230	240	380	416	430	435	436	440	440	450	456	460	480
		220	229	242	276	264	418	458	473	457	480	462	484	473	479	483	504
QC05DTCB	HV Amps	2.08	2.08	2.08	1.04	2.08	1.04	1.04	1.04	2.08	1.04	2.08	1.04	2.08	2.08	2.08	2.08
	KVA	0.46	0.48	0.50	0.29	0.55	0.44	0.48	0.49	0.95	0.50	0.96	0.50	0.98	1.00	1.01	1.05
	LV Amps	2.29	2.29	2.29	1.25	2.29	1.15	1.15	1.15	2.19	1.15	2.19	1.15	2.19	2.19	2.19	2.19
QC10DTCB	HV Amps	4.17	4.17	4.17	2.08	4.17	2.08	2.08	2.08	4.17	2.08	4.17	2.08	4.17	4.17	4.17	4.17
	KVA	0.92	0.95	1.01	0.58	1.10	0.87	0.95	0.99	1.90	1.00	1.93	1.01	1.97	2.00	2.01	2.10
	LV Amps	4.58	4.58	4.58	2.50	4.58	2.29	2.29	2.29	4.38	2.29	4.38	2.29	4.38	4.38	4.38	4.38
QC15DTCB	HV Amps	6.25	6.25	6.25	3.13	6.25	3.13	3.13	3.13	6.25	3.13	6.25	3.13	6.25	6.25	6.25	6.25
	KVA	1.38	1.43	1.51	0.86	1.65	1.31	1.43	1.48	2.85	1.50	2.89	1.51	2.95	2.99	3.02	3.15
	LV Amps	6.88	6.88	6.88	3.75	6.88	3.44	3.44	3.44	6.56	3.44	6.56	3.44	6.56	6.56	6.56	6.56
QC20DTCB	HV Amps	8.33	8.33	8.33	4.17	8.33	4.17	4.17	4.17	8.33	4.17	8.33	4.17	8.33	8.33	8.33	8.33
	KVA	1.83	1.91	2.02	1.15	2.20	1.74	1.91	1.97	3.81	2.00	3.85	2.02	3.94	3.99	4.03	4.20
	LV Amps	9.17	9.17	9.17	5.00	9.17	4.58	4.58	4.58	8.75	4.58	8.75	4.58	8.75	8.75	8.75	8.75
QC25DTCB	HV Amps	10.4	10.4	10.4	5.21	10.4	5.21	5.21	5.21	10.4	5.21	10.4	5.21	10.4	10.4	10.4	10.4
	KVA	2.29	2.38	2.52	1.44	2.75	2.18	2.38	2.46	4.76	2.50	4.81	2.52	4.92	4.99	5.03	5.25
	LV Amps	11.5	11.5	11.5	6.3	11.5	5.73	5.73	5.73	10.9	5.73	10.9	5.73	10.9	10.9	10.9	10.9
QC35DTCB	HV Amps	14.6	14.6	14.6	7.3	14.6	7.3	7.3	7.3	14.6	7.3	14.6	7.3	14.6	14.6	14.6	14.6
	KVA	3.21	3.34	3.53	2.01	3.85	3.05	3.34	3.45	6.61	3.50	6.74	3.53	6.89	6.98	7.0	7.4
	LV Amps	16.0	16.0	16.0	8.8	16.0	8.0	8.0	8.0	15.3	8.0	15.3	8.0	15.3	15.3	15.3	15.3
QC50DTCB	HV Amps	20.8	20.8	20.8	10.4	20.8	10.4	10.4	10.4	20.8	10.4	20.8	10.4	20.8	20.8	20.8	20.8
	KVA	4.58	4.77	5.04	2.88	5.5	4.35	4.77	4.93	9.52	5.00	9.63	5.04	9.84	9.98	10.1	10.5
	LV Amps	22.9	22.9	22.9	12.5	22.9	11.5	11.5	11.5	21.9	11.5	21.9	11.5	21.9	21.9	21.9	21.9
QC75DTCB	HV Amps	31.3	31.3	31.3	15.6	31.3	15.6	15.6	15.6	31.3	15.6	31.3	15.6	31.3	31.3	31.3	31.3
	KVA	6.88	7.15	7.56	4.31	8.25	6.53	7.15	7.39	14.3	7.49	14.4	7.56	14.8	15.0	15.1	15.8
	LV Amps	34.4	34.4	34.4	18.8	34.4	17.2	17.2	17.2	32.8	17.2	32.8	17.2	32.8	32.8	32.8	32.8
Q1C0DTCB	HV Amps	41.7	41.7	41.7	20.8	41.7	20.8	20.8	20.8	41.7	20.8	41.7	20.8	41.7	41.7	41.7	41.7
	KVA	9.17	9.53	10.1	5.75	11	8.71	9.53	9.85	19.0	9.99	19.3	10.1	19.7	20.0	20.1	21.0
	LV Amps	45.8	45.8	45.8	25.0	45.8	22.9	22.9	22.9	43.8	22.9	43.8	22.9	43.8	43.8	43.8	43.8
Q1C5DTCF	HV Amps	62.5	62.5	62.5	31.3	62.5	31.3	31.3	31.3	62.5	31.3	62.5	31.3	62.5	62.5	62.5	62.5
	KVA	13.8	14.3	15.1	8.6	16.5	13.1	14.3	14.8	28.5	15.0	28.9	15.1	29.5	29.9	30.2	31.5
	LV Amps	68.8	68.8	68.8	37.5	68.8	34.4	34.4	34.4	65.6	34.4	65.6	34.4	65.6	65.6	65.6	65.6
Q002DTCF	HV Amps	83.3	83.3	83.3	41.7	83.3	41.7	41.7	41.7	83.3	41.7	83.3	41.7	83.3	83.3	83.3	83.3
	KVA	18.3	19.1	20.2	11.5	22.0	17.4	19.1	19.7	38.1	20.0	38.5	20.2	39.4	39.9	40.3	42.0
	LV Amps	91.7	91.7	91.7	50.0	91.7	45.8	45.8	45.8	87.5	45.8	87.5	45.8	87.5	87.5	87.5	87.5
Q003DTCF	HV Amps	125	125	125	62.5	125	62.5	62.5	62.5	125	62.5	125	62.5	125	125	125	125
	KVA	27.5	28.6	30.3	17.3	33	26.1	28.6	29.6	57.1	30.0	57.8	30.3	59.1	59.9	60.4	63.0
	LV Amps	138	138	138	75	138	68.8	68.8	68.8	131	68.8	131	68.8	131	131	131	131
Q005DTCF	HV Amps	208	208	208	104	208	104	104	104	208	104	208	104	208	208	208	208
	KVA	45.8	47.7	50.4	28.8	55.0	43.5	47.7	49.3	95.2	50.0	96.3	50.4	98.4	99.8	101	105
	LV Amps	229	229	229	125	229	115	115	115	219	115	219	115	219	219	219	219
CONNECTION DIAGRAM		1	1	1	2	1	4	4	4	3	4	3	4	3	3	3	3

SECTION 2



How to use the Selection Chart

1. From the top row of the “**Selection Chart**” locate the high and low voltage combination that is closest to the one you require.
2. Determine the quantity you required.
3. The corresponding connection diagram is indicated at the top of the Voltage / kVA column. See page 94 for the connection diagrams.
4. Move down that column to the kVA or Ampere rating equal to or greater than the rating required by the load.
5. From the far left column, obtain the transformer catalog number.
6. For dimensional information refer to the specifications table (Group A) on page 91.

Three Phase - Group A Selection Chart

Catalog Number	Low Voltage		189	198	208	208	220	227	228	232	240	189	199	208	379	416	416
	High Voltage		208	208	218	229	242	250	239	255	264	109	115	120	219	240	240
QUANTITY REQUIRED			2	2	2	2	2	2	2	2	2	3	3	3	3	3	3
CONNECTION DIAGRAM <small>(Refer to Page 94)</small>			7	8	8	7	7	7	8	7	7	10	9	10	12	11	12
Three Phase Connection Style			Delta Connected									Wye Connected					
QC05ERCB	HV Amps	KVA	2.08	4.17	4.17	2.08	2.08	2.08	4.17	2.08	2.08	4.17	2.08	4.17	2.08	4.17	2.08
	KVA		0.76	1.51	1.58	0.83	0.88	0.91	1.73	0.93	0.96	1.50	0.86	1.65	1.51	3.15	1.65
QC10ERCB	HV Amps	KVA	4.17	8.33	8.33	4.17	4.17	4.17	8.33	4.17	4.17	8.33	4.17	8.33	4.17	8.33	4.17
	KVA		1.51	3.01	3.16	1.66	1.75	1.81	3.46	1.85	1.91	3.00	1.73	3.30	3.01	6.30	3.30
QC15ERCB	HV Amps	KVA	6.25	12.50	12.50	6.25	6.25	6.25	12.50	6.25	6.25	12.5	6.25	12.5	6.25	12.50	6.25
	KVA		2.26	4.51	4.73	2.48	2.62	2.71	5.19	2.77	2.86	4.50	2.59	4.95	4.52	9.45	4.95
QC20ERCB	HV Amps	KVA	8.33	16.70	16.70	8.33	8.33	8.33	16.70	8.33	8.33	16.7	8.33	16.7	8.33	16.70	8.33
	KVA		3.01	6.01	6.31	3.31	3.50	3.61	6.92	3.69	3.82	6.00	3.45	6.60	6.03	12.6	6.60
QC25ERCB	HV Amps	KVA	10.4	20.8	20.8	10.4	10.4	10.4	20.8	10.4	10.4	20.8	10.4	20.8	10.4	20.8	10.4
	KVA		3.76	7.51	7.89	4.13	4.37	4.51	8.64	4.61	4.77	7.50	4.31	8.25	7.53	15.75	8.25
QC35ERCB	HV Amps	KVA	14.6	29.2	29.2	14.6	14.6	14.6	29.2	14.6	14.6	29.2	14.6	29.2	14.6	29.2	14.6
	KVA		5.26	10.50	11.00	5.78	6.12	6.31	12.10	6.45	6.67	10.50	6.04	11.55	10.54	22.05	11.60
QC50ERCB	HV Amps	KVA	20.8	41.7	41.7	20.8	20.8	20.8	41.7	20.8	20.8	41.7	20.8	41.7	20.8	41.7	20.8
	KVA		7.51	15.00	15.80	8.26	8.74	9.02	17.30	9.21	9.53	15.0	8.60	16.5	15.1	31.5	16.5
QC75ERCB	HV Amps	KVA	31.3	62.5	62.5	31.3	31.3	31.3	62.5	31.3	31.3	62.5	31.3	62.5	31.3	62.5	31.3
	KVA		11.3	22.5	23.7	12.4	13.1	13.5	25.9	13.8	14.3	22.5	12.9	24.8	22.6	47.3	24.8
Q1C0ERCB	HV Amps	KVA	41.7	83.3	83.3	41.7	41.7	41.7	83.3	41.7	41.7	83.3	41.7	83.3	41.7	83.3	41.7
	KVA		15.0	30.0	31.5	16.5	17.5	18.0	34.6	18.4	19.1	30.0	17.3	33.0	30.1	63.0	33.0
Q1C5ERCF	HV Amps	KVA	62.5	125.0	125.0	62.5	62.5	62.5	125.0	62.5	62.5	125	62.5	125	62.5	125.0	62.5
	KVA		22.5	45.0	47.3	24.8	26.2	27.0	51.8	27.6	28.6	45.0	25.9	49.5	45.2	94.5	49.5
Q002ERCF	HV Amps	KVA	83.3	167.0	167.0	83.3	83.3	83.3	167.0	83.3	83.3	167	83.3	167	83.3	167.0	83.3
	KVA		30.0	60.0	63.1	33.0	34.9	36.1	69.1	36.8	38.1	60.0	34.5	66.0	60.3	126	66.0
Q003ERCF	HV Amps	KVA	125	250	250	125	125	125	250	125	125	250	125	250	125	250	125
	KVA		45.0	90.0	94.6	49.5	52.4	54.1	103.7	55.3	57.2	90.0	51.8	99.0	90.4	189	99.0
Q005ERCF	HV Amps	KVA	208	417	417	208	208	208	417	208	208	417	208	417	208	417	208
	KVA		75.0	150.0	157.6	82.6	87.3	90.1	172.8	92.1	95.3	150	86.3	165	151	315	165
			229	438	438	229	229	229	438	229	229	458	250	458	229	438	229



How to use the Selection Chart

1. From the top row of the “**Selection Chart**” locate the high and low voltage combination that is closest to the one you require.
2. Determine the quantity you required.
3. The corresponding connection diagram is indicated at the top of the Voltage / kVA column. See page 94 for the connection diagrams.
4. Move down that column to the kVA or Ampere rating equal to or greater than the rating required by the load.
5. From the far left column, obtain the transformer catalog number.
6. For dimensional information refer to the specifications table (Group B) on page 92.

Three Phase - Group B Selection Chart

Catalog Number	Low Voltage		184	195	208	208	225	230	234	234	240	240	184	416	379	416	416
	High Voltage		209	208	222	236	240	245	250	265	272	256	106	240	219	240	240
QUANTITY REQUIRED			2	2	2	2	2	2	2	2	2	3	3	3	3	3	
CONNECTION DIAGRAM <small>(Refer to Page 94)</small>			7	8	8	7	8	8	8	7	7	8	10	10	12	11	12
Three Phase Connection Style			Delta Connected									Wye Connected					
QC05ESCB	HV Amps	KVA	1.56	3.13	3.13	1.56	3.13	3.13	3.13	1.56	1.56	3.13	3.13	3.13	1.56	3.13	1.56
	LV Amps		0.57	1.13	1.21	0.64	1.30	1.33	1.36	0.72	0.74	1.39	1.13	1.28	1.17	2.40	1.28
QC10ESCB	HV Amps	KVA	1.77	3.33	3.33	1.77	3.33	3.33	3.33	1.77	1.77	3.33	3.54	3.54	1.77	3.33	1.77
	LV Amps		3.13	6.25	6.25	3.13	6.25	6.25	6.25	3.13	3.13	6.25	6.25	6.25	3.13	6.25	3.13
QC15ESCB	HV Amps	KVA	1.13	2.26	2.41	1.28	2.60	2.66	2.71	1.44	1.48	2.78	2.25	2.55	2.33	4.80	2.55
	LV Amps		3.54	6.67	6.67	3.54	6.67	6.67	6.67	3.54	3.54	6.67	7.08	7.08	3.54	6.67	3.54
QC20ESCB	HV Amps	KVA	4.69	9.38	9.38	4.69	9.38	9.38	9.38	4.69	4.69	9.38	9.38	9.38	4.69	9.4	4.69
	LV Amps		1.70	3.38	3.61	1.92	3.90	3.99	4.06	2.16	2.21	4.16	3.38	3.83	3.50	7.20	3.83
QC25ESCB	HV Amps	KVA	5.31	10.00	10.00	5.31	10.00	10.00	10.00	5.31	5.31	10.00	10.6	10.6	5.31	10.0	5.31
	LV Amps		6.25	12.50	12.50	6.25	12.50	12.50	12.50	6.25	6.25	12.50	12.5	12.5	6.25	12.50	6.25
QC35ESCB	HV Amps	KVA	2.26	4.51	4.81	2.56	5.20	5.32	5.41	2.88	2.94	5.55	4.50	5.10	4.67	9.60	5.10
	LV Amps		7.81	15.60	15.60	7.80	15.60	15.60	15.60	7.81	7.81	15.60	15.6	15.6	7.81	15.6	7.81
QC50ESCB	HV Amps	KVA	2.83	5.63	6.01	3.19	6.50	6.64	6.76	3.59	3.69	6.93	5.63	6.38	5.84	12.0	6.38
	LV Amps		8.85	16.70	16.70	8.90	16.70	16.70	16.70	8.85	8.85	16.70	17.7	17.7	8.85	16.7	8.85
QC75ESCB	HV Amps	KVA	10.9	21.9	21.9	10.9	21.9	21.9	21.9	10.9	10.9	21.9	21.9	21.9	10.9	21.9	10.9
	LV Amps		3.96	7.89	8.41	4.47	9.10	9.30	9.46	5.03	5.16	9.70	7.88	8.93	8.17	16.8	8.93
QC100ESCB	HV Amps	KVA	12.4	23.3	23.3	12.4	23.3	23.3	23.3	12.4	12.4	23.3	24.8	24.8	12.4	23.3	12.4
	LV Amps		15.6	31.3	31.3	15.6	31.3	31.3	31.3	15.6	15.6	31.3	31.3	31.3	15.6	31.3	15.6
QC150ESCB	HV Amps	KVA	5.65	11.30	12.00	6.38	13.00	13.30	13.50	7.18	7.37	13.90	11.3	12.8	11.7	24.0	12.8
	LV Amps		17.7	33.3	33.3	17.7	33.3	33.3	33.3	17.7	17.7	33.3	35.4	35.4	17.7	33.3	17.7
QC200ESCB	HV Amps	KVA	23.4	46.9	46.9	23.4	46.9	46.9	46.9	23.4	23.4	46.9	46.9	46.9	23.4	46.9	23.4
	LV Amps		8.47	16.90	18.00	9.57	19.5	19.9	20.3	10.8	11.1	20.8	16.9	19.1	17.5	36.0	19.1
QC250ESCB	HV Amps	KVA	26.6	50.0	50.0	26.6	50.0	50.0	50.0	26.6	26.6	50.0	53.1	53.1	26.6	50.0	26.6
	LV Amps		31.3	62.5	62.5	31.3	62.5	62.5	62.5	31.3	31.3	62.5	62.5	62.5	31.3	62.5	31.3
QC300ESCB	HV Amps	KVA	11.3	22.5	24.0	12.8	26.0	26.6	27.0	14.4	14.7	27.7	22.5	25.5	23.3	48.0	25.5
	LV Amps		35.4	66.7	66.7	35.4	66.7	66.7	66.7	35.4	35.4	66.7	70.8	70.8	35.4	66.7	35.4
QC350ESCB	HV Amps	KVA	46.9	93.8	93.8	46.9	93.8	93.8	93.8	46.9	46.9	93.8	93.8	93.8	46.9	93.8	46.9
	LV Amps		16.9	33.8	36.0	19.1	39.0	39.8	40.5	21.5	22.1	41.6	33.8	38.3	35.0	72.0	38.3
QC400ESCB	HV Amps	KVA	53.1	100.0	100.0	53.1	100.0	100.0	100.0	53.1	53.1	100.0	106	106	53.1	100	53.1
	LV Amps		62.5	125.0	125.0	62.5	125.0	125.0	125.0	62.5	62.5	125.0	125	125	62.5	125.0	62.5
QC450ESCB	HV Amps	KVA	22.6	45.0	48.0	25.5	52.0	53.1	54.0	28.7	29.4	55.4	45.0	51.0	46.7	96.0	51.0
	LV Amps		70.8	133.3	133.3	70.8	133.3	133.3	133.3	70.8	70.8	133.3	142	142	70.8	133	70.8
QC500ESCB	HV Amps	KVA	93.75	187.5	187.5	93.75	187.5	187.5	187.5	93.75	93.75	187.5	188	188	93.8	188	93.8
	LV Amps		33.9	67.6	72.1	38.3	78.0	79.7	81.1	43.1	44.2	83.1	67.5	76.5	70.0	144	76.5
QC550ESCB	HV Amps	KVA	106.3	200	200	106.3	200	200	200	106.3	106.3	200	213	213	106	200	106
	LV Amps		156.25	312.5	312.5	156.25	313	312.5	312.5	156.25	156.25	312.5	313	313	156	313	156
QC600ESCB	HV Amps	KVA	56.4	112.6	120.1	63.8	129.9	132.8	135.1	71.8	73.6	138.6	113	128	117	240	128
	LV Amps		177.1	333.3	333.3	177.1	333.3	333.3	333.3	177.1	177.1	333.3	354	354	177	333	177

SECTION 2



How to use the Selection Chart

1. From the top row of the “**Selection Chart**” locate the high and low voltage combination that is closest to the one you require.
2. Determine the quantity you required.
3. The corresponding connection diagram is indicated at the top of the Voltage / kVA column. See page 94 for the connection diagrams.
4. Move down that column to the kVA or Ampere rating equal to or greater than the rating required by the load.
5. From the far left column, obtain the transformer catalog number.
6. For dimensional information refer to the specifications table (Group C) on page 92.

Three Phase - Group C Selection Chart

Catalog Number	Low Voltage		173	200	208	362	380	400	419	436	457	480	480	346	379	400	416
	High Voltage		208	240	250	380	418	440	440	480	480	528	504	200	219	231	240
QUANTITY REQUIRED			2	2	2	2	2	2	2	2	2	2	2	3	3	3	3
CONNECTION DIAGRAM <small>(Refer to Page 94)</small>			5	5	5	6	7	7	8	7	8	7	8	9	9	9	9
Three Phase Connection Style			Delta Connected										Wye Connected				
QC05DTCB	HV Amps		1.04	1.04	1.04	2.08	1.04	1.04	2.08	1.04	2.08	1.04	2.08	1.04	1.04	1.04	1.04
	KVA		0.38	0.44	0.46	1.44	0.76	0.80	1.67	0.87	1.82	0.96	1.82	0.75	0.82	0.87	0.90
	LV Amps		1.25	1.25	1.25	2.29	1.15	1.15	2.29	1.15	2.29	1.15	2.19	1.25	1.25	1.25	1.15
QC10DTCB	HV Amps		2.08	2.08	2.08	4.17	2.08	2.08	4.17	2.08	4.17	2.08	4.17	2.08	2.08	2.08	2.08
	KVA		0.75	0.87	0.91	2.88	1.51	1.59	3.33	1.74	3.63	1.91	3.64	1.50	1.64	1.73	1.80
	LV Amps		2.50	2.50	2.50	4.58	2.29	2.29	4.58	2.29	4.58	2.29	4.38	2.50	2.50	2.50	2.50
QC15DTCB	HV Amps		3.13	3.13	3.13	6.25	3.13	3.13	6.25	3.13	6.25	3.13	6.25	3.13	3.13	3.13	3.13
	KVA		1.13	1.30	1.36	4.32	2.27	2.39	4.99	2.60	5.45	2.86	5.46	2.25	2.47	2.60	2.70
	LV Amps		3.75	3.75	3.75	6.88	3.44	3.44	6.88	3.44	6.88	3.44	6.56	3.75	3.75	3.75	3.75
QC20DTCB	HV Amps		4.17	4.17	4.17	8.33	4.17	4.17	8.33	4.17	8.33	4.17	8.33	4.17	4.17	4.17	4.17
	KVA		1.50	1.74	1.81	5.75	3.02	3.18	6.66	3.47	7.26	3.82	7.28	3.00	3.29	3.46	3.60
	LV Amps		5.00	5.00	5.00	9.17	4.58	4.58	9.17	4.58	9.17	4.58	8.75	5.00	5.00	5.00	5.00
QC25DTCB	HV Amps		5.21	5.21	5.21	10.4	5.21	5.21	10.40	5.21	10.40	5.21	10.40	5.21	5.21	5.21	5.21
	KVA		1.88	2.17	2.26	7.19	3.78	3.97	8.32	4.33	9.07	4.77	9.10	3.75	4.11	4.33	4.50
	LV Amps		6.25	6.25	6.25	11.50	5.73	5.73	11.50	5.73	11.50	5.73	10.90	6.25	6.25	6.25	6.25
QC35DTCB	HV Amps		7.29	7.29	7.29	14.6	7.29	7.3	14.6	7.3	14.6	7.29	14.6	7.29	7.29	7.29	7.29
	KVA		2.63	3.04	3.16	10.1	5.28	5.56	11.70	6.06	12.70	6.67	12.70	5.25	5.75	6.06	6.30
	LV Amps		8.75	8.75	8.75	16.0	8.0	8.0	16.0	8.0	16.0	8.02	15.3	8.75	8.75	8.75	8.75
QC50DTCB	HV Amps		10.4	10.4	10.4	20.8	10.4	10.4	20.8	10.4	20.8	10.4	20.8	10.4	10.4	10.4	10.4
	KVA		3.75	4.34	4.51	14.4	7.55	7.94	16.60	8.66	18.10	9.53	18.20	7.50	8.22	8.66	9.00
	LV Amps		12.5	12.5	12.5	22.9	11.5	11.5	22.9	11.5	22.9	11.5	21.9	12.5	12.5	12.5	12.5
QC75DTCB	HV Amps		15.6	15.6	15.6	31.3	15.6	15.6	31.3	15.6	31.3	15.6	31.3	15.6	15.6	15.6	15.6
	KVA		5.62	6.50	6.76	21.6	11.3	11.9	25.0	13.0	27.2	14.3	27.3	11.3	12.3	13.0	13.5
	LV Amps		18.8	18.8	18.8	34.4	17.2	17.2	34.4	17.2	34.4	17.2	32.8	18.8	18.8	18.8	18.8
Q1C0DTCB	HV Amps		20.8	20.8	20.8	41.7	20.8	20.8	41.7	20.8	41.7	20.8	41.7	20.8	20.8	20.8	20.8
	KVA		7.50	8.67	9.01	28.7	15.1	15.9	33.3	17.3	36.3	19.1	36.4	15.0	16.4	17.3	18.0
	LV Amps		25.0	25.0	25.0	45.8	22.9	22.9	45.8	22.9	45.8	22.9	43.8	25.0	25.0	25.0	25.0
Q1C5DTCF	HV Amps		31.3	31.3	31.3	62.5	31.3	31.3	62.5	31.3	62.5	31.3	62.5	31.3	31.3	31.3	31.3
	KVA		11.2	13.0	13.5	43.1	22.6	23.8	49.9	26.0	54.4	28.6	54.6	22.5	24.7	26.0	27.0
	LV Amps		37.5	37.5	37.5	68.8	34.4	34.4	68.8	34.4	68.8	34.4	65.6	37.5	37.5	37.5	37.5
Q002DTCF	HV Amps		41.7	41.7	41.7	83.3	41.7	41.7	83.3	41.7	83.8	41.7	83.3	41.7	41.7	41.7	41.7
	KVA		15.0	17.3	18.0	57.5	30.2	31.8	66.5	34.6	72.6	38.1	72.8	30.0	32.9	34.6	36.0
	LV Amps		50.0	50.0	50.0	91.7	45.8	45.8	91.7	45.8	91.7	45.8	87.5	50.0	50.0	50.0	50.0
Q003DTCF	HV Amps		62.5	62.5	62.5	125	62.5	62.5	125.0	62.5	125.0	62.5	125.0	62.5	62.5	62.5	62.5
	KVA		22.5	26.0	27.0	86.2	45.3	47.6	99.8	51.9	109.0	57.2	109.0	45.0	49.3	51.9	54.0
	LV Amps		75.0	75.0	75.0	138	68.8	68.8	138.0	68.8	138.0	68.8	131.0	75.0	75.0	75.0	75.0
Q005DTCF	HV Amps		104	104	104	208	104	104	208	104	208	104	208	104	104	104	104
	KVA		37.5	43.3	45.0	144.0	75.4	79.4	166.0	86.5	181.0	95.3	182.0	75.0	82.2	86.6	90.0
	LV Amps		125	125	125	229	115	115	229	115	229	115	219	125	125	125	125





Single Phase Specification Tables

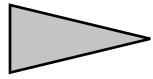

Group A

Primary Voltage	120 X 240
Secondary Voltage	12 X 24
50/60 Hertz	

VA	Catalog Number	Case Style (Pages 262)	Approx. Dimensions (Inches)			Approx. Weight (Lbs.)	Mtg Type W - Wall
			Width	Depth	Height		
50	QC05ERCB	NQ0	3.75	5.25	7.25	6	W
100	QC10ERCB	NQ0	3.75	5.25	7.25	7	W
150	QC15ERCB	NQ0	3.75	5.25	7.25	8	W
200	QC20ERCB	NQ1	4.50	5.75	7.25	11	W
250	QC25ERCB	NQ1	4.50	5.75	7.25	13	W
350	QC35ERCB	NQ1	4.50	5.75	7.25	14	W
500	QC50ERCB	NQ2	5.00	4.75	9.25	15	W
750	QC75ERCB	NQ2	5.00	4.75	9.25	18	W
1000	Q1C0ERCB	NQ3	5.88	5.50	10.50	25	W
1500	Q1C5ERCF	NQ4	7.00	6.50	11.75	36	W
2000	Q002ERCF	NQ4	7.00	6.50	11.75	46	W
3000	Q003ERCF	NQ5	10.00	7.75	17.25	65	W
5000	Q005ERCF	NQ5	10.00	7.75	17.25	105	W

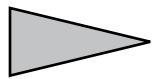

Group B

Primary Voltage	120 X 240
Secondary Voltage	16 X 32
50/60 Hertz	

VA	Catalog Number	Case Style (Pages 262)	Approx. Dimensions (Inches)			Approx. Weight (Lbs.)	Mtg Type W - Wall
			Width	Depth	Height		
50	QC05ESCB	NQ0	3.75	5.25	7.25	6	W
100	QC10ESCB	NQ0	3.75	5.25	7.25	7	W
150	QC15ESCB	NQ0	3.75	5.25	7.25	8	W
200	QC20ESCB	NQ1	4.50	5.75	7.25	11	W
250	QC25ESCB	NQ1	4.50	5.75	7.25	13	W
350	QC35ESCB	NQ1	4.50	5.75	7.25	14	W
500	QC50ESCB	NQ2	5.00	4.75	9.25	15	W
750	QC75ESCB	NQ2	5.00	4.75	9.25	18	W
1000	Q1C0ESCB	NQ3	5.88	5.50	10.50	25	W
1500	Q1C5ESCF	NQ4	7.00	6.50	11.75	36	W
2000	Q002ESCF	NQ4	7.00	6.50	11.75	46	W
3000	Q003ESCF	NQ5	10.00	7.75	17.25	65	W
5000	Q005ESCF	NQ5	10.00	7.75	17.25	105	W

SECTION 2





Single Phase Specification Tables

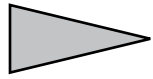

Group C

Primary Voltage	240 X 480
Secondary Voltage	24 X 48
50/60 Hertz	

VA	Catalog Number	Case Style (Pages 262)	Approx. Dimensions (Inches)			Approx. Weight (Lbs.)	Mtg Type W - Wall
			Width	Depth	Height		
50	QC05DTCB	NQ0	3.75	5.25	7.25	6	W
100	QC10DTCB	NQ0	3.75	5.25	7.25	7	W
150	QC15DTCB	NQ0	3.75	5.25	7.25	8	W
200	QC20DTCB	NQ1	4.50	5.75	7.25	11	W
250	QC25DTCB	NQ1	4.50	5.75	7.25	13	W
350	QC35DTCB	NQ1	4.50	5.75	7.25	14	W
500	QC50DTCB	NQ2	5.00	4.75	9.25	15	W
750	QC75DTCB	NQ2	5.00	4.75	9.25	18	W
1000	Q1C0DTCB	NQ3	5.88	5.50	10.50	25	W
1500	Q1C5DTCF	NQ4	7.00	6.50	11.75	36	W
2000	Q002DTCF	NQ4	7.00	6.50	11.75	46	W
3000	Q003DTCF	NQ5	10.00	7.75	17.25	65	W
5000	Q005DTCF	NQ5	10.00	7.75	17.25	105	W

Three Phase Specification Tables

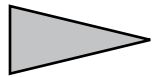

Group A

Primary Voltage	120 X 240
Secondary Voltage	12 X 24
50/60 Hertz	

VA	Catalog Number	Case Style (Pages 262)	Approx. Dimensions (Inches)			Approx. Weight (Lbs.)	Mtg Type W - Wall
			Width	Depth	Height		
50	QC05ERCB	NQ0	3.75	5.25	7.25	6	W
100	QC10ERCB	NQ0	3.75	5.25	7.25	7	W
150	QC15ERCB	NQ0	3.75	5.25	7.25	8	W
200	QC20ERCB	NQ1	4.50	5.75	7.25	11	W
250	QC25ERCB	NQ1	4.50	5.75	7.25	13	W
350	QC35ERCB	NQ1	4.50	5.75	7.25	14	W
500	QC50ERCB	NQ2	5.00	4.75	9.25	15	W
750	QC75ERCB	NQ2	5.00	4.75	9.25	18	W
1000	Q1C0ERCB	NQ3	5.88	5.50	10.50	25	W
1500	Q1C5ERCF	NQ4	7.00	6.50	11.75	36	W
2000	Q002ERCF	NQ4	7.00	6.50	11.75	46	W
3000	Q003ERCF	NQ5	10.00	7.75	17.25	65	W
5000	Q005ERCF	NQ5	10.00	7.75	17.25	105	W





Three Phase Specification Tables

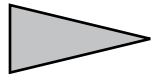

Group B

Primary Voltage	120 X 240
Secondary Voltage	16 X 32

50/60 Hertz

VA	Catalog Number	Case Style (Pages 262)	Approx. Dimensions (Inches)			Approx. Weight (Lbs.)	Mtg Type W - Wall
			Width	Depth	Height		
50	QC05ESCB	NQ0	3.75	5.25	7.25	6	W
100	QC10ESCB	NQ0	3.75	5.25	7.25	7	W
150	QC15ESCB	NQ0	3.75	5.25	7.25	8	W
200	QC20ESCB	NQ1	4.50	5.75	7.25	11	W
250	QC25ESCB	NQ1	4.50	5.75	7.25	13	W
350	QC35ESCB	NQ1	4.50	5.75	7.25	14	W
500	QC50ESCB	NQ2	5.00	4.75	9.25	15	W
750	QC75ESCB	NQ2	5.00	4.75	9.25	18	W
1000	Q1C0ESCB	NQ3	5.88	5.50	10.50	25	W
1500	Q1C5ESCF	NQ4	7.00	6.50	11.75	36	W
2000	Q002ESCF	NQ4	7.00	6.50	11.75	46	W
3000	Q003ESCF	NQ5	10.00	7.75	17.25	65	W
5000	Q005ESCF	NQ5	10.00	7.75	17.25	105	W

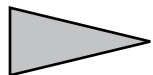

Group C

Primary Voltage	240 X 480
Secondary Voltage	24 X 48

50/60 Hertz

VA	Catalog Number	Case Style (Pages 262)	Approx. Dimensions (Inches)			Approx. Weight (Lbs.)	Mtg Type W - Wall
			Width	Depth	Height		
50	QC05DTCB	NQ0	3.75	5.25	7.25	6	W
100	QC10DTCB	NQ0	3.75	5.25	7.25	7	W
150	QC15DTCB	NQ0	3.75	5.25	7.25	8	W
200	QC20DTCB	NQ1	4.50	5.75	7.25	11	W
250	QC25DTCB	NQ1	4.50	5.75	7.25	13	W
350	QC35DTCB	NQ1	4.50	5.75	7.25	14	W
500	QC50DTCB	NQ2	5.00	4.75	9.25	15	W
750	QC75DTCB	NQ2	5.00	4.75	9.25	18	W
1000	Q1C0DTCB	NQ3	5.88	5.50	10.50	25	W
1500	Q1C5DTCF	NQ4	7.00	6.50	11.75	36	W
2000	Q002DTCF	NQ4	7.00	6.50	11.75	46	W
3000	Q003DTCF	NQ5	10.00	7.75	17.25	65	W
5000	Q005DTCF	NQ5	10.00	7.75	17.25	105	W

SECTION 2



Single Phase Connection Diagrams

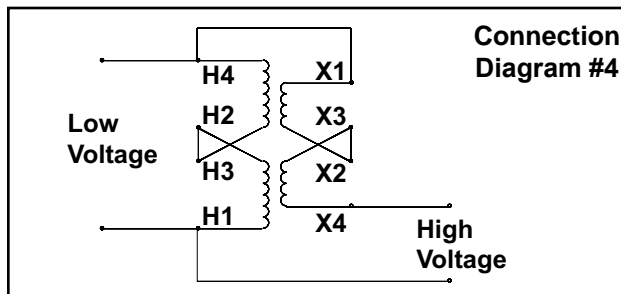
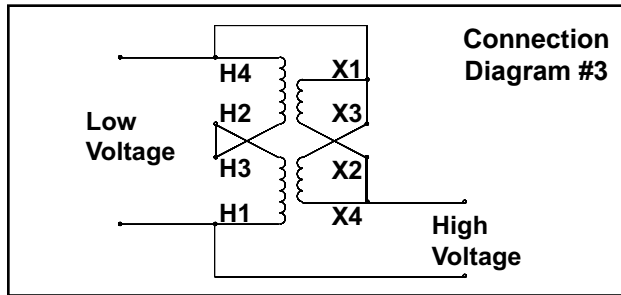
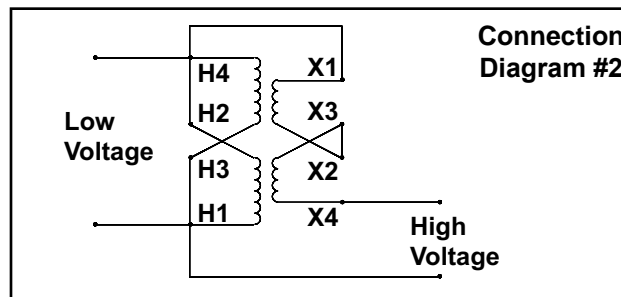
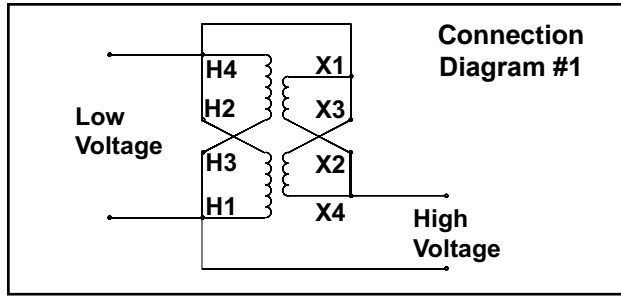

Three Phase Connection Diagrams

SECTION 2

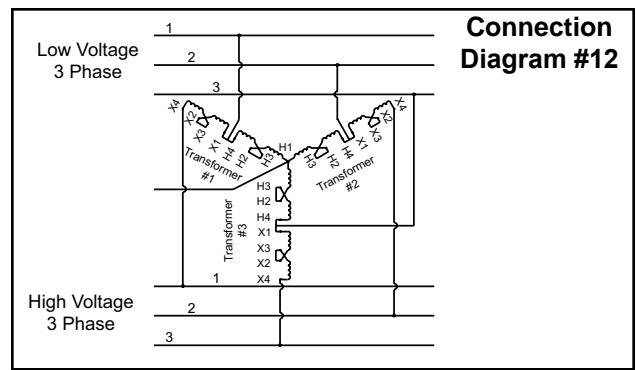
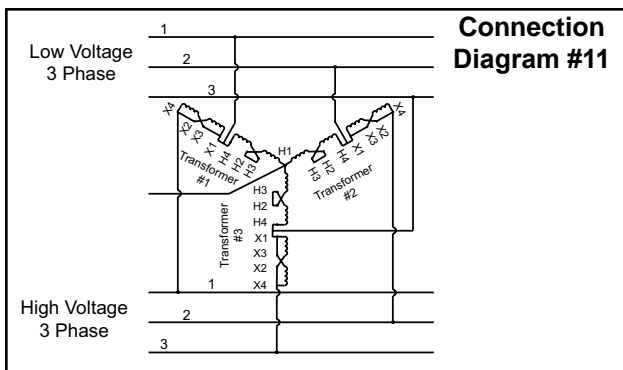
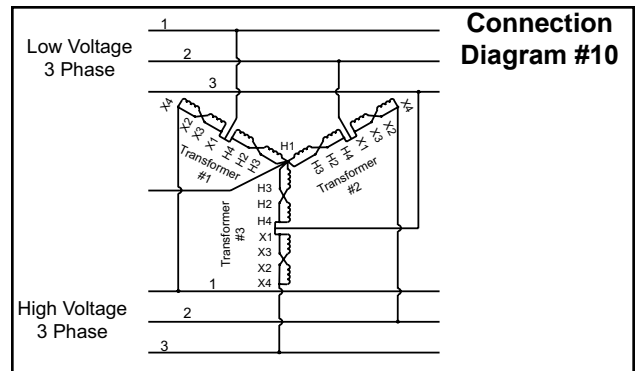
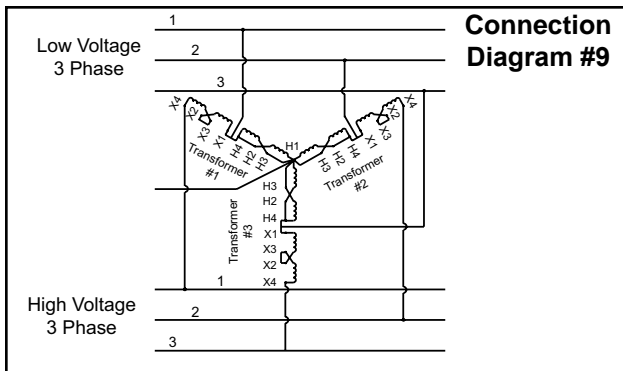
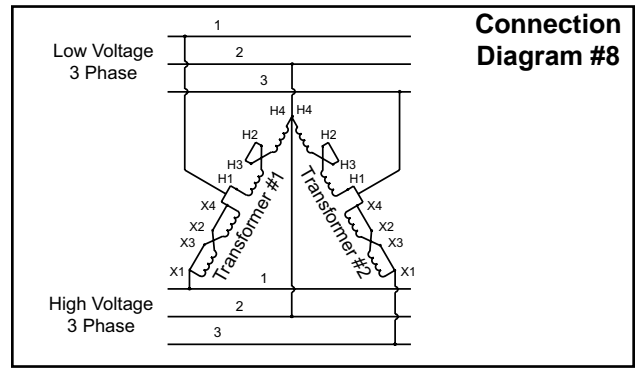
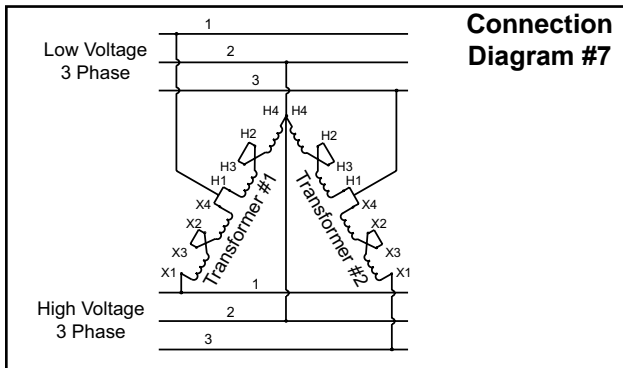
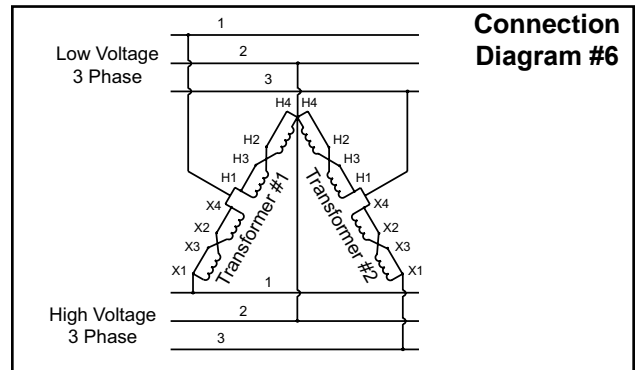
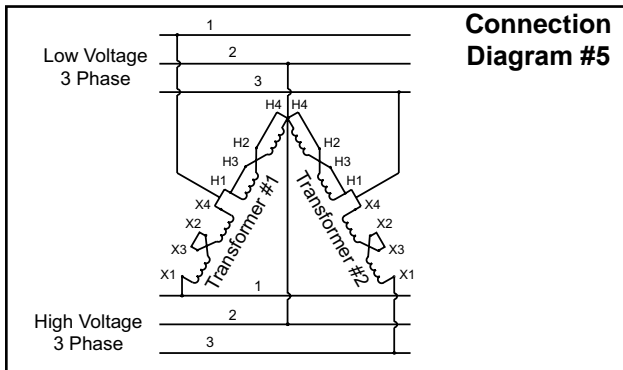

Buck-Boost Transformers - Questions & Answers

1. What is a buck-boost transformer?

Buck-boost transformers are small single phase transformers designed to lower (buck) or raise (boost) line voltage from 5-20%. The most common applications for buck-boost transformers include boosting 208 volts to 230 or 240 volts for air conditioning systems, boosting 110 to 120 volts and 240 to 277 volts for lighting applications, heating systems and induction motors of all types. Many applications exist where supply voltages are frequently above or below nominal.

Buck-boost transformers are conventional low voltage, single phase distribution transformers, with standard primary voltages of 120, 240 or 480 volts, and secondary voltages of 12, 16, 24, 32 or 48 volts. They are available in sizes ranging from 50 VA to 10,000 VA. The primary and secondary are wired together to form a single-winding autotransformer. Utilizing the additive and subtractive polarity, small amounts of voltage are either added or subtracted from a distribution circuit.

2. How does a buck-boost transformer differ from an isolating transformer?

A buck-boost transformer is manufactured as an isolating transformer, with separable primary and secondary, and is shipped from the factory in that configuration. When the end user at site connects it, the primary is connected to the secondary changing the transformer's electrical characteristics to those of an autotransformer. This provides the smaller voltage correction that is typical of buck-boost. The primary and secondary windings are no longer isolated as they are connected together.

3. What is the difference between a buck-boost transformer and an autotransformer?

As noted above, when the primary and secondary are connected together to buck or boost voltage, the transformer becomes an autotransformer. If the connection between the primary and secondary winding is not made, then the unit remains as an isolation transformer.

Applications

4. Why are they used?

A buck-boost transformer is a simple and effective way of correcting off-standard voltages. Electrical and electronic equipment is designed to operate within a standard tolerance of nominal supply voltages. When the supply voltage is consistently too high or low - typically more than 10%, the equipment will operate below peak efficiency.

5. Can buck-boost transformers be used to power low voltage circuits?

Installed as two-winding, isolation transformers, these units can be used to power low voltage circuits including control, lighting circuits, or other low voltage applications that require 12, 16, 24, 32 or 48 volts output, consistent with the secondary of these designs. The unit is connected as an isolating transformer and the nameplate kVA rating is the transformer's capacity.

Operation and Construction

6. Why do buck-boost transformers have 4 windings?

A four winding buck-boost transformer with 2 primary and 2 secondary windings can be connected eight different ways to provide a multitude of voltages and KVA's. This provides the flexibility necessary for the broad variety of applications. A two-winding transformer can only be connected in two different ways.



7. Will a Buck-Boost transformer stabilize voltage?

Autotransformers will not stabilize supply line voltage. The output voltage of an autotransformer is a function of the input voltage. If the input voltage varies, then the output voltage will also vary by the same percentage.

Load Data

8. Are there any restrictions on the type of load that can be operated from a Buck-Boost transformer?

There are no restrictions as to application for Buck-Boost, including single or three-phase motor loads.

9. As an Autotransformer, how can a Buck-Boost transformer supply kVA power?

This is a function of adding voltage - a small amount of voltage is added and a small amount of corresponding power capacity is added as well. For example, if the transformer is connected in such a way that 22 volts is added to a 208 volt primary, a 230 volt output will result.

Using this example, the calculation for autotransformer kVA is as follows:

$$\text{kVA} = \frac{\text{Output Volts} \times \text{Secondary Amps}}{1000}$$

$$\text{kVA} = \frac{230\text{V} \times 41.67 \text{ Amps}}{1000} = 9.58 \text{ KVA}$$

10. How are single phase and three phase load amps and load kVA calculated?

$$\text{Single phase Amps} = \frac{\text{kVA} \times 1000}{\text{Volts}}$$

$$\text{Three phase Amps} = \frac{\text{kVA} \times 1000}{\text{Volts} \times 1.73}$$

$$\text{Single phase kVA} = \frac{\text{Volts} \times \text{Amps}}{1000}$$

$$\text{Three phase kVA} = \frac{\text{Volts} \times \text{Amps} \times 1.73}{1000}$$

Three Phase

11. Can Buck-Boost transformers be used on three phase systems?

Interconnecting two or three single phase units will readily accommodate three phase systems - refer to the corresponding three phase section in this catalog. The number of units to be used in a three phase installation depends on the number of wires in the supply line. If the three phase supply is 4-wire wye, then three buck-boost transformers are required. If the three phase supply is 3-wire wye (neutral not available), two buck-boost transformers are needed.

12. Should Buck-Boost transformers be used to develop three phase 4 wire wye circuits from three phase 3 wire delta circuits?

No - a three-phase "wye" buck-boost transformer connection should be used only on a 4-wire source of supply. A delta to wye connection does not provide adequate current capacity to accommodate unbalanced currents flowing in the neutral wire of the 4-wire circuit.

13. Why isn't a 'closed delta' Buck-Boost connection recommended?

This connection requires more kVA power than a "wye" or open delta connection and phase shifting occurs on the output. The closed delta connection is more expensive and electrically inferior to other three phase connections.

Connection and Frequency

14. How do you know how to connect a Buck-Boost transformer?

A connection chart is provided with each unit that shows how to make the corresponding connections. These same charts are also shown in this section.

15. Can 60 Hertz Buck-Boost transformers be operated on 50 Hertz?

Due to 'saturation' of the core, 60 Hertz buck-boost transformers should only be operated at 60 Hertz, and not 50 Hertz. Units manufactured as 50 Hertz units will however, operate at 60 Hertz.

Nameplate Data

17. Why are buck-boost transformers shipped from the factory connected as isolating transformers, and not pre-connected autotransformers?

The same 4-winding buck-boost transformer can be connected eight different ways to provide a multitude of voltage combinations. The correct connection can best be determined by the user when assessing the supply voltage at site.

18. Why is the isolation transformer kVA rating shown on the nameplate instead of the autotransformer kVA rating?

Shipped as an isolating transformer, the nameplate is required to show the performance characteristics accordingly. Additionally, as an autotransformer, the eight different combinations of voltages and kVA's would be impractical to list on the nameplate. A connection chart, listing the various connections, is included with each unit.

Safety

19. Do Buck-Boost transformers present a safety hazard compared to conventional autotransformers?

Buck-boost transformers only change voltage by a small amount, such as 208 to 240 volts. This small increase does not represent a safety hazard. Conventional autotransformers, manufactured as single winding transformers, change much higher magnitudes of voltage, e.g. 480 to 240 volts. In a system where the line is grounded, it is possible to have 480 volts to ground when the expectations are that 240 volts is at the output. For this reason, qualified personnel only should maintain conventional autotransformers.

Sound Levels

20. How does the sound level differ between Buck-Boost and isolation transformers?

Buck-boost transformers, connected as autotransformers, will be quieter than an equivalent isolation transformer capable of handling the same load. The isolation transformer would have to be physically larger than the buck-boost transformer, and smaller transformers are quieter than larger ones. For example, a 10 kVA is 35 dba and a 75 kVA is 50 dba.

Cost and Life Expectancy

21. How does the costs compare between a Buck-Boost transformer and an Isolation transformer handling the same load?

For most buck-boost applications, the savings are about 75% compared to the use of an isolation transformer for the same application.

22. What is the life expectancy of a Buck-Boost transformer?

Buck-boost transformers have exactly the same life expectancy as other dry-type transformers.

23. Buck-Boost transformers are almost always installed as autotransformers. Does the National Electrical Code (NEC) permit the use of autotransformers?

Autotransformers are very common and recognized by all the safety and standard authorities. You can refer to N.E.C. Article 450-4, "Autotransformers 600 Volts, Nominal, or Less", as a reference publication. Item (a) details overcurrent protection for an autotransformer and item (b) covers an isolation transformer being field connected as an autotransformer for a buck-boost application.

24. When a Buck-Boost transformer is connected as an autotransformer, what is the procedure for determining the current rating of the overcurrent protective device, such as the fuse or circuit breaker?

The NEC Article 450-4 outlines overcurrent protection for autotransformers. It is reproduced as follows: "NEC 450-4 - Autotransformers 600 Volts, Nominal, or Less

(a) Overcurrent Protection. Each autotransformer 600 volts, nominal, or less shall be protected by an individual overcurrent device installed in series with each ungrounded input conductor. Such overcurrent device shall be rated or set at not more than 125 percent of the rated full load input current of the autotransformer. An overcurrent device shall not be installed in series with the shunt winding.

Exception: Where the rated input current of an autotransformer is 9 amperes or more and 125 percent of this current does not correspond to a standard rating of a fuse or non-adjustable circuit breaker; the next higher standard rating described in our section shall be permitted. When the rated input current is less than 9 amperes, an overcurrent device rated or set at not more than 167 percent of the input current shall be permitted.

(b) Transformer Field-Connected as an autotransformer. A transformer field-connected as autotransformers shall be identified for use at "elevated voltage".

Example: A 1 kVA transformer, Catalog No. Q1C0ERCB, is rated 120 x 240 to 12 x 24 volts. It is to be connected as an autotransformer to raise 208 to 230 volts single phase. When connected as an autotransformer in this application, the kVA rating is increased to 9.58 kVA, or 9,580 VA. This is the rating to be used for determining the full load input amps and the corresponding size of the overcurrent protection device, either a fuse or breaker.

$$\text{Full load input amps} = 9,580 \text{ Volt Amps} = 46 \text{ Amp}, 208 \text{ Volts}$$

When the full load current is greater than 9 amps, the overcurrent protection device - usually a fuse or non-adjustable breaker, the current rating can be up to 125 percent of the full load rating of the autotransformer input current.

$$\text{Max. current rating of the overcurrent device} = 46 \text{ amps} \times 125\% = 57.5 \text{ amps}$$

The National Electrical Code, Article 450-4 (a) Exception, permits the use of the next higher standard ampere rating of the overcurrent device. This is shown in Article 240-6 of the N.E.C.

$$\text{Max. size of the fuse or circuit breaker} = 60 \text{ amps}$$



SECTION 3

RM SERIES LINE REACTORS & RC SERIES DV/DT FILTERS

Single and Three Phase

Why Choose a Line Reactor?	100
Construction Features	103
Standard RM Line Reactor Specifications	105
Part Number Guide	106
RM Line Reactor Selection Tables	106
RM Line Reactor Core & Coil Specification Tables	108
RM Line Reactor Enclosed Specification Tables	110
RM Reactor Application and Connection Diagrams	112
Termination Details	112
RM Line Reactor Cross Reference Guide	113
RC DV/DT Filter Applications	114
RC DV/DT Filter Specifications	115
RC DV/DT Filter Selection Table	116
RM Line Reactor Open Style Reference Drawings	117
RC DV/DT Filter Open Style Reference Drawings	118

Why Choose A Line Reactor?

Utilizing variable speed drives to control motor speed has impacted industry both in energy savings and increased efficiencies. The challenge for today's designers is dealing with non-linear wave shapes generated by solid state devices.

By choosing a HPS line reactor, many line problems can be eliminated. Additionally, performance, life expectancy and efficiency of both the motor and the drive itself are significantly enhanced.

ELIMINATE NUISANCE TRIPPING

Transients due to switching on the utility line and harmonics from the drive system can cause intermittent tripping of circuit breakers. Furthermore, modern switchgear, equipped with solid state trip sensing devices is designed to react to peak current rather than RMS current. As switching transients can peak over 1000 volts, the resulting overvoltage will cause undesirable interruptions. A reactor added to your circuit restricts the surge current by utilizing its inductive characteristics, and therefore eliminates nuisance tripping.

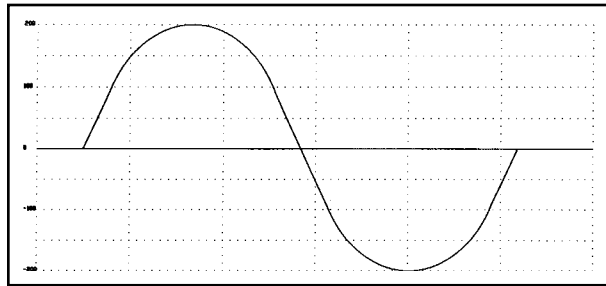

Normal sine wave from the utility supply.

EXTEND THE LIFE OF SWITCHING COMPONENTS

Due to the attenuation of line disturbances, the life of your solid state devices are extended when protected by the use of a HPS line reactor.

SATURATION

Due to the care in the selection of the core material with its optimum flux density, HPS line reactors will not saturate under the most adverse line conditions. Since the inductance is linear over a broader current range, equipment is protected even in extreme overcurrent circumstances.

EXTEND THE LIFE OF YOUR MOTOR

Line reactors, when selected for the output of your drive, will enhance the waveform and virtually eliminate failures due to output circuit faults. Subsequently, motor operating temperatures are reduced by 10 to 20 degrees and motor noise is reduced due to the removal of some of the high frequency harmonic currents.

LOW HEAT DISSIPATION

Particular attention has been focused on the design and field testing of this product line. The result is reactors with ideal operating features including low temperature rises and reduced losses. HPS reactors will operate efficiently and heat dissipation in your equipment will be of minimal concern.

MINIMIZE HARMONIC DISTORTION

Non-linear current waveforms contain harmonic distortion. By using a HPS line reactor you can limit the inrush current to the rectifier in your drive. The peak current is reduced, the waveform is rounded and harmonic distortion is minimized. Current distortion typically is reduced to 30%.

Severe harmonic current distortion can also cause the system voltage to distort. Often, high peak harmonic current drawn by the drive, causes “flat-topping” of the voltage waveform. Adding a reactor controls the current component, and voltage harmonic distortion is therefore reduced.

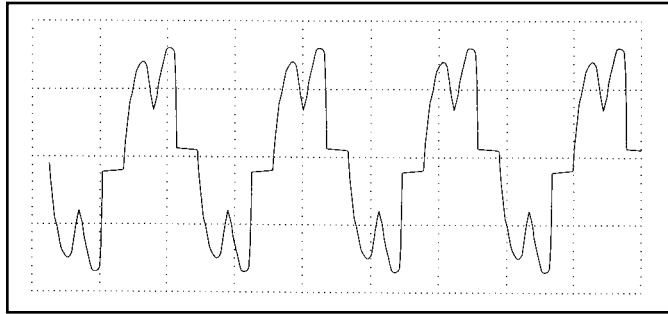

The total harmonic distortion of variable speed drives produces complex wave shapes such as the phase current shown above. The challenge for today's designers is to effectively minimize these line problems.

SHORT CIRCUIT CAPABILITY

HPS line reactors can withstand current under short circuit conditions, reducing the potential of severe damage to electronic equipment. In a short circuit, the inductance of the coil is necessary to limit overcurrent after the core has saturated. HPS has extensive experience in designing and testing dry-type transformers to withstand short circuits for the most demanding applications, and this experience has been applied to line reactor design.

REDUCE LINE NOTCHING

Whenever AC power is converted to DC by a rectifier using a non-linear device, such as an SCR, the process of commutation occurs. The result is a notch in the voltage waveform. The number of notches is a function of both the number of pulses and the number of SCR's in the rectifier.

Line reactors are used to provide the inductive reactance needed to reduce notching, which can adversely effect equipment operation.

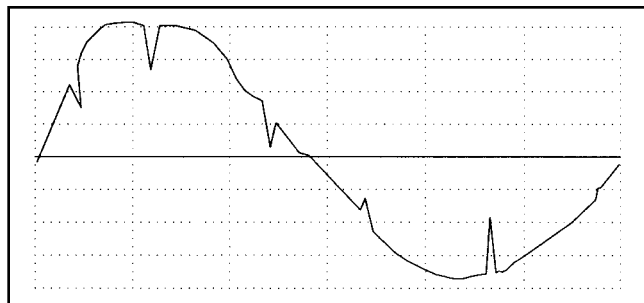

A voltage waveform illustrating line notching. Line reactors are used to provide the inductive reactance needed to reduce such notches.

Why Choose A Line Reactor continued...

IMPEDANCE RATINGS

Definition:

$$\% Z = \frac{(VD \times 100)}{VS} \times \sqrt{3}$$

Z = IMPEDANCE (three phase)

VD = VOLTAGE DROP ACROSS REACTOR

VS = VOLTAGE SUPPLY FOR RATED CURRENT TO FLOW THROUGH REACTOR

SELECTION - 3% OR 5% IMPEDANCE REACTOR

Choose 3% impedance reactors to satisfy most solid state applications in North America. Reactors rated for 3% impedance are ideal for absorbing normal line spikes and motor current surges, and will prevent most nuisance line tripping of circuit protection devices or equipment.

Where considerably higher line disturbances are present, a 5% impedance reactor may be required. Additionally, if the application is overseas, or when it is necessary to comply to IEEE 519, the higher impedance reactor is recommended. These units may also be selected to further reduce harmonic current and frequencies if desirable or to both extend motor life or diminish motor noise.

LINE REACTORS OR DRIVE ISOLATION TRANSFORMERS ?

When true line isolation is required, such as limiting short circuit current, or where it is necessary to step up or step down voltage, use a drive isolation transformer. HPS carries an extensive line of drive isolation transformers in stock. Refer to Section 4 for information on Drive Isolation transformers.

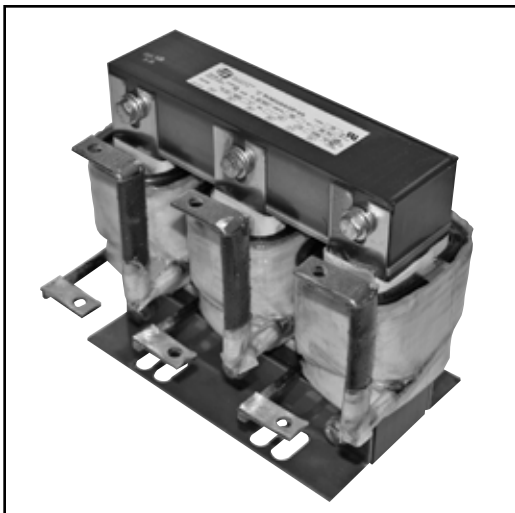

The RM Line Reactor . . .

CORE

The quality and performance of a line reactor is fundamentally dependant on its ability to withstand harmonics and transients in what is clearly a difficult environment. The bonding and clamping techniques of the gapped core also significantly impacts its performance characteristics.

HPS has paid particular attention to these basics to ensure both reliable and consistent performance.

Core materials, manufacturing and assembly processes have been carefully evaluated to produce optimum losses and sound levels necessary for this product.

COILS

Conductors are precision wound for optimum short circuit withstandability and electrical balance are used throughout the RM line. Choice of conductors, winding techniques and cooling ducts are precisely selected to assure the highest continuous, reliable performance.

INSULATION SYSTEM

HPS Line Reactors are designed to meet the most difficult temperature environments. On units up to 160 amps, RM line reactors have a 115°C temperature rise designed for 200°C Insulation Class. This results in a permissible 24 hour maximum ambient of 50°C and an average of 40°C continuously.

On units larger than 160 amps, Class 220 Insulation is used throughout with a maximum permissible continuous ambient temperature of 60°C. These temperature tests are all measured at

150% rated 60 Hz current. The extra 50% current during the temperature test is to consider the worst heating effect due to the present of harmonics in the motor drive system. Generally harmonic heating effect is approximately 30% and depends on individual drive system. For further information on temperature rises, please consult our sales offices.

VPI IMPREGNATION

Every reactor is fully VPI vacuum and pressure processed with VT (vinyl-toluene) Polyester Resin. This modern, vinyl-toluene based resin with its thicker build, offers significant benefits for electrical, mechanical and thermal properties.

This impregnation process and material results in a much improved dielectric constant, dissipation factor, bonding strength and dielectric breakdown (volts per mil) than any other impregnation material including the more traditional oil modified epoxies and varnishes.

Vacuum impregnation is considered vital for the integrity of electrical equipment located in such sensitive locations. The core and coil assembly is

finished with a clear resin.

TERMINATIONS

Custom connections are provided for in several ways. Finger-proof-terminal blocks are provided on three model ranges, and terminal pads are supplied on higher current ratings. Refer to the dimensional summary for details. All connections are brazed to ensure electrical integrity.

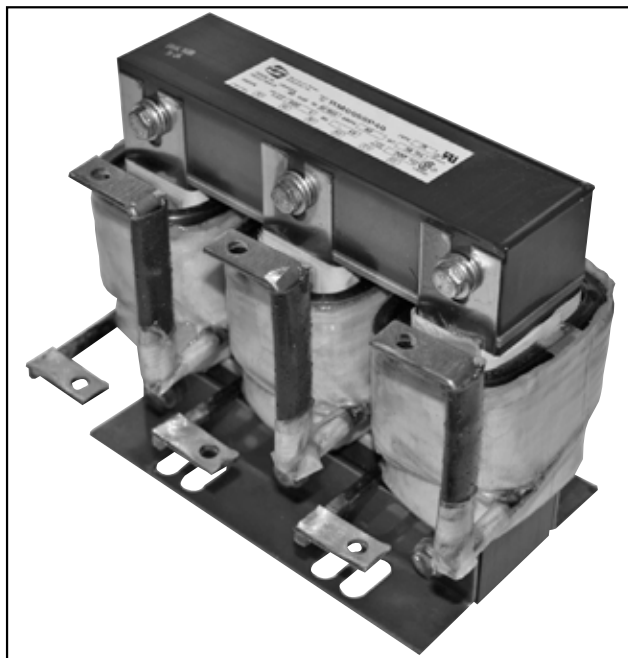

... Features of Construction

ENCLOSURES

Enclosed reactors are standard as either NEMA 2 or 3R. Units in NEMA 3R enclosures are suitable for floor or wall mounting. Wall mounting is available on NEMA 3R units up to 600 lbs. Please consult customer service for details.

Enclosures are finished with a 7 stage phosphate process with baked enamel ANSI 61 grey.

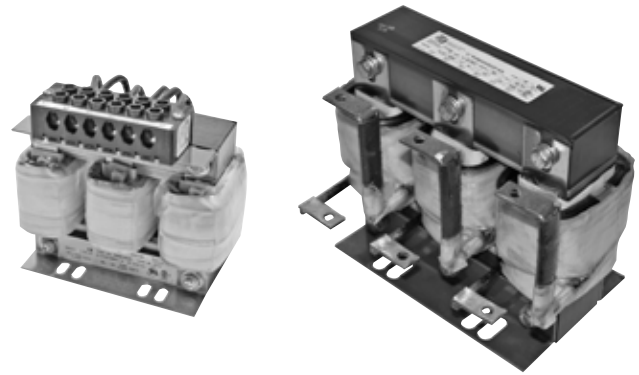

This approval is inclusive to 2000 amps and 8.6 kV class, and may be of interest for any special applications.

Our products are built in accordance with and meet UL 508, UL 506 and CSA C22.2 NO.66 standards.

INPUT AND OUTPUT SIDE REACTORS

HPS three phase Line Reactors are designed for both the input and output side of variable speed drives including Insulated Gate Bipolar Transistor (IGBT) type inverters.

SPECIALS

For special applications or for any features that you may require beyond the standard line listed, please contact our sales offices.



QUALITY CONTROL

Every reactor is production line tested in accordance with the requirements for UL, ANSI, NEMA and CSA. This confirms that every unit meets our highest expectations for Quality Assurance.

Additionally, line reactors have been short circuit tested at a certified laboratory to confirm the withstandability of our reactors to short circuits that may be present in a distribution system. Tests were done in accordance with ANSI C57.12.91 at 25 times rated current for 2 seconds. Those test results are available upon request successfully withstanding this test ensured that the RM line reactor will survive power stresses such as short circuits that may be present in a distribution circuit.

UL and CSA CERTIFICATION

A vital assurance for our customers is the approval of this product line to national standards.

Our open and enclosed style reactors are recognized by UL and certified by CSA as follows:

UL File No.: E61431

CSA File No.: LR3902



Standard Three Phase Line Reactor Specifications

RATINGS:

Nominal Inductance +/- 10% @ rated current.
 95% of nominal inductance @ 150% rated current.
 50% of nominal inductance @ 350% of rated current.

The above performance indicates that even at very substantial overload conditions (even beyond what other equipment in the circuit could tolerate), the RM Line Reactor will still provide current limiting performance against total harmonic distortion generated by the drive system.

TEMPERATURE RISE:

115° C on units up to 160 amps; average ambient of 40°C.
 115° C on units larger than 160 amps; average ambient of 60° C.

INSULATION SYSTEM:

200°C Temperature Class up to 160 amps.
 220°C Temperature Class over 160 amps.

FREQUENCY:

60 Hz Fundamental Current Maximum.

COOLING METHOD:

Natural convection

SYSTEM VOLTAGE:

1.2kV Maximum

APPROVALS:

UL File No.: E61431
 CSA File No.: LR 3902
 CE Mark (IEC 61558-2-20:2000)

SOUND LEVEL:

2 to 18 amps: 58 dBA
 130 to 320 amps: 70 dBA
 25 to 100 amps: 64 dBA
 400 to 1200 amps: 75 dBA

ENCLOSURE: (when specified)

NEMA 2 or NEMA 3R, ANSI 61 Grey, UL50

HARMONIC WITHSTAND:

HPS reactors are designed to withstand typical harmonics associated with both the input and output side of AC variable speed drives including IGBT type inverter drives. For additional information, contact our sales office.

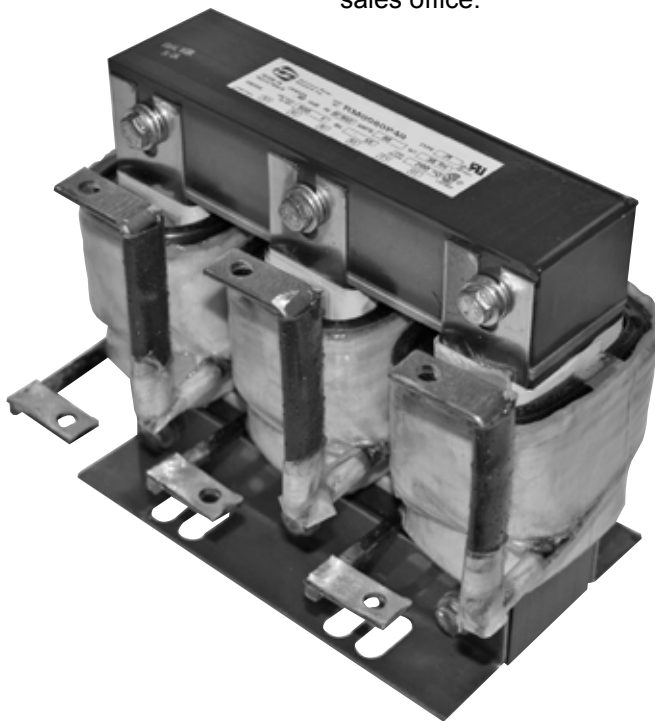

RM Series Line Reactor Selection Tables

Line Reactor Part Number Guide

RM 0002 M 32 * _

Further suffix to follow.
Add suffix "E" for Enclosure.

Inductance Value
 The inductance value is preceded with a letter to designate the position of the decimal point to determine the inductance. The letters are as follows:
 'M' XX. mH
 'N' X.X mH
 'P' 0.XX mH
 'U' .0XX mH or XX.0 uH

Example: M32 is 32.0 mH
 4 digits for current rating
 In-Line Reactor

Note: As all characters of the P/N represent performance values of the reactor, P/N's are not completely sequential. They are sorted by current rating.

* Add the Suffix "E" to the standard part number for an Enclosed unit.

HP Rating	240 Volt - 60 Hz			
	3% Impedance		5% Impedance	
	P/N	Amps	P/N	Amps
0.5	RM0004N65	4	RM0004M12	4
1	RM0004N30	4	RM0004N65	4
1.5	RM0008N30	8	RM0008N50	8
2	RM0008N15	8	RM0008N30	8
3	RM0012N13	12	RM0012N25	12
5	RM0018P80	18	RM0018N15	18
7.5	RM0025P50	25	RM0025N12	25
10	RM0035P40	35	RM0035P80	35
15	RM0045P30	45	RM0055P50	55
20	RM0055P25	55	RM0055P50	55
25	RM0080P20	80	RM0080P40	80
30	RM0080P20	80	RM0080P23	80
40	RM0130P10	130	RM0110P18	110
50	RM0130P10	130	RM0130P20	130
60	RM0160U75	160	RM0160P15	160
75	RM0200U55	200	RM0200P11	200
100	RM0250U45	250	RM0250U90	250
125	RM0320U40	320	RM0320U75	320
150	RM0400U30	400	RM0400U61	400
200	RM0500U25	500	RM0500U50	500
250	RM0600U20	600	RM0600U40	600
300	RM0750U15	750	RM0750U25	750
350	RM0900U13	900	RM0900U26	900
400	RM1000U11	1000	RM1000U18	1000
500	RM1200U10	1200	RM1200U15	1200

HP Rating	480 Volt - 60 Hz			
	3% Impedance		5% Impedance	
	P/N	Amps	P/N	Amps
1	RM0002M12	2	RM0002M20	2
1.5	RM0004N91	4	RM0004M12	4
2	RM0004N65	4	RM0004M12	4
3	RM0008N50	8	RM0008N75	8
5	RM0008N30	8	RM0008N50	8
7.5	RM0012N25	12	RM0012N42	12
10	RM0018N15	18	RM0018N25	18
15	RM0025N12	25	RM0025N20	25
20	RM0035P80	35	RM0035N17	35
25	RM0035P80	35	RM0035N12	35
30	RM0045P70	45	RM0045N12	45
40	RM0055P50	55	RM0055P85	55
50	RM0080P40	80	RM0080P70	80
60	RM0080P40	80	RM0080P70	80
75	RM0110P30	110	RM0110P45	110
100	RM0130P20	130	RM0130P30	130
125	RM0160P15	160	RM0160P23	160
150	RM0200P11	200	RM0200P24	200
200	RM0250U90	250	RM0250P15	250
250	RM0320U75	320	RM0320P13	320
300	RM0400U61	400	RM0400P11	400
350	RM0500U50	500	RM0500U85	500
400	RM0500U50	500	RM0500U85	500
500	RM0600U40	600	RM0600U65	600
600	RM0750U36	750	RM0750U60	750
700	RM0900U26	900	RM0900U43	900
800	RM1000U29	1000	RM1000U38	1000
1000	RM1200U18	1200	RM1200U30	1200

HP Rating	600 Volt - 60 Hz			
	3% Impedance		5% Impedance	
	P/N	Amps	P/N	Amps
1	RM0002M20	2	RM0002M32	2
1.5	RM0002M12	2	RM0002M20	2
2	RM0004M12	4	RM0004M22	4
3	RM0004N91	4	RM0004M12	4
5	RM0008N50	8	RM0008N75	8
7.5	RM0012N31	12	RM0012N51	12
10	RM0012N25	12	RM0012N42	12
15	RM0018N15	18	RM0018N25	18
20	RM0025N12	25	RM0025N20	25
25	RM0035N12	35	RM0035N17	35
30	RM0035P80	35	RM0035N17	35
40	RM0045P70	45	RM0045N12	45
50	RM0055P50	55	RM0055P85	55
60	RM0080P40	80	RM0080P70	80
75	RM0080P40	80	RM0080P70	80
100	RM0110P30	110	RM0110P45	110
125	RM0130P20	130	RM0130P37	130
150	RM0160P23	160	RM0160P32	160
200	RM0200P19	200	RM0200P24	200
250	RM0250P15	250	RM0250P19	250
300	RM0320U96	320	RM0320P16	320
350	RM0400U82	400	RM0400P14	400
400	RM0400U82	400	RM0400P14	400
500	RM0500U57	500	RM0500U96	500
600	RM0600U65	600	RM0600U80	600
700	RM0700U41	700	RM0700U68	700
800	RM0750U36	750	RM0750U60	750
900	RM0900U32	900	RM0900U53	900
1000	RM1000U29	1000	RM1000U48	1000
1200	RM1200U24	1200	RM1200U40	1200

SECTION 3



HP Rating	525 Volt - 50 Hz			
	3% Impedance		5% Impedance	
	P/N	Amps	P/N	Amps
1	RM0002M20	2	RM0002M32	2
1.5	RM0002M12	2	RM0002M20	2
2	RM0004M12	4	RM0004M22	4
3	RM0004N65	4	RM0004M12	4
5	RM0008N50	8	RM0008N75	8
7.5	RM0012N31	12	RM0012N51	12
10	RM0012N25	12	RM0012N42	12
15	RM0018N15	18	RM0018N25	18
20	RM0025N12	25	RM0025N20	25
25	RM0035N12	35	RM0035N17	35
30	RM0035P80	35	RM0035N17	35
40	RM0045P70	45	RM0045N12	45
50	RM0055P50	55	RM0055P85	55
60	RM0080P40	80	RM0080P70	80
75	RM0080P40	80	RM0080P70	80
100	RM0110P30	110	RM0110P45	110
125	RM0130P20	130	RM0130P37	130
150	RM0160P23	160	RM0160P32	160
200	RM0200P19	200	RM0200P24	200
250	RM0250P15	250	RM0250P19	250
300	RM0320U96	320	RM0320P16	320
350	RM0400U82	400	RM0400P14	400
400	RM0400U82	400	RM0400P14	400
500	RM0500U57	500	RM0500U96	500
600	RM0600U65	600	RM0600U80	600
700	RM0700U41	700	RM0700U68	700
800	RM0750U36	750	RM0750U60	750
900	RM0900U32	900	RM0900U53	900
1000	RM1000U29	1000	RM1000U48	1000
1200	RM1200U24	1200	RM1200U40	1200

HP Rating	660 Volt - 50 Hz			
	3% Impedance		5% Impedance	
	P/N	Amps	P/N	Amps
1	RM0002M32	2	Consult Factory	2
1.5	RM0002M20	2	RM0002M32	2
2	RM0004M22	4	Consult Factory	4
3	RM0004M12	4	RM0004M22	4
5	RM0008N75	8	Consult Factory	8
7.5	RM0008N50	8	RM0008N75	8
10	RM0012N42	12	Consult Factory	12
15	RM0018N25	18	Consult Factory	18
20	RM0025N20	25	Consult Factory	25
25	RM0025N20	25	Consult Factory	25
30	RM0035N17	35	Consult Factory	35
40	RM0035N12	35	RM0035N17	35
50	RM0055P85	55	Consult Factory	55
60	RM0055P85	55	Consult Factory	55
75	RM0080P70	80	Consult Factory	80
100	RM0080P40	80	RM0080P70	80
125	RM0110P45	110	Consult Factory	110
150	RM0130P30	130	Consult Factory	130
200	RM0160P23	160	Consult Factory	160
250	RM0200P19	200	Consult Factory	200
300	RM0250P15	250	Consult Factory	250
350	RM0320P13	320	Consult Factory	320
400	RM0320P13	320	Consult Factory	320
500	RM0400U82	400	RM0400P14	400
600	RM0500U85	500	Consult Factory	500
700	RM0600U65	600	Consult Factory	600
800	RM0700U68	700	Consult Factory	700
900	RM0750U60	750	Consult Factory	750
1000	RM0900U43	900	Consult Factory	900
1200	RM1000U38	1000	Consult Factory	1000

HP Rating	690 Volt - 50 Hz			
	3% Impedance		5% Impedance	
	P/N	Amps	P/N	Amps
1	RM0002M32	2	Consult Factory	2
1.5	RM0002M20	2	Consult Factory	2
2	RM0002M20	2	RM0002M32	2
3	RM0004M12	4	RM0004M22	4
5	RM0008N75	8	Consult Factory	8
7.5	RM0008N50	8	Consult Factory	8
10	RM0012N42	12	Consult Factory	12
15	RM0018N25	18	Consult Factory	18
20	RM0018N25	18	Consult Factory	18
25	RM0025N20	25	Consult Factory	25
30	RM0035N17	35	Consult Factory	35
40	RM0035N12	35	Consult Factory	35
50	RM0045N12	45	Consult Factory	45
60	RM0055P85	55	Consult Factory	55
75	RM0080P70	80	Consult Factory	80
100	RM0080P40	80	Consult Factory	80
125	RM0110P45	110	Consult Factory	110
150	RM0130P30	130	Consult Factory	130
200	RM0160P23	160	Consult Factory	160
250	RM0200P19	200	Consult Factory	200
300	RM0250P19	250	Consult Factory	250
350	RM0320P16	320	Consult Factory	320
400	RM0320P13	320	Consult Factory	320
500	RM0400P11	400	Consult Factory	400
600	RM0500U85	500	Consult Factory	500
700	RM0600U65	600	Consult Factory	600
800	RM0600U65	600	Consult Factory	600
900	RM0700U68	700	Consult Factory	700
1000	RM0750U60	750	Consult Factory	750
1200	RM0900U43	900	Consult Factory	900



Standard Three Phase Line Reactor Core & Coil Specification Charts

Current (Amps)	Part Number	Inductance	Watts Loss	Dimensions					Mtg Slot/ Hole Size	Dim. Fig. # (Page 117)	Weight (Lbs.)
				W	D	H	Mtg. W	Mtg. D			
2	RM0002M12	12.0	7	4.40	2.83	3.33	1.44/2.56	1.77	.281 x .625	1	2
2	RM0002M20	20.0	9	4.40	2.83	3.33	1.44/2.56	1.77	.281 x .625	1	3
2	RM0002M32	32.0	13	4.40	2.83	3.33	1.44/2.56	1.77	.281 x .625	1	3
4	RM0004M12	12.0	21	4.40	3.33	3.33	1.44/2.56	2.37	.281 x .625	1	4
4	RM0004M22	22.0	25	6.00	3.30	4.80	2.00/3.00	2.09	.281 x .625	3	8
4	RM0004N30	3.00	7	4.40	2.83	3.33	1.44/2.56	1.77	.281 x .625	1	2
4	RM0004N65	6.50	13	4.40	2.83	3.33	1.44/2.56	1.77	.281 x .625	1	3
4	RM0004N91	9.10	15	4.40	3.33	3.33	1.44/2.56	2.37	.281 x .625	1	3
8	RM0008N15	1.50	11	4.40	2.83	3.33	2.00	1.77	.281 x .625	1	3
8	RM0008N30	3.00	25	4.40	2.83	3.33	2.00	1.77	.281 x .625	1	3
8	RM0008N50	5.00	31	4.40	3.33	3.33	2.00	2.37	.281 x .625	1	4
8	RM0008N75	7.50	31	6.00	3.55	4.80	2.00/3.00	2.34	.281 x .625	3	9
12	RM0012N13	1.30	23	4.40	2.83	3.33	2.00	1.77	.281 x .625	1	3
12	RM0012N25	2.50	26	6.00	3.30	4.80	2.00/3.00	2.09	.281 x .625	3	8
12	RM0012N31	3.10	30	6.00	3.55	4.80	2.00/3.00	2.34	.281 x .625	3	9
12	RM0012N42	4.20	34	6.00	3.80	4.80	2.00/3.00	2.59	.281 x .625	3	10
12	RM0012N51	5.10	39	6.05	3.80	4.80	2.00/3.00	2.59	.281 x .625	3	13
18	RM0018N15	1.50	29	6.00	3.55	4.80	2.00/3.00	2.34	.281 x .625	3	9
18	RM0018N25	2.50	40	6.00	3.84	4.80	2.00/3.00	2.84	.281 x .625	2	13
18	RM0018P80	0.80	19	6.00	3.30	4.80	2.00/3.00	2.09	.281 x .625	3	7
25	RM0025N12	1.20	44	6.10	3.84	5.70	2.00/3.00	2.34	.281 x .625	2	10
25	RM0025N20	2.00	59	7.15	3.75	5.60	3.00	2.87	.38 x .63	3	18
25	RM0025P50	0.50	23	6.00	3.84	5.70	2.00/3.00	2.09	.281 x .625	2	7
35	RM0035N12	1.20	75	8.50	4.37	6.88	3.00/4.20	3.12	.44 X 1.00	3	26
35	RM0035N17	1.70	90	8.60	4.87	6.93	3.00/4.20	3.62	.44 X 1.00	3	35
35	RM0035P40	0.40	36	6.00	3.34	5.70	2.00/3.00	2.34	.281 x .625	2	9
35	RM0035P80	0.80	51	7.00	3.75	5.61	3.00	2.87	.38 x .63	3	17
45	RM0045N12	1.20	100	8.50	4.37	6.88	3.00/4.20	3.62	.44 X 1.00	3	35
45	RM0045P30	0.30	33	6.00	3.84	5.70	2.00/3.00	2.84	.281 x .625	2	13
45	RM0045P70	0.70	64	6.90	4.45	5.60	3.00	3.37	.38 x .63	3	22
55	RM0055P25	0.25	39	6.05	3.84	5.70	2.00/3.00	2.84	.281 x .625	2	12
55	RM0055P50	0.50	75	8.50	4.37	6.88	3.00/4.20	3.12	.44 X 1.00	3	26
55	RM0055P85	0.85	110	8.50	4.87	6.95	3.00/4.20	3.62	.44 X 1.00	3	35
80	RM0080P20	0.20	88	8.50	4.37	6.88	3.00/4.20	3.12	.44 X 1.00	4	26
80	RM0080P23	0.23	70	8.50	4.87	6.88	3.00/4.20	3.62	.44 X 1.00	4	33
80	RM0080P40	0.40	138	9.40	4.74	6.95	3.00/4.20	3.62	.44 X 1.00	4	36
80	RM0080P70	0.70	140	10.50	5.85	8.35	3.60/4.80	4.23	.44 X 1.25	4	63
110	RM0110P15	0.15	86	8.50	5.44	6.88	3.00/4.20	3.12	.44 X 1.00	4	27
110	RM0110P18	0.18	95	8.50	4.87	6.88	3.00/4.20	3.62	.44 X 1.00	4	35
110	RM0110P30	0.30	123	10.70	5.85	8.35	3.60/4.80	4.23	.44 X 1.25	4	52
110	RM0110P45	0.45	130	10.50	5.85	8.29	3.60/4.80	4.23	.44 X 1.25	4	63
130	RM0130P10	0.10	95	8.50	4.37	6.88	3.00/4.20	3.12	.44 X 1.00	4	27
130	RM0130P20	0.20	115	10.70	5.35	8.35	3.60/4.80	3.73	.44 X 1.25	4	41
130	RM0130P30	0.30	142	10.70	5.85	8.29	3.60/4.80	4.23	.44 X 1.25	4	53
130	RM0130P37	0.37	143	10.70	6.35	8.32	3.60/4.80	4.73	.44 X 1.25	4	75
160	RM0160P15	0.15	129	10.50	5.35	8.31	3.60/4.80	3.73	.44 X 1.25	4	46
160	RM0160P23	0.23	142	10.90	6.35	8.29	3.60/4.80	4.73	.44 X 1.25	4	66
160	RM0160P32	0.32	141	10.50	8.35	8.29	3.60/4.80	6.73	.44 X 1.25	4	104
160	RM0160U75	0.08	100	8.50	5.44	6.91	3.00/4.20	3.12	.44 X 1.00	4	29

SECTION 3



Standard Three Phase Line Reactor Core & Coil Specification Charts

Current (Amps)	Part Number	Inductance	Watts Loss	Dimensions					Mtg Slot/ Hole Size	Dim. Fig. # (Page 117)	Weight (Lbs.)
				W	D	H	Mtg. W	Mtg. D			
200	RM0200P11	0.11	114	10.50	6.10	8.35	3.60/4.80	4.48	.44 X 1.25	4	52
200	RM0200P19	0.190	138	10.50	7.85	8.29	3.60/4.80	6.23	.44 X 1.25	4	93
200	RM0200P24	0.240	164	10.50	8.35	8.29	3.60/4.80	6.73	.44 X 1.25	4	105
200	RM0200U55	0.055	89	8.50	4.87	7.05	3.00/4.20	3.62	.44 X 1.00	4	37
250	RM0250P15	0.150	188	13.75	6.75	11.43	4.80	5.44	.44 X 1.00	5	119
250	RM0250P19	0.190	203	13.75	7.25	11.43	4.80	5.94	.44 X 1.00	5	137
250	RM0250U45	0.045	90	10.50	5.35	8.31	3.60/4.80	3.73	.44 X 1.25	4	40
250	RM0250U90	0.090	131	10.50	6.35	8.35	3.60/4.80	4.73	.44 X 1.25	4	65
320	RM0320P13	0.13	245	13.75	7.75	11.43	4.80	6.44	.44 X 1.00	5	127
320	RM0320P16	0.160	270	13.75	8.25	11.43	4.80	6.44	.44 X 1.00	5	146
320	RM0320U40	0.040	94	10.50	6.85	8.29	3.60/4.80	5.23	.44 X 1.25	4	69
320	RM0320U75	0.075	184	13.75	7.25	11.43	4.80	5.94	.44 X 1.00	5	87
320	RM0320U96	0.096	214	13.75	6.25	11.43	4.80	4.93	.44 X 1.00	5	107
400	RM0400P11	0.11	278	13.75	7.75	11.43	4.80	6.44	.44 X 1.00	5	156
400	RM0400P14	0.14	305	18.00	11.00	14.00	6.00	8.25	0.563	6	253
400	RM0400U30	0.030	130	10.50	6.35	8.29	3.60/4.80	4.73	.44 X 1.25	4	61
400	RM0400U61	0.061	177	13.75	6.75	11.43	4.80	5.44	.44 X 1.00	5	115
400	RM0400U82	0.082	210	13.75	7.75	11.43	4.80	6.44	.44 X 1.00	5	148
500	RM0500U25	0.025	152	13.75	7.75	11.43	4.80	6.44	.44 X 1.00	5	100
500	RM0500U50	0.05	196	13.75	7.75	11.43	4.80	6.44	.44 X 1.00	5	151
500	RM0500U57	0.057	217	13.75	9.63	11.43	4.80	6.94	.44 X 1.00	5	168
500	RM0500U85	0.085	280	13.75	9.75	11.43	4.80	8.44	.44 X 1.00	5	225
500	RM0500U96	0.096	317	22.00	10.75	20.50	6.00	8.75	0.75	6	282
600	RM0600U20	0.020	147	13.75	8.25	11.43	4.80	6.56	.44 X 1.00	5	115
600	RM0600U40	0.040	223	13.75	8.25	11.43	4.80	6.94	.44 X 1.00	5	177
600	RM0600U65	0.065	290	13.75	9.75	11.43	4.80	8.44	.44 X 1.00	5	230
600	RM0600U80	0.080	340	22.50	12.63	20.50	7.50	8.75	0.75	6	310
700	RM0700U41	0.041	276	22.50	13.00	20.25	6.00	8.25	0.56	6	240
700	RM0700U68	0.068	400	22.50	14.25	22.00	7.50	9.75	0.75	6	403
750	RM0750U15	0.015	209	18.00	8.25	14.00	6.00	6.25	0.563	6	159
750	RM0750U25	0.025	250	18.00	9.25	14.00	6.00	7.25	0.563	6	184
750	RM0750U36	0.036	293	18.00	9.75	14.00	6.00	7.75	0.563	6	236
750	RM0750U60	0.060	415	22.50	13.50	20.25	7.50	8.25	0.75	6	403
900	RM0900U13	0.013	216	18.00	12.00	14.00	6.00	7.25	0.56	6	159
900	RM0900U26	0.026	286	18.00	13.00	14.00	6.00	8.25	0.56	6	259
900	RM0900U32	0.032	400	18.00	13.63	14.00	6.00	10.25	0.75	6	340
900	RM0900U43	0.043	441	22.50	14.00	20.50	7.50	8.75	0.75	6	434
900	RM0900U53	0.053	490	22.50	13.00	21.50	7.50	10.25	0.75	6	546
1000	RM1000U11	0.011	179	18.00	12.50	18.00	6.00	9.25	0.75	6	200
1000	RM1000U18	0.018	232	22.50	13.75	20.50	7.50	11	0.75	6	282
1000	RM1000U29	0.029	377	22.50	13.75	20.50	7.50	7.25	0.75	6	394
1000	RM1000U38	0.038	416	22.50	14.00	20.50	7.50	10.25	0.56	6	450
1000	RM1000U48	0.048	490	22.50	15.00	20.50	7.50	11.25	0.75	6	642
1200	RM1200U10	0.010	228	18.00	13.50	14.00	6.00	8.25	0.563	6	205
1200	RM1200U15	0.015	287	18.00	14.00	18.50	6.00	10.75	0.75	6	300
1200	RM1200U18	0.018	395	18.00	14.25	18.38	7.50	8.25	0.75	6	343
1200	RM1200U24	0.024	440	22.50	14.00	20.50	7.50	9.25	0.75	6	444
1200	RM1200U30	0.030	490	22.50	14.00	17.00	7.50	10.25	0.75	6	534
1200	RM1200U40	0.040	576	22.50	17.00	19.50	7.50	11.75	0.563	6	600

SECTION 3



Standard Three Phase Line Reactor Enclosed Specification Charts

Current (Amps)	Part Number	Inductance	Watts Loss	Dimensions					Mtg Slot/ Hole Size	Dim. Fig. # (Page 117)	Case Style	Enclosed Weight (Lbs.)
				W	D	H	Mtg. W	Mtg. D				
2	RM0002M12E	12.0	7	10.00	8.00	8.00	7.00	6.50	0.188	1	N1	9
2	RM0002M20E	20.0	9	10.00	8.00	8.00	7.00	6.50	0.188	1	N1	10
2	RM0002M32E	32.0	13	10.00	8.00	8.00	7.00	6.50	0.188	1	N1	10
4	RM0004M12E	12.0	21	10.00	8.00	8.00	7.00	6.50	0.188	1	N1	11
4	RM0004M22E	22.0	25	10.00	8.00	8.00	7.00	6.50	0.188	3	N1	15
4	RM0004N30E	3.00	7	10.00	8.00	8.00	7.00	6.50	0.188	1	N1	9
4	RM0004N65E	6.50	13	10.00	8.00	8.00	7.00	6.50	0.188	1	N1	10
4	RM0004N91E	9.10	15	10.00	8.00	8.00	7.00	6.50	0.188	1	N1	10
8	RM0008N15E	1.50	11	10.00	8.00	8.00	7.00	6.50	0.188	1	N1	10
8	RM0008N30E	3.00	25	10.00	8.00	8.00	7.00	6.50	0.188	1	N1	10
8	RM0008N50E	5.00	31	10.00	8.00	8.00	7.00	6.50	0.188	1	N1	11
8	RM0008N75E	7.50	31	10.00	8.00	8.00	7.00	6.50	0.188	3	N1	16
12	RM0012N13E	1.30	23	10.00	8.00	8.00	7.00	6.50	0.188	1	N1	10
12	RM0012N25E	2.50	26	10.00	8.00	8.00	7.00	6.50	0.188	3	N1	15
12	RM0012N31E	3.10	30	10.00	8.00	8.00	7.00	6.50	0.188	3	N1	16
12	RM0012N42E	4.20	34	10.00	8.00	8.00	7.00	6.50	0.188	3	N1	17
12	RM0012N51E	5.10	39	10.00	8.00	8.00	7.00	6.50	0.188	3	N1	20
18	RM0018N15E	1.50	29	10.00	8.00	8.00	7.00	6.50	0.188	3	N1	16
18	RM0018N25E	2.50	40	10.00	8.00	8.00	7.00	6.50	0.188	2	N1	20
18	RM0018P80E	0.80	19	10.00	8.00	8.00	7.00	6.50	0.188	3	N1	14
25	RM0025N12E	1.20	44	10.00	8.00	8.00	7.00	6.50	0.188	2	N1	17
25	RM0025N20E	2.00	59	14.00	14.00	12.00	10.00	10.50	0.188	3	N2	35
25	RM0025P50E	0.50	23	10.00	8.00	8.00	7.00	6.50	0.188	2	N1	14
35	RM0035N12E	1.20	75	14.00	14.00	12.00	10.00	10.50	0.188	3	N2	43
35	RM0035N17E	1.70	90	14.00	14.00	12.00	10.00	10.50	0.188	3	N2	52
35	RM0035P40E	0.40	36	10.00	8.00	8.00	7.00	6.50	0.188	2	N1	16
35	RM0035P80E	0.80	51	14.00	14.00	12.00	10.00	10.50	0.188	3	N2	24
45	RM0045N12E	1.20	100	14.00	14.00	12.00	10.00	10.50	0.188	3	N2	52
45	RM0045P30E	0.30	33	10.00	8.00	8.00	7.00	6.50	0.188	2	N1	20
45	RM0045P70E	0.70	64	14.00	14.00	12.00	10.00	10.50	0.188	3	N2	39
55	RM0055P25E	0.25	39	10.00	8.00	8.00	7.00	6.50	0.188	2	N1	19
55	RM0055P50E	0.50	75	14.00	14.00	12.00	10.00	10.50	0.188	3	N2	43
55	RM0055P85E	0.85	110	14.00	14.00	12.00	10.00	10.50	0.188	3	N2	52
80	RM0080P20E	0.20	88	14.00	14.00	12.00	10.00	10.50	0.188	4	N2	43
80	RM0080P23E	0.23	70	14.00	14.00	12.00	10.00	10.50	0.188	4	N2	50
80	RM0080P40E	0.40	138	14.00	14.00	12.00	10.00	10.50	0.188	4	N2	53
80	RM0080P70E	0.70	140	14.00	14.00	12.00	10.00	10.50	0.188	4	N2	80
110	RM0110P15E	0.15	86	14.00	14.00	12.00	10.00	10.50	0.188	4	N2	44
110	RM0110P18E	0.18	95	14.00	14.00	12.00	10.00	10.50	0.188	4	N2	52
110	RM0110P30E	0.30	123	14.00	14.00	12.00	10.00	10.50	0.188	4	N2	69
110	RM0110P45E	0.45	130	14.00	14.00	12.00	10.00	10.50	0.188	4	N2	80
130	RM0130P10E	0.10	95	14.00	14.00	12.00	10.00	10.50	0.188	4	N2	44
130	RM0130P20E	0.20	115	14.00	14.00	12.00	10.00	10.50	0.188	4	N2	58
130	RM0130P30E	0.30	142	14.00	14.00	12.00	10.00	10.50	0.188	4	N2	70
130	RM0130P37E	0.37	143	14.00	14.00	12.00	10.00	10.50	0.188	4	N2	92
160	RM0160P15E	0.15	129	14.00	14.00	12.00	10.00	10.50	0.188	4	N2	63
160	RM0160P23E	0.23	142	14.00	14.00	12.00	10.00	10.50	0.188	4	N2	83
160	RM0160P32E	0.32	141	23.90	25.00	28.75	22.75	9.00	0.56	4	NH6	164
160	RM0160U75E	0.08	100	14.00	14.00	12.00	10.00	10.50	0.188	4	N2	46

Note: Please refer to Pages 260 to 264 for enclosure dimensional specifications



SECTION 3

Standard Three Phase Line Reactor Enclosed Specification Charts

Current (Amps)	Part Number	Inductance	Watts Loss	Dimensions					Mtg Slot/Hole Size	Dim. Fig. # (Page 117)	Case Style	Enclosed Weight (Lbs.)
				W	D	H	Mtg. W	Mtg. D				
200	RM0200P11E	0.11	114	23.90	25.00	28.75	22.75	9.00	0.56	4	NH6	112
200	RM0200P19E	0.190	138	23.90	25.00	28.75	22.75	9.00	0.56	4	NH6	153
200	RM0200P24E	0.240	164	19.40	20.20	21.50	18.00	9.00	0.56	4	NH5	165
200	RM0200U55E	0.055	89	14.00	14.00	12.00	10.00	10.50	0.188	4	N2	154
250	RM0250P15E	0.150	188	23.90	25.00	28.75	22.75	9.00	0.56	5	NH6	179
250	RM0250P19E	0.190	203	23.90	25.00	28.75	22.75	9.00	0.56	5	NH6	197
250	RM0250U45E	0.045	90	23.90	25.00	28.75	22.75	9.00	0.56	4	NH6	100
250	RM0250U90E	0.090	131	23.90	25.00	28.75	22.75	9.00	0.56	4	NH6	125
320	RM0320P13E	0.13	245	23.90	25.00	28.75	22.75	9.00	0.56	5	NH6	187
320	RM0320P16E	0.160	270	23.90	25.00	28.75	22.75	9.00	0.56	5	NH6	206
320	RM0320U40E	0.040	94	23.90	25.00	28.75	22.75	9.00	0.56	4	NH6	129
320	RM0320U75E	0.075	184	23.90	25.00	28.75	22.75	9.00	0.56	5	NH6	147
320	RM0320U96E	0.096	214	23.90	25.00	28.75	22.75	9.00	0.56	5	NH6	167
400	RM0400P11E	0.11	278	23.90	25.00	28.75	22.75	9.00	0.56	5	NH6	216
400	RM0400P14E	0.14	305	23.90	25.00	28.75	22.75	9.00	0.56	6	NH6	313
400	RM0400U30E	0.030	130	23.90	25.00	28.75	22.75	9.00	0.56	4	NH6	121
400	RM0400U61E	0.061	177	23.90	25.00	28.75	22.75	9.00	0.56	5	NH6	175
400	RM0400U82E	0.082	210	23.90	25.00	28.75	22.75	9.00	0.56	5	NH6	208
500	RM0500U25E	0.025	152	23.90	25.00	28.75	22.75	9.00	0.56	5	NH6	160
500	RM0500U50E	0.05	196	23.90	25.00	28.75	22.75	9.00	0.56	5	NH6	211
500	RM0500U57E	0.057	217	26.00	25.00	38.00	21.50	19.00	0.56	5	NH3	245
500	RM0500U85E	0.085	280	26.00	25.00	38.00	21.50	19.00	0.56	5	NH3	302
500	RM0500U96E	0.096	317	26.00	25.00	38.00	21.50	19.00	0.56	6	NH3	359
600	RM0600U20E	0.020	147	26.00	25.00	38.00	21.50	19.00	0.56	5	NH3	192
600	RM0600U40E	0.040	223	26.00	25.00	38.00	21.50	19.00	0.56	5	NH3	254
600	RM0600U65E	0.065	290	26.00	25.00	38.00	21.50	19.00	0.56	5	NH3	307
600	RM0600U80E	0.080	340	32.00	29.50	41.00	23.50	23.50	0.56	6	NH4	417
700	RM0700U41E	0.041	276	32.00	29.50	41.00	23.50	23.50	0.56	6	NH4	347
700	RM0700U68E	0.068	400	32.00	29.50	41.00	23.50	23.50	0.56	6	NH4	510
750	RM0750U15E	0.015	209	32.00	29.50	41.00	23.50	23.50	0.56	6	NH4	266
750	RM0750U25E	0.025	250	32.00	29.50	41.00	23.50	23.50	0.56	6	NH4	291
750	RM0750U36E	0.036	293	32.00	29.50	41.00	23.50	23.50	0.56	6	NH4	343
750	RM0750U60E	0.060	415	32.00	29.50	41.00	23.50	23.50	0.56	6	NH4	510
900	RM0900U13E	0.013	216	32.00	29.50	41.00	23.50	23.50	0.56	6	NH4	266
900	RM0900U26E	0.026	286	32.00	29.50	41.00	23.50	23.50	0.56	6	NH4	366
900	RM0900U32E	0.032	400	32.00	29.50	41.00	23.50	23.50	0.56	6	NH4	447
900	RM0900U43E	0.043	441	32.00	29.50	41.00	23.50	23.50	0.56	6	NH4	541
900	RM0900U53E	0.053	490	32.00	29.50	41.00	23.50	23.50	0.56	6	NH4	653
1000	RM1000U11E	0.011	179	32.00	29.50	41.00	23.50	23.50	0.56	6	NH4	277
1000	RM1000U18E	0.018	232	32.00	29.50	41.00	23.50	23.50	0.56	6	NH4	432
1000	RM1000U29E	0.029	377	39.50	34.00	51.50	24.00	32.00	0.69	6	NJ1	544
1000	RM1000U38E	0.038	416	26.00	25.00	38.00	21.50	19.00	0.56	6	NH3	684
1000	RM1000U48E	0.048	490	39.50	34.00	51.50	24.00	32.00	0.69	6	NJ1	792
1200	RM1200U10E	0.010	228	39.50	34.00	51.50	24.00	32.00	0.69	6	NJ1	355
1200	RM1200U15E	0.015	287	39.50	34.00	51.50	24.00	32.00	0.69	6	NJ1	432
1200	RM1200U18E	0.018	395	39.50	34.00	51.50	24.00	32.00	0.69	6	NJ1	493
1200	RM1200U24E	0.024	440	39.50	34.00	51.50	24.00	32.00	0.69	6	NJ1	594
1200	RM1200U30E	0.030	490	39.50	34.00	51.50	24.00	32.00	0.69	6	NJ1	684
1200	RM1200U40E	0.040	576	39.50	34.00	51.50	24.00	32.00	0.69	6	NJ1	850

SECTION 3

Note: Please refer to Pages 260 to 264 for enclosure dimensional specifications



Application and Connection Diagrams

INPUT SIDE OF DRIVE

Installed on the input side of drives, reactors will reduce line notching, limit current and voltage spikes and surges from the incoming line and will reduce harmonic distortion from the drive onto the line. Units are installed in front of the drive or inverter as shown.

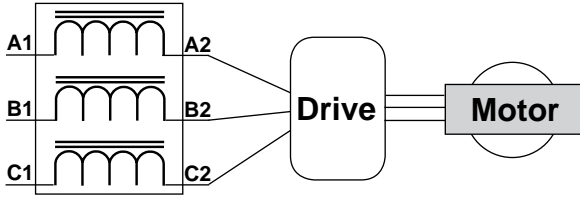

OUTPUT SIDE OF DRIVE

On the output side between the motor and the controller, reactors protect the controller from short circuits at the load. Motor performance improves. Voltage and current waveforms from the supply are enhanced reducing motor overheating and noise emissions.

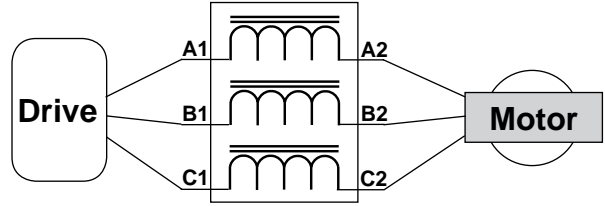

MULTIPLE DRIVES

Individual line reactors are recommended when multiple drives are installed on the same power line. Individual reactors eliminates cross talk between multiple drives and provides isolated protection for each controller for its own specific load.

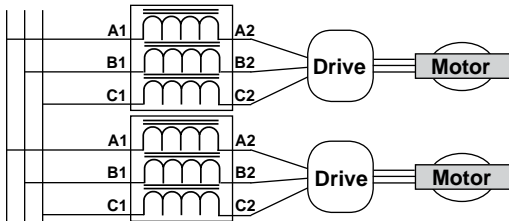

MULTIPLE MOTORS

A single reactor can be installed when the application calls for multiple motors on the same drive. The reactor is sized based on the total horsepower of all the motors. Recommended for simultaneous operating motors only.

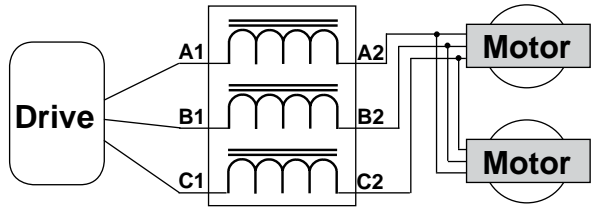

Termination Details

CONNECTOR DETAIL		
Open Style Ref.	Type	Range/Dia.
Figure #1	Terminal Block	#12 - #22
Figure #2	Terminal Block	#4 - #18
Figure #3	Terminal Block	#4 - #18
<u>All Others:</u>		
80 to 200 amps	Terminal Pad	.313" dia. (diagram 1A)
Above 200 amps	Terminal Pad	.5" dia. (diagram 1B)

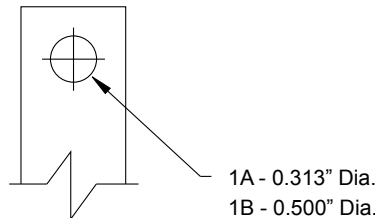

DIAGRAM 1

RM Line Reactor Cross-Reference Table

MTE Part Number	Current (Amps)	HPS Part Number	Induct. (mH)	TCI Part Number
RL-00201	2	RM0002M12	12.000	KLR2A
RL-00202	2	RM0002M20	20.000	KLR2C
RL-00203	2	RM0002M32	32.000	*
RL-00404	4	RM0004M12	12.000	*
RL-00401	4	RM0004N30	3.000	KLR4B
RL-00402	4	RM0004N65	6.500	KLR4A
RL-00403	4	RM0004N91	9.100	KLR4C
RL-00801	8	RM0008N15	1.500	KLR8B
RL-00802	8	RM0008N30	3.000	KLR8A
RL-00803	8	RM0008N50	5.000	KLR8C
RL-00804	8	RM0008N75	7.500	*
RL-01201	12	RM0012N13	1.300	KLR12B
RL-01202	12	RM0012N25	2.500	KLR12A
RL-01203	12	RM0012N42	4.200	KLR12C
RL-01802	18	RM0018N15	1.500	KLR16A
RL-01803	18	RM0018N25	2.500	KLR16C
RL-01801	18	RM0018P80	0.800	KLR16B
RL-02502	25	RM0025N12	1.200	KLR25A
RL-02503	25	RM0025N20	2.000	KLR25C
RL-02501	25	RM0025P50	0.500	KLR25B
RL-03503	35	RM0035N12	1.200	KLR35C
RL-03501	35	RM0035P40	0.400	KLR35B
RL-03502	35	RM0035P80	0.800	KLR35A
RL-04503	45	RM0045N12	1.200	KLR45C
RL-04501	45	RM0045P30	0.300	KLR45B
RL-04502	45	RM0045P70	0.700	KLR45A
RL-05501	55	RM0055P25	0.250	KLR55B
RL-05502	55	RM0055P50	0.500	KLR55A
RL-05503	55	RM0055P85	0.850	KLR55C

MTE Part Number	Current (Amps)	HPS Part Number	Induct. (mH)	TCI Part Number
RL-08001	80	RM0080P20	0.200	KLR80B
RL-08002	80	RM0080P40	0.400	KLR80A
RL-08003	80	RM0080P70	0.700	KLR80C
RL-10001	100	RM0110P15	0.150	KLR110B
RL-10002	100	RM0110P30	0.300	KLR110A
RL-10003	100	RM0110P45	0.450	KLR110C
RL-13001	130	RM0130P10	0.100	KLR130B
RL-13002	130	RM0130P20	0.200	KLR130A
RL-13003	130	RM0130P30	0.300	KLR130C
RL-16002	160	RM0160P15	0.150	KLR160A
RL-16003	160	RM0160P23	0.230	KLR160C
RL-16001	160	RM0160U75	0.075	KLR160B
RL-20002	200	RM0200P11	0.110	KLR200A
RL-20003	200	RM0200P19	0.190	KLR200C
RL-20001	200	RM0200U55	0.055	KLR200B
RL-25003	250	RM0250P15	0.150	KLR250C
RL-25001	250	RM0250U45	0.045	KLR250B
RL-25002	250	RM0250U90	0.090	KLR250A
RL-32003	320	RM0320P13	0.130	KLR300C
RL-32001	320	RM0320U40	0.040	KLR300B
RL-32002	320	RM0320U75	0.075	KLR300A
RL-40003	400	RM0400P11	0.110	KLR360C
RL-40001	400	RM0400U30	0.030	KLR360B
RL-40002	400	RM0400U61	0.061	KLR360A
RL-50001	500	RM0500U25	0.025	KLR480B
RL-50002	500	RM0500U50	0.050	KLR480A
RL-50003	500	RM0500U85	0.085	KLR480C
RL-60001	600	RM0600U20	0.020	KLR600B
RL-60002	600	RM0600U40	0.040	KLR600A
RL-60003	600	RM0600U65	0.065	KLR600C



DV/DT Filters

The advent of pulse width modulated (PWM) inverters with IGBT high speed transistors has resulted in smaller more cost effective drives and increased switching speeds. A waveform with increased harmonics at higher frequencies is the result of these much faster switching devices, usually at frequencies of 10,000 to 20,000 Hertz.

Drives and motors often need to be separated by significant distances. For deep wells or mines, the motors are usually controlled on the surface. As a result, the distance between the drive and the motor creates long motor lead lengths. In some plant applications, the motors can withstand the harsh environment, but the sensitive variable frequency drive cannot. This again results in long lead lengths to the motor.

Most manufactures of variable frequency drives will publish a recommended maximum distance between their equipment and the motor. Sometimes these recommendations create application difficulties, thus increased motor lead lengths are inevitable.

DV/DT is explained as the steep-front voltage pulses that travel down these long leads in the circuit to the motor and subsequently reverted back in a “reflective wave”. When the conductors are long enough, usually 20 feet or more, the time for reflection matches the time for transmission resulting in a high amplitude ‘standing wave’ on the circuit. Voltage spikes of up to 2100 volts are frequently experienced for 600 volt systems and motor winding failures are the result.

A DV/DT filter, combines the current limiting ability of an AC line reactor plus a resistive capacitance circuit that forms a damped, low pass filter. It provides protection for the motor by slowing the rate of voltage increase and minimizing the peak voltage that occurs at the motor terminals.

The cost of a DV/DT Filter is a little more than the cost of the reactor and can be mounted next to the drive, or inside the PWM enclosure.

APPLICATIONS

The HPS RC series DV/DT filters are specifically designed for drive/motor applications with long lead lengths (usually where the motor cable length is 20 feet and greater). They should always be installed next to the IGBT variable frequency drive. Typical installation applications include production process lines, conveyor systems and deep wells.

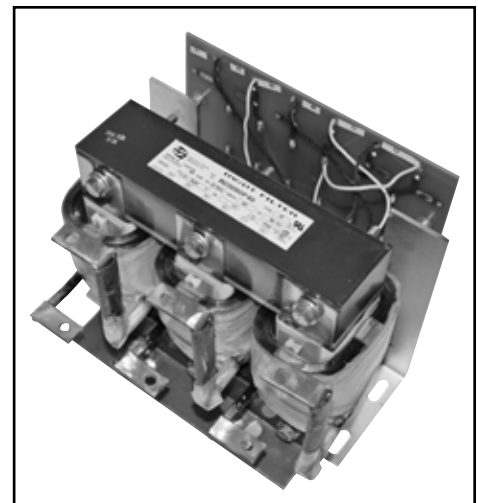
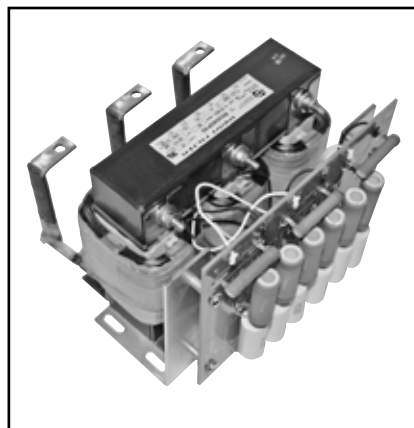
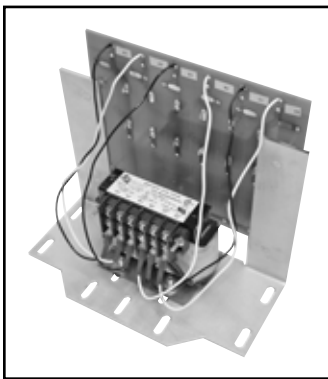

TYPICAL “RC” DV/DT FILTERS PERFORMANCE

The RC series DV/DT filters combine appropriate values of inductance, capacitance and resistance to form a filter which reduces DV/DT and peak voltages from the PWM voltage waveform. This combined with a 3% impedance reactor, that will reduce motor heating harmonics, will significantly increase the life of the motor.

Long lead length motor drive applications can experience motor terminal peak voltage spikes twice the DC bus voltage, and higher. Therefore motor terminal voltage peaks of 1200 volts for 480V drives and 1600 volts for 600V drives are not uncommon. The highest peak voltages will typically occur in lower HP applications.

Standard “RC” DV/DT Filter Specifications

RATINGS:

Nominal Inductance +/- 10% @ rated current.
95% of nominal inductance @ 150% rated current.
50% of nominal inductance @ 350% of rated current.

The above performance indicates that even at very substantial overload conditions (even beyond what other equipment in the circuit could tolerate), the RM Line Reactor will still provide current limiting performance against total harmonic distortion generated by the drive system.

TEMPERATURE RISE:

115° C on units up to 160 amps; average ambient of 40° C.

115° C on units larger than 160 amps; average ambient of 60° C.

INSULATION SYSTEM:

200° C Temperature Class up to 160 amps
220° C Temperature Class over 160 amps

FREQUENCY:

60 Hz Fundamental Current Maximum.

COOLING METHOD:

Natural convection

SYSTEM VOLTAGE:

600 Volts Maximum

APPROVALS:

UL File No.: E61431

CSA File No.: LR 3902

SOUND LEVEL:

2 to 18 amps:	58 dBA
130 to 320 amps:	70 dBA
25 to 100 amps:	64 dBA
400 to 600 amps:	75 dBA

ENCLOSURE: (when specified)

NEMA 2 or NEMA 3R

HARMONIC WITHSTAND:

Hammond DV/DT filters are designed to withstand harmonics associated with the output side of variable speed drives including IGBT type inverters.

SWITCHING FREQUENCY:

2.5 KHz up to 20 KHz.



“RC” DV/DT Filter Selection

SELECTION GUIDELINES

HPS RC filters are current rated devices. Therefore, to properly size and select the correct unit for your application, it is necessary to know the total motor load on the inverter. All RC filters are designed to be located next to the output terminals of the drive with symmetrical configured *three phase* cable used to connect the RC filter to the motor. Placement of these filters anywhere else will negatively impact the units performance.

The DV/DT filters have had the reactor selected in such a manner that the 3% impedance is approximately maintained at both the 600 and 480 system voltage level. Utilizing a 3% reactor provides optimum performance and protection for the motor. Using smaller impedance reactors will not protect against the same current peaks and motor performance would therefore be diminished.

DV/DT Filter Part Number Guide

RC 0002 M 32 * _

↑ ↑ ↑ ↑ ↑

Further suffix to follow.
Add suffix “E” for Enclosure.
Inductance Value
The inductance value is preceded with a letter to designate the position of the decimal point to determine the inductance. The letters are as follows:
'M' XX. mH
'N' X.X mH
'P' 0.XX mH
'U' .0XX mH or XX.0 uH
Example: M32 is 32.0 mH
4 digits for current rating DV/DT Filter

Note: As all characters of the P/N represent performance values of the reactor, P/N's are not completely sequential. They are sorted by current rating.

* Add the Suffix “E” to the standard part number below for an Enclosed unit.

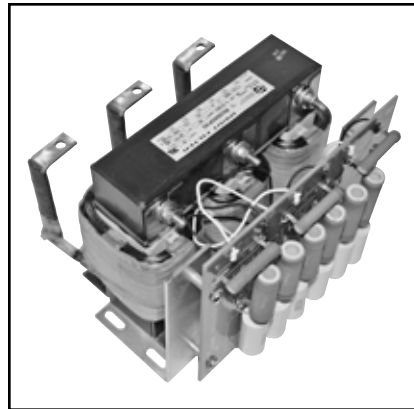

“RC” DV/DT FILTER SELECTION TABLE FOR 600V OR 480V, 3% IMPEDANCE, 60 Hz

Current (Amps)	Part Number	Inductance	Watts Loss	Dimensions					Mtg Slot/Hole Size	Dim. Fig. # (Page 118)	Encl. Fig. #	Weight (Lbs.)	Enclosed Weight (Lbs.)
				W	D	H	Mtg. W	Mtg. D					
2	RC0002M12	12.0	62	9.00	6.18	7.40	8.25	2	.28 x .88	7	N1	4	11
4	RC0004N65	6.50	68	9.00	6.18	7.40	8.25	2	.28 x .88	7	N1	5	12
8	RC0008N30	3.00	80	9.00	6.18	7.40	8.25	2	.28 x .88	7	N1	5	12
12	RC0012N25	2.50	81	9.00	6.18	7.40	8.25	2	.28 x .88	8	N1	10	17
18	RC0018N15	1.50	84	9.00	6.18	7.40	8.25	2	.28 x .88	8	N1	11	18
25	RC0025N12	1.20	99	9.00	6.18	7.40	8.25	2	.28 x .88	8	N1	12	19
35	RC0035P80	0.80	106	9.00	6.18	7.40	8.25	2	.28 x .88	9	N2	19	36
45	RC0045P70	0.70	119	9.00	6.42	7.40	8.25	2	.28 x .88	9	N2	24	41
55	RC0055P50	0.50	130	9.00	6.27	7.40	8.25	2	.28 x .88	10	N2	28	45
80	RC0080P40	0.40	193	9.00	7.83	7.40	8.25	2	.28 x .88	10	N2	38	55
110	RC0110P30	0.30	423	14.0	8.70	11.62	3.6/4.8	4.20	.44 X 1.25	11	NH5	55	95
130	RC0130P20	0.20	415	14.0	8.20	11.62	3.6/4.8	3.73	.44 X 1.25	11	NH5	44	88
160	RC0160P15	0.15	429	14.0	8.70	11.62	3.6/4.8	4.23	.44 X 1.25	11	NH5	49	89
200	RC0200P11	0.11	414	14.0	9.23	11.62	3.6/4.8	4.23	.44 X 1.25	11	NH6	55	115
250	RC0250U90	0.090	431	14.0	9.73	11.62	3.6/4.8	4.70	.44 X 1.25	11	NH6	68	128
320	RC0320U75	0.075	484	14.4	9.50	11.43	4.80	5.94	.44 X 1.00	12	NH6	90	150
400	RC0400U61	0.061	477	14.4	11.5	11.43	4.80	6.44	.44 X 1.00	12	NH6	118	178
500	RC0500U50	0.05	496	14.4	11.5	11.43	4.80	6.44	.44 X 1.00	12	NH3	154	231
600	RC0600U40	0.040	523	14.4	12.0	11.43	4.80	6.94	.44 X 1.00	12	NH4	180	287

Note: Please refer to pages 260 to 264 for enclosure dimensional specifications

Open Style "RM" Reference Drawings

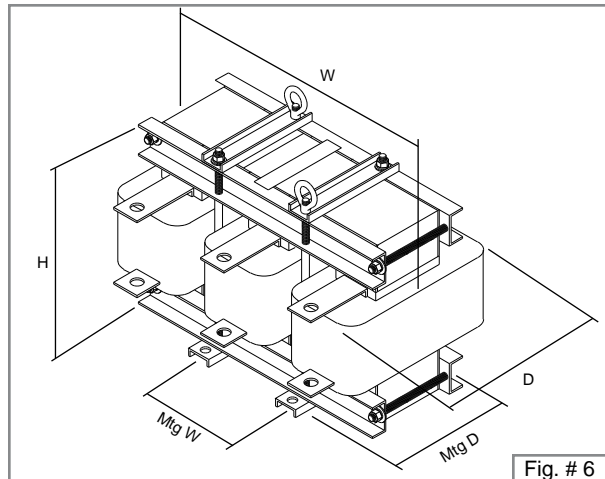
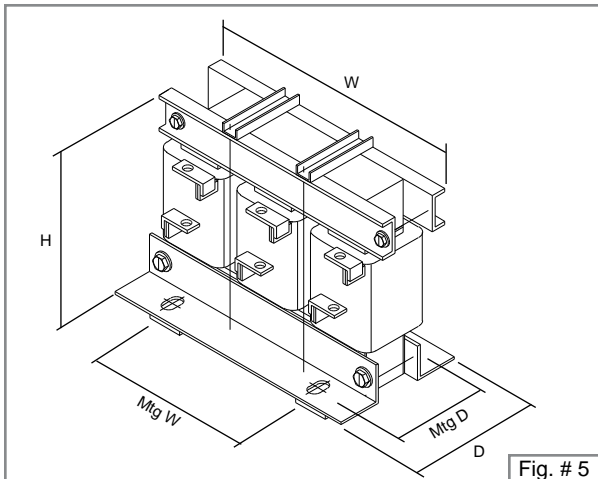
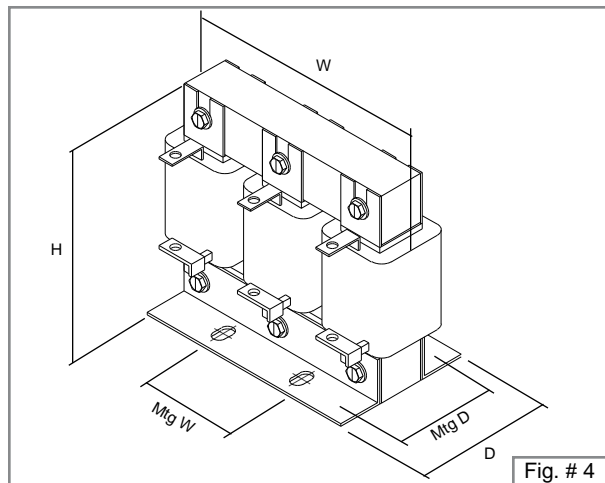
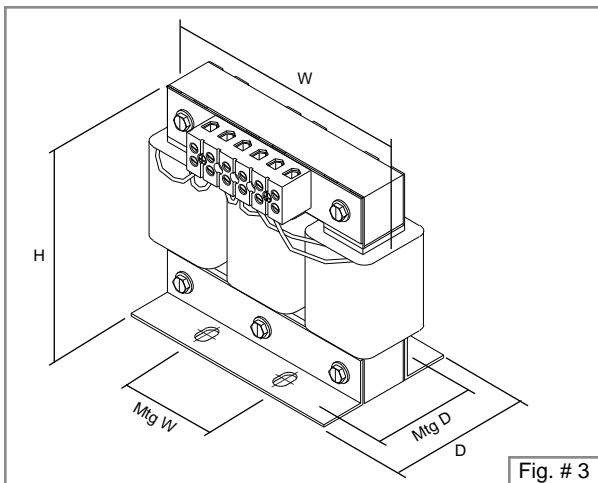
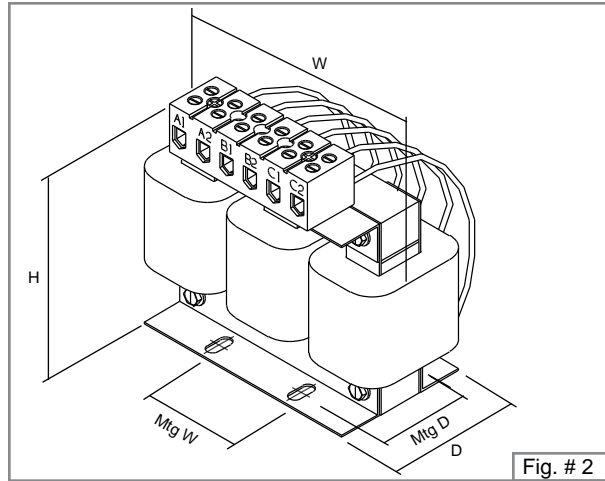
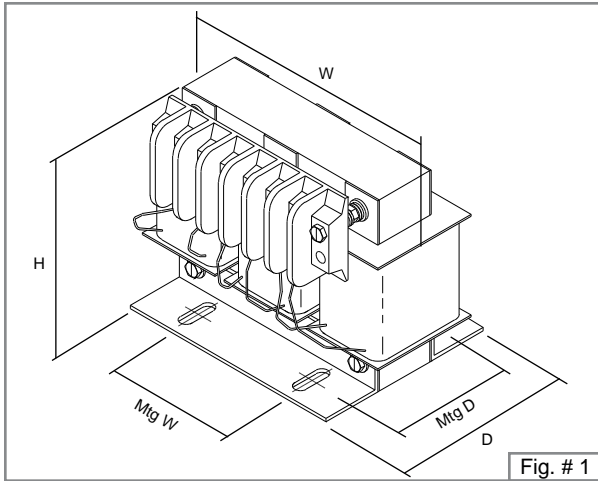

SECTION 3

Open Style "RC" Reference Drawings

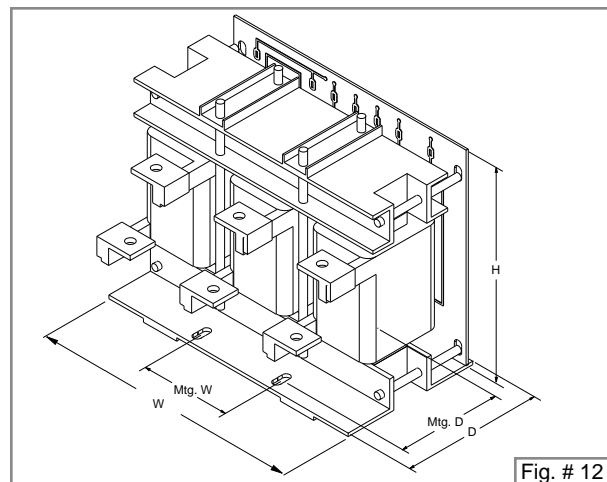
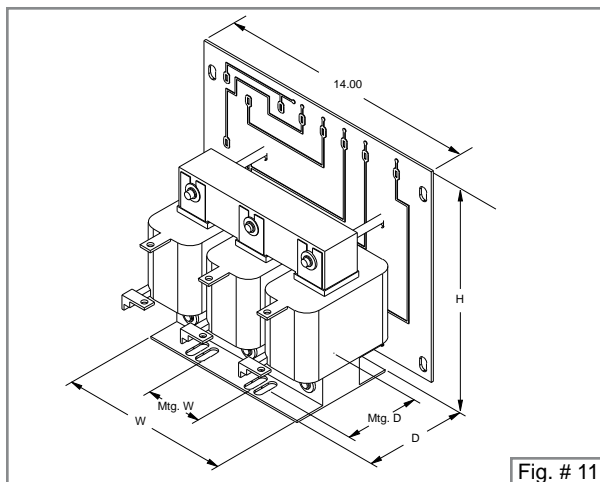
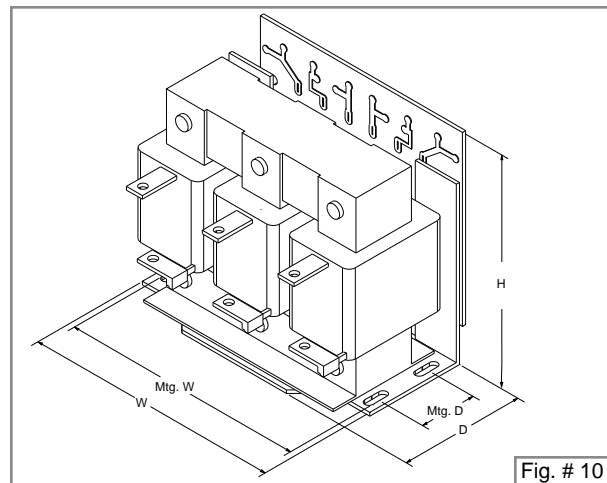
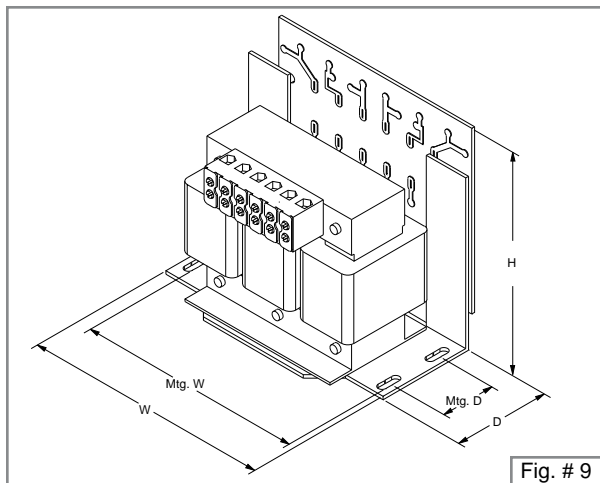
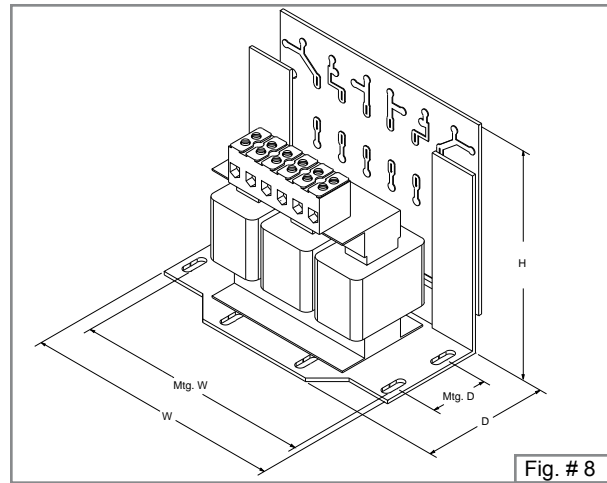
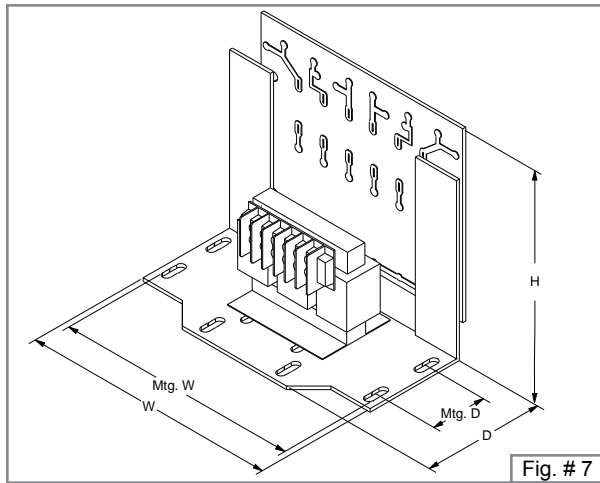

SECTION 3



SECTION 4

STANDARD & ENERGY EFFICIENT DRIVE ISOLATION TRANSFORMERS

Aluminum and Copper Wound Three Phase

Description and Applications	120
Selecting Drive Isolation Transformers	120
<u>Standard Drive Isolation Transformers:</u>	
Standard Aluminum and Copper Specifications	121
Standard Aluminum Selection Tables	122
Standard Copper Selection Tables	126
Termination Details	131
<u>HPS Tribune Energy Efficient Drive Isolation Transformers:</u>	
HPS Tribune - Aluminum and Copper Standard Specifications	132
HPS Tribune - Aluminum Selection Tables	133
HPS Tribune - Copper Selection Tables	137
Termination Details	142
Enclosure Drawings	260
Accessories - Enclosure Mounting Kits, Anti-Vibration Pads & Isolators ..	271
Electrical Schematics and Connections	276

THREE PHASE, DRIVE ISOLATION TRANSFORMERS

With today's technological advances in solid-state power control devices, the use of AC and DC variable speed drives has proliferated in many industrial markets. General purpose distribution transformers are not adequate for this type of application.

HPS Drive Isolation Transformers are designed to meet the rugged demands of both AC and DC variable speed drives and also to provide the required voltage change. The separate primary and secondary windings provide electrical isolation between the incoming line and the SCR load. The windings are designed to withstand overcurrent of 150% of the rated load for 60 seconds or 200% of the rated load for 30 seconds. (A duty cycle of one start for every two hours is permitted.)

Drive Isolation Transformers are sized to match standard motor horsepower and voltage ratings. Standard sizes range from 5 to 600 HP in six standard voltages. Non-standard sizes and voltages are available upon request.



SELECTION INSTRUCTIONS

Select the Drive Isolation Transformer according to the recommendations from the motor drive system manufacturer or supplier. If this information is unavailable, use the table below as a guide for selecting the transformer kVA for a required motor horsepower.

Motor H.P.	Transformer kVA
5	7.5
7.5	11
10	14
15	20
20	27
25	34
30	40
40	51
50	63
60	75

Motor H.P.	Transformer kVA
75	93
100	118
125	145
150	175
200	220
250	275
300	330
400	440
500	550
600	660

FOR TERMINATION DETAILS SEE PAGE 131

FOR ACCESSORIES SEE PAGES 271 TO 274



ALUMINUM AND COPPER WOUND FEATURES

THREE PHASE STANDARD SPECIFICATIONS



	7.5 to 175 kVA	220 to 660 kVA
UL Listed	File: E112313	File: E112313
CSA Certified	File: LR3902	File: LR3902
Frequency	60 Hz	60 Hz
Insulation System	220°C (150°C rise) 200°C (130°C rise) on some Copper units up to 40kVA	220°C (150°C rise) (Optional 115°C and 80°C rise available)
Enclosure Type	Heavy Duty Ventilated NEMA Type 3R Optional NEMA 4, 4X(stainless steel) and 12	Heavy Duty Ventilated NEMA Type 3R Optional NEMA 4, 4X(stainless steel) and 12
Enclosure Finish	ANSI 61 Grey, UL50	ANSI 61 Grey, UL50
Neutral	Neutral terminal for field connection (on applicable units).	Neutral terminal for field connection (on applicable units).
Standard Primary Taps	Refer to wiring diagrams for details.	Refer to wiring diagrams for details.
Termination	Front accessible separate high and low voltage terminations; suitable for copper and aluminum are provided for easy cable installation.	Front accessible separate high and low voltage terminations, suitable for copper and aluminum are provided for easy cable installation.
Thermostat	Standard on all units.	Standard on all units.
Conduit Knock-Outs	Standard on all units.	None
Impedance	Typically 3 to 6%	Typically 3 to 6%
Mounting	Floor mounting available on all units. Wall & ceiling mount available on units up to 750 lbs. Refer to selection tables for details.	Floor mounting only.
Seismic	Meets Occupancy Category III $I_p=1.25$ for $S_s=1.0g$ per IBC 2006; section 1613, earthquake loads and NBCC 2005 for ground level installations only for all locations in North America.	Meets Occupancy Category III $I_p=1.25$ for $S_s=1.0g$ per IBC 2006; section 1613, earthquake loads and NBCC 2005 for ground level installations only for all locations in North America.
Short Circuit Withstand	Meets UL and CSA short circuit withstand requirements.	Meets UL and CSA short circuit withstand requirements.

SECTION 4

Selection Tables



Listed below are our standard voltages. Other primary and secondary voltages available are 240, 380 and 600.

ALUMINUM WOUND, THREE PHASE

208 Delta Primary Volts

480Y Secondary Volts

60 Hz

kVA	Catalog Number	Case Style (Pages 260 - 267)	Dimensions			Approx. Weight (Lbs.)	Mtg Type W - Wall F - Floor	Wiring Diagram (Pages 276 - 288)
			Width	Depth	Height			
7.5	DM007BK	NH5	19.40	20.20	21.50	150	F or W *	SCD 8
11	DM011BK	NH5	19.40	20.20	21.50	160	F or W *	SCD 8
14	DM014BK	NH5	19.40	20.20	21.50	170	F or W *	SCD 8
20	DM020BK	NH6	23.90	25.00	28.75	240	F or W *	SCD 7
27	DM027BK	NH6	23.90	25.00	28.75	300	F or W *	SCD 7
34	DM034BK	NH6	23.90	25.00	28.75	330	F or W *	SCD 7
40	DM040BK	NH6	23.90	25.00	28.75	350	F or W *	SCD 7
51	DM051BK	NH6	23.90	25.00	28.75	430	F or W *	SCD 7
63	DM063BK	NH3	26.00	25.00	38.00	530	F or W *	SCD 7
75	DM075BK	NH3	26.00	25.00	38.00	580	F or W *	SCD 7
93	DM093BK	NH3	26.00	25.00	38.00	630	F or W *	SCD 7
118	DM118BK	NH3	26.00	25.00	38.00	730	F or W *	SCD 7
145	DM145BK	NH4	32.00	29.50	41.00	830	F	SCD 7
175	DM175BK	NH4	32.00	29.50	41.00	930	F	SCD 7
220	DM220BK	NH4	32.00	29.50	41.00	1350	F	SCD 9
275	DM275BK	NJ1	39.50	34.00	51.50	1500	F	SCD 9
330	DM330BK	NJ1	39.50	34.00	51.50	1700	F	SCD 9
440	DM440BK	NJ2	48.50	38.40	59.00	2100	F	SCD 10
550	DM550BK	NJ2	48.50	38.40	59.00	2350	F	SCD 10
660	DM660BK	NJ3	51.50	43.40	66.00	2900	F	SCD 10

For shielded units, please add the suffix "S" to the above part numbers. (i.e. DM075BKS)

*WALL MOUNTING KIT AND/OR DRIP PLATE KIT REQUIRED. REFER TO PAGES 271 TO 273 FOR DETAILS.

230 Delta Primary Volts

230Y Secondary Volts

60 Hz

kVA	Catalog Number	Case Style (Pages 260 - 267)	Dimensions			Approx. Weight (Lbs.)	Mtg Type W - Wall F - Floor	Wiring Diagram (Pages 276 - 288)
			Width	Depth	Height			
7.5	DM007CC	NH5	19.40	20.20	21.50	150	F or W *	SCD 8
11	DM011CC	NH5	19.40	20.20	21.50	160	F or W *	SCD 8
14	DM014CC	NH5	19.40	20.20	21.50	170	F or W *	SCD 8
20	DM020CC	NH6	23.90	25.00	28.75	240	F or W *	SCD 7
27	DM027CC	NH6	23.90	25.00	28.75	300	F or W *	SCD 7
34	DM034CC	NH6	23.90	25.00	28.75	330	F or W *	SCD 7
40	DM040CC	NH6	23.90	25.00	28.75	350	F or W *	SCD 7
51	DM051CC	NH6	23.90	25.00	28.75	430	F or W *	SCD 7
63	DM063CC	NH3	26.00	25.00	38.00	530	F or W *	SCD 7
75	DM075CC	NH3	26.00	25.00	38.00	580	F or W *	SCD 7
93	DM093CC	NH3	26.00	25.00	38.00	630	F or W *	SCD 7
118	DM118CC	NH3	26.00	25.00	38.00	730	F or W *	SCD 7
145	DM145CC	NH4	32.00	29.50	41.00	830	F	SCD 7
175	DM175CC	NH4	32.00	29.50	41.00	930	F	SCD 7
220	DM220CC	NH4	32.00	29.50	41.00	1350	F	SCD 9
275	DM275CC	NJ1	39.50	34.00	51.50	1500	F	SCD 9
330	DM330CC	NJ1	39.50	34.00	51.50	1700	F	SCD 9
440	DM440CC	NJ2	48.50	38.40	59.00	2100	F	SCD 10
550	DM550CC	NJ2	48.50	38.40	59.00	2350	F	SCD 10
660	DM660CC	NJ3	51.50	43.40	66.00	2900	F	SCD 10

For shielded units, please add the suffix "S" to the above part numbers. (i.e. DM075CCS)

*WALL MOUNTING KIT AND/OR DRIP PLATE KIT REQUIRED. REFER TO PAGES 271 TO 273 FOR DETAILS.

Products listed on this page are available as 'CE Mark' products. Please consult our sales office.

FOR TERMINATION DETAILS SEE PAGE 131

FOR ACCESSORIES SEE PAGES 271 TO 274



SECTION 4

Selection Tables



Listed below are our standard voltages. Other primary and secondary voltages available are 240, 380 and 600.

ALUMINUM WOUND, THREE PHASE

460 Delta Primary Volts

230Y Secondary Volts

60 Hz

kVA	Catalog Number	Case Style (Pages 260 - 267)	Dimensions			Approx. Weight (Lbs.)	Mtg Type W - Wall F - Floor	Wiring Diagram (Pages 276 - 288)
			Width	Depth	Height			
7.5	DM007JC	NH5	19.40	20.20	21.50	150	F or W *	SCD 8
11	DM011JC	NH5	19.40	20.20	21.50	160	F or W *	SCD 8
14	DM014JC	NH5	19.40	20.20	21.50	170	F or W *	SCD 8
20	DM020JC	NH6	23.90	25.00	28.75	240	F or W *	SCD 7
27	DM027JC	NH6	23.90	25.00	28.75	300	F or W *	SCD 7
34	DM034JC	NH6	23.90	25.00	28.75	330	F or W *	SCD 7
40	DM040JC	NH6	23.90	25.00	28.75	350	F or W *	SCD 7
51	DM051JC	NH6	23.90	25.00	28.75	430	F or W *	SCD 7
63	DM063JC	NH3	26.00	25.00	38.00	530	F or W *	SCD 7
75	DM075JC	NH3	26.00	25.00	38.00	580	F or W *	SCD 7
93	DM093JC	NH3	26.00	25.00	38.00	630	F or W *	SCD 7
118	DM118JC	NH3	26.00	25.00	38.00	730	F or W *	SCD 7
145	DM145JC	NH4	32.00	29.50	41.00	830	F	SCD 7
175	DM175JC	NH4	32.00	29.50	41.00	930	F	SCD 7
220	DM220JC	NH4	32.00	29.50	41.00	1350	F	SCD 9
275	DM275JC	NJ1	39.50	34.00	51.50	1500	F	SCD 9
330	DM330JC	NJ1	39.50	34.00	51.50	1700	F	SCD 9
440	DM440JC	NJ2	48.50	38.40	59.00	2100	F	SCD 10
550	DM550JC	NJ2	48.50	38.40	59.00	2350	F	SCD 10
660	DM660JC	NJ3	51.50	43.40	66.00	2900	F	SCD 10

For shielded units, please add the suffix "S" to the above part numbers. (i.e. DM075JCS)

*WALL MOUNTING KIT AND/OR DRIP PLATE KIT REQUIRED. REFER TO PAGES 271 TO 273 FOR DETAILS.

460 Delta Primary Volts

400Y Secondary Volts

60 Hz

kVA	Catalog Number	Case Style (Pages 260 - 267)	Dimensions			Approx. Weight (Lbs.)	Mtg Type W - Wall F - Floor	Wiring Diagram (Pages 276 - 288)
			Width	Depth	Height			
7.5	DM007JH	NH5	19.40	20.20	21.50	150	F or W *	SCD 8
11	DM011JH	NH5	19.40	20.20	21.50	160	F or W *	SCD 8
14	DM014JH	NH5	19.40	20.20	21.50	170	F or W *	SCD 8
20	DM020JH	NH6	23.90	25.00	28.75	240	F or W *	SCD 7
27	DM027JH	NH6	23.90	25.00	28.75	300	F or W *	SCD 7
34	DM034JH	NH6	23.90	25.00	28.75	330	F or W *	SCD 7
40	DM040JH	NH6	23.90	25.00	28.75	350	F or W *	SCD 7
51	DM051JH	NH6	23.90	25.00	28.75	430	F or W *	SCD 7
63	DM063JH	NH3	26.00	25.00	38.00	530	F or W *	SCD 7
75	DM075JH	NH3	26.00	25.00	38.00	580	F or W *	SCD 7
93	DM093JH	NH3	26.00	25.00	38.00	630	F or W *	SCD 7
118	DM118JH	NH3	26.00	25.00	38.00	730	F or W *	SCD 7
145	DM145JH	NH4	32.00	29.50	41.00	830	F	SCD 7
175	DM175JH	NH4	32.00	29.50	41.00	930	F	SCD 7
220	DM220JH	NH4	32.00	29.50	41.00	1350	F	SCD 9
275	DM275JH	NJ1	39.50	34.00	51.50	1500	F	SCD 9
330	DM330JH	NJ1	39.50	34.00	51.50	1700	F	SCD 9
440	DM440JH	NJ2	48.50	38.40	59.00	2100	F	SCD 10
550	DM550JH	NJ2	48.50	38.40	59.00	2350	F	SCD 10
660	DM660JH	NJ3	51.50	43.40	66.00	2900	F	SCD 10

For shielded units, please add the suffix "S" to the above part numbers. (i.e. DM075JHS)

*WALL MOUNTING KIT AND/OR DRIP PLATE KIT REQUIRED. REFER TO PAGES 271 TO 273 FOR DETAILS.

Products listed on this page are available as 'CE Mark' products. Please consult our sales office.

FOR TERMINATION DETAILS SEE PAGE 131

FOR ACCESSORIES SEE PAGES 271 TO 274



Selection Tables



Listed below are our standard voltages. Other primary and secondary voltages available are 240, 380 and 600.

ALUMINUM WOUND, THREE PHASE

460 Delta Primary Volts

460Y Secondary Volts

60 Hz

kVA	Catalog Number	Case Style (Pages 260 - 267)	Dimensions			Approx. Weight (Lbs.)	Mtg Type W - Wall F - Floor	Wiring Diagram (Pages 276 - 288)
			Width	Depth	Height			
7.5	DM007JJ	NH5	19.40	20.20	21.50	150	F or W *	SCD 8
11	DM011JJ	NH5	19.40	20.20	21.50	160	F or W *	SCD 8
14	DM014JJ	NH5	19.40	20.20	21.50	170	F or W *	SCD 8
20	DM020JJ	NH6	23.90	25.00	28.75	240	F or W *	SCD 7
27	DM027JJ	NH6	23.90	25.00	28.75	300	F or W *	SCD 7
34	DM034JJ	NH6	23.90	25.00	28.75	330	F or W *	SCD 7
40	DM040JJ	NH6	23.90	25.00	28.75	350	F or W *	SCD 7
51	DM051JJ	NH6	23.90	25.00	28.75	430	F or W *	SCD 7
63	DM063JJ	NH3	26.00	25.00	38.00	530	F or W *	SCD 7
75	DM075JJ	NH3	26.00	25.00	38.00	580	F or W *	SCD 7
93	DM093JJ	NH3	26.00	25.00	38.00	630	F or W *	SCD 7
118	DM118JJ	NH3	26.00	25.00	38.00	730	F or W *	SCD 7
145	DM145JJ	NH4	32.00	29.50	41.00	830	F	SCD 7
175	DM175JJ	NH4	32.00	29.50	41.00	930	F	SCD 7
220	DM220JJ	NH4	32.00	29.50	41.00	1350	F	SCD 9
275	DM275JJ	NJ1	39.50	34.00	51.50	1500	F	SCD 9
330	DM330JJ	NJ1	39.50	34.00	51.50	1700	F	SCD 9
440	DM440JJ	NJ2	48.50	38.40	59.00	2100	F	SCD 10
550	DM550JJ	NJ2	48.50	38.40	59.00	2350	F	SCD 10
660	DM660JJ	NJ3	51.50	43.40	66.00	2900	F	SCD 10

For shielded units, please add the suffix "S" to the above part numbers. (i.e. DM075JJS)

*WALL MOUNTING KIT AND/OR DRIP PLATE KIT REQUIRED. REFER TO PAGES 271 TO 273 FOR DETAILS.

480 Delta Primary Volts

240Y Secondary Volts

60 Hz

kVA	Catalog Number	Case Style (Pages 260 - 267)	Dimensions			Approx. Weight (Lbs.)	Mtg Type W - Wall F - Floor	Wiring Diagram (Pages 276 - 288)
			Width	Depth	Height			
7.5	DM007KD	NH5	19.40	20.20	21.50	150	F or W *	SCD 8
11	DM011KD	NH5	19.40	20.20	21.50	160	F or W *	SCD 8
14	DM014KD	NH5	19.40	20.20	21.50	170	F or W *	SCD 8
20	DM020KD	NH6	23.90	25.00	28.75	240	F or W *	SCD 7
27	DM027KD	NH6	23.90	25.00	28.75	300	F or W *	SCD 7
34	DM034KD	NH6	23.90	25.00	28.75	330	F or W *	SCD 7
40	DM040KD	NH6	23.90	25.00	28.75	350	F or W *	SCD 7
51	DM051KD	NH6	23.90	25.00	28.75	430	F or W *	SCD 7
63	DM063KD	NH3	26.00	25.00	38.00	530	F or W *	SCD 7
75	DM075KD	NH3	26.00	25.00	38.00	580	F or W *	SCD 7
93	DM093KD	NH3	26.00	25.00	38.00	630	F or W *	SCD 7
118	DM118KD	NH3	26.00	25.00	38.00	730	F or W *	SCD 7
145	DM145KD	NH4	32.00	29.50	41.00	830	F	SCD 7
175	DM175KD	NH4	32.00	29.50	41.00	930	F	SCD 7
220	DM220KD	NH4	32.00	29.50	41.00	1350	F	SCD 9
275	DM275KD	NJ1	39.50	34.00	51.50	1500	F	SCD 9
330	DM330KD	NJ1	39.50	34.00	51.50	1700	F	SCD 9
440	DM440KD	NJ2	48.50	38.40	59.00	2100	F	SCD 10
550	DM550KD	NJ2	48.50	38.40	59.00	2350	F	SCD 10
660	DM660KD	NJ3	51.50	43.40	66.00	2900	F	SCD 10

For shielded units, please add the suffix "S" to the above part numbers. (i.e. DM075KDS)

*WALL MOUNTING KIT AND/OR DRIP PLATE KIT REQUIRED. REFER TO PAGES 271 TO 273 FOR DETAILS.

Products listed on this page are available as 'CE Mark' products. Please consult our sales office.

FOR TERMINATION DETAILS SEE PAGE 131

FOR ACCESSORIES SEE PAGES 271 TO 274



SECTION 4

Selection Tables



Listed below are our standard voltages. Other primary and secondary voltages available are 240, 380 and 600.

ALUMINUM WOUND, THREE PHASE

480 Delta Primary Volts

480Y Secondary Volts

60 Hz

kVA	Catalog Number	Case Style (Pages 260 - 267)	Dimensions			Approx. Weight (Lbs.)	Mtg Type W - Wall F - Floor	Wiring Diagram (Pages 276 - 288)
			Width	Depth	Height			
7.5	DM007KK	NH5	19.40	20.20	21.50	150	F or W *	SCD 8
11	DM011KK	NH5	19.40	20.20	21.50	160	F or W *	SCD 8
14	DM014KK	NH5	19.40	20.20	21.50	170	F or W *	SCD 8
20	DM020KK	NH6	23.90	25.00	28.75	240	F or W *	SCD 7
27	DM027KK	NH6	23.90	25.00	28.75	300	F or W *	SCD 7
34	DM034KK	NH6	23.90	25.00	28.75	330	F or W *	SCD 7
40	DM040KK	NH6	23.90	25.00	28.75	350	F or W *	SCD 7
51	DM051KK	NH6	23.90	25.00	28.75	430	F or W *	SCD 7
63	DM063KK	NH3	26.00	25.00	38.00	530	F or W *	SCD 7
75	DM075KK	NH3	26.00	25.00	38.00	580	F or W *	SCD 7
93	DM093KK	NH3	26.00	25.00	38.00	630	F or W *	SCD 7
118	DM118KK	NH3	26.00	25.00	38.00	730	F or W *	SCD 7
145	DM145KK	NH4	32.00	29.50	41.00	830	F	SCD 7
175	DM175KK	NH4	32.00	29.50	41.00	930	F	SCD 7
220	DM220KK	NH4	32.00	29.50	41.00	1350	F	SCD 9
275	DM275KK	NJ1	39.50	34.00	51.50	1500	F	SCD 9
330	DM330KK	NJ1	39.50	34.00	51.50	1700	F	SCD 9
440	DM440KK	NJ2	48.50	38.40	59.00	2100	F	SCD 10
550	DM550KK	NJ2	48.50	38.40	59.00	2350	F	SCD 10
660	DM660KK	NJ3	51.50	43.40	66.00	2900	F	SCD 10

For shielded units, please add the suffix "S" to the above part numbers. (i.e. DM075KKS)

*WALL MOUNTING KIT AND/OR DRIP PLATE KIT REQUIRED. REFER TO PAGES 271 TO 273 FOR DETAILS.

575 Delta Primary Volts

460Y Secondary Volts

60 Hz

kVA	Catalog Number	Case Style (Pages 260 - 267)	Dimensions			Approx. Weight (Lbs.)	Mtg Type W - Wall F - Floor	Wiring Diagram (Pages 276 - 288)
			Width	Depth	Height			
7.5	DM007NJ	NH5	19.40	20.20	21.50	150	F or W *	SCD 8
11	DM011NJ	NH5	19.40	20.20	21.50	160	F or W *	SCD 8
14	DM014NJ	NH5	19.40	20.20	21.50	170	F or W *	SCD 8
20	DM020NJ	NH6	23.90	25.00	28.75	240	F or W *	SCD 7
27	DM027NJ	NH6	23.90	25.00	28.75	300	F or W *	SCD 7
34	DM034NJ	NH6	23.90	25.00	28.75	330	F or W *	SCD 7
40	DM040NJ	NH6	23.90	25.00	28.75	350	F or W *	SCD 7
51	DM051NJ	NH6	23.90	25.00	28.75	430	F or W *	SCD 7
63	DM063NJ	NH3	26.00	25.00	38.00	530	F or W *	SCD 7
75	DM075NJ	NH3	26.00	25.00	38.00	580	F or W *	SCD 7
93	DM093NJ	NH3	26.00	25.00	38.00	630	F or W *	SCD 7
118	DM118NJ	NH3	26.00	25.00	38.00	730	F or W *	SCD 7
145	DM145NJ	NH4	32.00	29.50	41.00	830	F	SCD 7
175	DM175NJ	NH4	32.00	29.50	41.00	930	F	SCD 7
220	DM220NJ	NH4	32.00	29.50	41.00	1350	F	SCD 9
275	DM275NJ	NJ1	39.50	34.00	51.50	1500	F	SCD 9
330	DM330NJ	NJ1	39.50	34.00	51.50	1700	F	SCD 9
440	DM440NJ	NJ2	48.50	38.40	59.00	2100	F	SCD 10
550	DM550NJ	NJ2	48.50	38.40	59.00	2350	F	SCD 10
660	DM660NJ	NJ3	51.50	43.40	66.00	2900	F	SCD 10

For shielded units, please add the suffix "S" to the above part numbers. (i.e. DM075NJS)

*WALL MOUNTING KIT AND/OR DRIP PLATE KIT REQUIRED. REFER TO PAGES 271 TO 273 FOR DETAILS.

Products listed on this page are available as 'CE Mark' products. Please consult our sales office.

FOR TERMINATION DETAILS SEE PAGE 131

FOR ACCESSORIES SEE PAGES 271 TO 274

Data subject to change without notice.



Selection Tables



Listed below are our standard voltages. Other primary and secondary voltages available are 240, 380 and 600.

ALUMINUM WOUND, THREE PHASE

575 Delta Primary Volts

575Y Secondary Volts

60 Hz

kVA	Catalog Number	Case Style (Pages 260 - 267)	Dimensions			Approx. Weight (Lbs.)	Mtg Type W - Wall F - Floor	Wiring Diagram (Pages 276 - 288)
			Width	Depth	Height			
7.5	DM007NN	NH5	19.40	20.20	21.50	150	F or W *	SCD 8
11	DM011NN	NH5	19.40	20.20	21.50	160	F or W *	SCD 8
14	DM014NN	NH5	19.40	20.20	21.50	170	F or W *	SCD 8
20	DM020NN	NH6	23.90	25.00	28.75	240	F or W *	SCD 7
27	DM027NN	NH6	23.90	25.00	28.75	300	F or W *	SCD 7
34	DM034NN	NH6	23.90	25.00	28.75	330	F or W *	SCD 7
40	DM040NN	NH6	23.90	25.00	28.75	350	F or W *	SCD 7
51	DM051NN	NH6	23.90	25.00	28.75	430	F or W *	SCD 7
63	DM063NN	NH3	26.00	25.00	38.00	530	F or W *	SCD 7
75	DM075NN	NH3	26.00	25.00	38.00	580	F or W *	SCD 7
93	DM093NN	NH3	26.00	25.00	38.00	630	F or W *	SCD 7
118	DM118NN	NH3	26.00	25.00	38.00	730	F or W *	SCD 7
145	DM145NN	NH4	32.00	29.50	41.00	830	F	SCD 7
175	DM175NN	NH4	32.00	29.50	41.00	930	F	SCD 7
220	DM220NN	NH4	32.00	29.50	41.00	1350	F	SCD 9
275	DM275NN	NJ1	39.50	34.00	51.50	1500	F	SCD 9
330	DM330NN	NJ1	39.50	34.00	51.50	1700	F	SCD 9
440	DM440NN	NJ2	48.50	38.40	59.00	2100	F	SCD 10
550	DM550NN	NJ2	48.50	38.40	59.00	2350	F	SCD 10
660	DM660NN	NJ3	51.50	43.40	66.00	2900	F	SCD 10

For shielded units, please add the suffix "S" to the above part numbers. (i.e. DM075NNS)

*WALL MOUNTING KIT AND/OR DRIP PLATE KIT REQUIRED. REFER TO PAGES 271 TO 273 FOR DETAILS.

COPPER WOUND, THREE PHASE

208 Delta Primary Volts

480Y Secondary Volts

60 Hz

kVA	Catalog Number	Case Style (Pages 260 - 267)	Dimensions			Approx. Weight (Lbs.)	Mtg Type W - Wall F - Floor	Wiring Diagram (Pages 276 - 288)
			Width	Depth	Height			
7.5	DM007BKCN	NH5	19.40	20.20	21.50	150	F or W *	SCD 8
11	DM011BKCN	NH5	19.40	20.20	21.50	170	F or W *	SCD 8
14	DM014BKCN	NH5	19.40	20.20	21.50	210	F or W *	SCD 8
20	DM020BKC	NH6	23.90	25.00	28.75	270	F or W *	SCD 7
27	DM027BKC	NH6	23.90	25.00	28.75	330	F or W *	SCD 7
34	DM034BKC	NH6	23.90	25.00	28.75	350	F or W *	SCD 7
40	DM040BKC	NH6	23.90	25.00	28.75	380	F or W *	SCD 7
51	DM051BKC	NH6	23.90	25.00	28.75	450	F or W *	SCD 7
63	DM063BKC	NH3	26.00	25.00	38.00	550	F or W *	SCD 7
75	DM075BKC	NH3	26.00	25.00	38.00	600	F or W *	SCD 7
93	DM093BKC	NH3	26.00	25.00	38.00	630	F or W *	SCD 7
118	DM118BKC	NH3	26.00	25.00	38.00	880	F	SCD 7
145	DM145BKC	NH4	32.00	29.50	41.00	930	F	SCD 7
175	DM175BKC	NH4	32.00	29.50	41.00	1100	F	SCD 7
220	DM220BKC	NH4	32.00	29.50	41.00	1450	F	SCD 9
275	DM275BKC	NJ1	39.50	34.00	51.50	1680	F	SCD 9
330	DM330BKC	NJ1	39.50	34.00	51.50	1850	F	SCD 9
440	DM440BKC	NJ2	48.50	38.40	59.00	2350	F	SCD 10
550	DM550BKC	NJ2	48.50	38.40	59.00	2800	F	SCD 10
660	DM660BKC	NJ3	51.50	43.40	66.00	3250	F	SCD 10

For shielded units, please replace the suffix "C" with a 'K' on the above part numbers. (i.e. DM075BKCK)

*WALL MOUNTING KIT AND/OR DRIP PLATE KIT REQUIRED. REFER TO PAGES 271 TO 273 FOR DETAILS.

Products listed on this page are available as 'CE Mark' products. Please consult our sales office.

FOR TERMINATION DETAILS SEE PAGE 131

FOR ACCESSORIES SEE PAGES 271 TO 274



Selection Tables



Listed below are our standard voltages. Other primary and secondary voltages available are 240, 380 and 600.

COPPER WOUND, THREE PHASE

230 Delta Primary Volts

230Y Secondary Volts

60 Hz

kVA	Catalog Number	Case Style (Pages 260 - 267)	Dimensions			Approx. Weight (Lbs.)	Mtg Type W - Wall F - Floor	Wiring Diagram (Pages 276 - 288)
			Width	Depth	Height			
7.5	DM007CCCN	NH5	19.40	20.20	21.50	150	F or W *	SCD 8
11	DM011CCCN	NH5	19.40	20.20	21.50	170	F or W *	SCD 8
14	DM014CCCN	NH5	19.40	20.20	21.50	210	F or W *	SCD 8
20	DM020CCC	NH6	23.90	25.00	28.75	270	F or W *	SCD 7
27	DM027CCC	NH6	23.90	25.00	28.75	330	F or W *	SCD 7
34	DM034CCC	NH6	23.90	25.00	28.75	350	F or W *	SCD 7
40	DM040CCC	NH6	23.90	25.00	28.75	380	F or W *	SCD 7
51	DM051CCC	NH6	23.90	25.00	28.75	450	F or W *	SCD 7
63	DM063CCC	NH3	26.00	25.00	38.00	550	F or W *	SCD 7
75	DM075CCC	NH3	26.00	25.00	38.00	600	F or W *	SCD 7
93	DM093CCC	NH3	26.00	25.00	38.00	630	F or W *	SCD 7
118	DM118CCC	NH3	26.00	25.00	38.00	880	F	SCD 7
145	DM145CCC	NH4	32.00	29.50	41.00	930	F	SCD 7
175	DM175CCC	NH4	32.00	29.50	41.00	1100	F	SCD 7
220	DM220CCC	NH4	32.00	29.50	41.00	1450	F	SCD 9
275	DM275CCC	NJ1	39.50	34.00	51.50	1680	F	SCD 9
330	DM330CCC	NJ1	39.50	34.00	51.50	1850	F	SCD 9
440	DM440CCC	NJ2	48.50	38.40	59.00	2350	F	SCD 10
550	DM550CCC	NJ2	48.50	38.40	59.00	2800	F	SCD 10
660	DM660CCC	NJ3	51.50	43.40	66.00	3250	F	SCD 10

For shielded units, please replace the suffix "C" with a 'K' on the above part numbers. (i.e. DM075CCK)

*WALL MOUNTING KIT AND/OR DRIP PLATE KIT REQUIRED. REFER TO PAGES 271 TO 273 FOR DETAILS.

460 Delta Primary Volts

230Y Secondary Volts

60 Hz

kVA	Catalog Number	Case Style (Pages 260 - 267)	Dimensions			Approx. Weight (Lbs.)	Mtg Type W - Wall F - Floor	Wiring Diagram (Pages 276 - 288)
			Width	Depth	Height			
7.5	DM007JCCN	NH5	19.40	20.20	21.50	150	F or W *	SCD 8
11	DM011JCCN	NH5	19.40	20.20	21.50	170	F or W *	SCD 8
14	DM014JCCN	NH5	19.40	20.20	21.50	210	F or W *	SCD 8
20	DM020JCCN	NH6	23.90	25.00	28.75	270	F or W *	SCD 7
27	DM027JCCN	NH6	23.90	25.00	28.75	330	F or W *	SCD 7
34	DM034JCC	NH6	23.90	25.00	28.75	350	F or W *	SCD 7
40	DM040JCC	NH6	23.90	25.00	28.75	380	F or W *	SCD 7
51	DM051JCC	NH6	23.90	25.00	28.75	450	F or W *	SCD 7
63	DM063JCC	NH3	26.00	25.00	38.00	550	F or W *	SCD 7
75	DM075JCC	NH3	26.00	25.00	38.00	600	F or W *	SCD 7
93	DM093JCC	NH3	26.00	25.00	38.00	630	F or W *	SCD 7
118	DM118JCC	NH3	26.00	25.00	38.00	880	F	SCD 7
145	DM145JCC	NH4	32.00	29.50	41.00	930	F	SCD 7
175	DM175JCC	NH4	32.00	29.50	41.00	1100	F	SCD 7
220	DM220JCC	NH4	32.00	29.50	41.00	1450	F	SCD 9
275	DM275JCC	NJ1	39.50	34.00	51.50	1680	F	SCD 9
330	DM330JCC	NJ1	39.50	34.00	51.50	1850	F	SCD 9
440	DM440JCC	NJ2	48.50	38.40	59.00	2350	F	SCD 10
550	DM550JCC	NJ2	48.50	38.40	59.00	2800	F	SCD 10
660	DM660JCC	NJ3	51.50	43.40	66.00	3250	F	SCD 10

For shielded units, please replace the suffix "C" with a 'K' on the above part numbers. (i.e. DM075JCK)

*WALL MOUNTING KIT AND/OR DRIP PLATE KIT REQUIRED. REFER TO PAGES 271 TO 273 FOR DETAILS.

Products listed on this page are available as 'CE Mark' products. Please consult our sales office.

FOR TERMINATION DETAILS SEE PAGE 131

FOR ACCESSORIES SEE PAGES 271 TO 274

Data subject to change without notice.



Selection Tables



Listed below are our standard voltages. Other primary and secondary voltages available are 240, 380 and 600.

COPPER WOUND, THREE PHASE

460 Delta Primary Volts

400Y Secondary Volts

60 Hz

kVA	Catalog Number	Case Style (Pages 260 - 267)	Dimensions			Approx. Weight (Lbs.)	Mtg Type W - Wall F - Floor	Wiring Diagram (Pages 276 - 288)
			Width	Depth	Height			
7.5	DM007JHCN	NH5	19.40	20.20	21.50	150	F or W *	SCD 8
11	DM011JHCN	NH5	19.40	20.20	21.50	170	F or W *	SCD 8
14	DM014JHCN	NH5	19.40	20.20	21.50	210	F or W *	SCD 8
20	DM020JHCN	NH6	23.90	25.00	28.75	270	F or W *	SCD 7
27	DM027JHCN	NH6	23.90	25.00	28.75	330	F or W *	SCD 7
34	DM034JHC	NH6	23.90	25.00	28.75	350	F or W *	SCD 7
40	DM040JHC	NH6	23.90	25.00	28.75	380	F or W *	SCD 7
51	DM051JHC	NH6	23.90	25.00	28.75	450	F or W *	SCD 7
63	DM063JHC	NH3	26.00	25.00	38.00	550	F or W *	SCD 7
75	DM075JHC	NH3	26.00	25.00	38.00	600	F or W *	SCD 7
93	DM093JHC	NH3	26.00	25.00	38.00	630	F or W *	SCD 7
118	DM118JHC	NH3	26.00	25.00	38.00	880	F	SCD 7
145	DM145JHC	NH4	32.00	29.50	41.00	930	F	SCD 7
175	DM175JHC	NH4	32.00	29.50	41.00	1100	F	SCD 7
220	DM220JHC	NH4	32.00	29.50	41.00	1450	F	SCD 9
275	DM275JHC	NJ1	39.50	34.00	51.50	1680	F	SCD 9
330	DM330JHC	NJ1	39.50	34.00	51.50	1850	F	SCD 9
440	DM440JHC	NJ2	48.50	38.40	59.00	2350	F	SCD 10
550	DM550JHC	NJ2	48.50	38.40	59.00	2800	F	SCD 10
660	DM660JHC	NJ3	51.50	43.40	66.00	3250	F	SCD 10

For shielded units, please replace the suffix "C" with a 'K' on the above part numbers. (i.e. DM075JHK)

*WALL MOUNTING KIT AND/OR DRIP PLATE KIT REQUIRED. REFER TO PAGES 271 TO 273 FOR DETAILS.

460 Delta Primary Volts

460Y Secondary Volts

60 Hz

kVA	Catalog Number	Case Style (Pages 260 - 267)	Dimensions			Approx. Weight (Lbs.)	Mtg Type W - Wall F - Floor	Wiring Diagram (Pages 276-288)
			Width	Depth	Height			
7.5	DM007JJCN	NH5	19.40	20.20	21.50	150	F or W *	SCD 8
11	DM011JJCN	NH5	19.40	20.20	21.50	170	F or W *	SCD 8
14	DM014JJCN	NH5	19.40	20.20	21.50	210	F or W *	SCD 8
20	DM020JJCN	NH6	23.90	25.00	28.75	270	F or W *	SCD 7
27	DM027JJCN	NH6	23.90	25.00	28.75	330	F or W *	SCD 7
34	DM034JJC	NH6	23.90	25.00	28.75	350	F or W *	SCD 7
40	DM040JJC	NH6	23.90	25.00	28.75	380	F or W *	SCD 7
51	DM051JJC	NH6	23.90	25.00	28.75	450	F or W *	SCD 7
63	DM063JJC	NH3	26.00	25.00	38.00	550	F or W *	SCD 7
75	DM075JJC	NH3	26.00	25.00	38.00	600	F or W *	SCD 7
93	DM093JJC	NH3	26.00	25.00	38.00	630	F or W *	SCD 7
118	DM118JJC	NH3	26.00	25.00	38.00	880	F	SCD 7
145	DM145JJC	NH4	32.00	29.50	41.00	930	F	SCD 7
175	DM175JJC	NH4	32.00	29.50	41.00	1100	F	SCD 7
220	DM220JJC	NH4	32.00	29.50	41.00	1450	F	SCD 9
275	DM275JJC	NJ1	39.50	34.00	51.50	1680	F	SCD 9
330	DM330JJC	NJ1	39.50	34.00	51.50	1850	F	SCD 9
440	DM440JJC	NJ2	48.50	38.40	59.00	2350	F	SCD 10
550	DM550JJC	NJ2	48.50	38.40	59.00	2800	F	SCD 10
660	DM660JJC	NJ3	51.50	43.40	66.00	3250	F	SCD 10

For shielded units, please replace the suffix "C" with a 'K' on the above part numbers. (i.e. DM075JJK)

*WALL MOUNTING KIT AND/OR DRIP PLATE KIT REQUIRED. REFER TO PAGES 271 TO 273 FOR DETAILS.

Products listed on this page are available as 'CE Mark' products. Please consult our sales office.

FOR TERMINATION DETAILS SEE PAGE 131

FOR ACCESSORIES SEE PAGES 271 TO 274



SECTION 4

Selection Tables



Listed below are our standard voltages. Other primary and secondary voltages available are 240, 380 and 600.

COPPER WOUND, THREE PHASE

480 Delta Primary Volts

240Y Secondary Volts

60 Hz

kVA	Catalog Number	Case Style (Pages 260 - 267)	Dimensions			Approx. Weight (Lbs.)	Mtg Type W - Wall F - Floor	Wiring Diagram (Pages 276 - 288)
			Width	Depth	Height			
7.5	DM007KDCN	NH5	19.40	20.20	21.50	150	F or W *	SCD 8
11	DM011KDCN	NH5	19.40	20.20	21.50	170	F or W *	SCD 8
14	DM014KDCN	NH5	19.40	20.20	21.50	210	F or W *	SCD 8
20	DM020KDCN	NH6	23.90	25.00	28.75	270	F or W *	SCD 7
27	DM027KDCN	NH6	23.90	25.00	28.75	330	F or W *	SCD 7
34	DM034KDCN	NH6	23.90	25.00	28.75	350	F or W *	SCD 7
40	DM040KDC	NH6	23.90	25.00	28.75	380	F or W *	SCD 7
51	DM051KDC	NH6	23.90	25.00	28.75	450	F or W *	SCD 7
63	DM063KDC	NH3	26.00	25.00	38.00	550	F or W *	SCD 7
75	DM075KDC	NH3	26.00	25.00	38.00	600	F or W *	SCD 7
93	DM093KDC	NH3	26.00	25.00	38.00	630	F or W *	SCD 7
118	DM118KDC	NH3	26.00	25.00	38.00	880	F	SCD 7
145	DM145KDC	NH4	32.00	29.50	41.00	930	F	SCD 7
175	DM175KDC	NH4	32.00	29.50	41.00	1100	F	SCD 7
220	DM220KDC	NH4	32.00	29.50	41.00	1450	F	SCD 9
275	DM275KDC	NJ1	39.50	34.00	51.50	1680	F	SCD 9
330	DM330KDC	NJ1	39.50	34.00	51.50	1850	F	SCD 9
440	DM440KDC	NJ2	48.50	38.40	59.00	2350	F	SCD 10
550	DM550KDC	NJ2	48.50	38.40	59.00	2800	F	SCD 10
660	DM660KDC	NJ3	51.50	43.40	66.00	3250	F	SCD 10

For shielded units, please replace the suffix "C" with a 'K' on the above part numbers. (i.e. DM075KDK)

*WALL MOUNTING KIT AND/OR DRIP PLATE KIT REQUIRED. REFER TO PAGES 271 TO 273 FOR DETAILS.

480 Delta Primary Volts

480Y Secondary Volts

60 Hz

kVA	Catalog Number	Case Style (Pages 260 - 267)	Dimensions			Approx. Weight (Lbs.)	Mtg Type W - Wall F - Floor	Wiring Diagram (Pages 276 - 288)
			Width	Depth	Height			
7.5	DM007KKCN	NH5	19.40	20.20	21.50	150	F or W *	SCD 8
11	DM011KKCN	NH5	19.40	20.20	21.50	170	F or W *	SCD 8
14	DM014KKCN	NH5	19.40	20.20	21.50	210	F or W *	SCD 8
20	DM020KKCN	NH6	23.90	25.00	28.75	270	F or W *	SCD 7
27	DM027KKCN	NH6	23.90	25.00	28.75	330	F or W *	SCD 7
34	DM034KKCN	NH6	23.90	25.00	28.75	350	F or W *	SCD 7
40	DM040KKC	NH6	23.90	25.00	28.75	380	F or W *	SCD 7
51	DM051KKC	NH6	23.90	25.00	28.75	450	F or W *	SCD 7
63	DM063KKC	NH3	26.00	25.00	38.00	550	F or W *	SCD 7
75	DM075KKC	NH3	26.00	25.00	38.00	600	F or W *	SCD 7
93	DM093KKC	NH3	26.00	25.00	38.00	630	F or W *	SCD 7
118	DM118KKC	NH3	26.00	25.00	38.00	880	F	SCD 7
145	DM145KKC	NH4	32.00	29.50	41.00	930	F	SCD 7
175	DM175KKC	NH4	32.00	29.50	41.00	1100	F	SCD 7
220	DM220KKC	NH4	32.00	29.50	41.00	1450	F	SCD 9
275	DM275KKC	NJ1	39.50	34.00	51.50	1680	F	SCD 9
330	DM330KKC	NJ1	39.50	34.00	51.50	1850	F	SCD 9
440	DM440KKC	NJ2	48.50	38.40	59.00	2350	F	SCD 10
550	DM550KKC	NJ2	48.50	38.40	59.00	2800	F	SCD 10
660	DM660KKC	NJ3	51.50	43.40	66.00	3250	F	SCD 10

For shielded units, please replace the suffix "C" with a 'K' on the above part numbers. (i.e. DM075KKK)

*WALL MOUNTING KIT AND/OR DRIP PLATE KIT REQUIRED. REFER TO PAGES 271 TO 273 FOR DETAILS.

SECTION 4



Selection Tables



Listed below are our standard voltages. Other primary and secondary voltages available are 240, 380 and 600.

COPPER WOUND, THREE PHASE

575 Delta Primary Volts

460Y Secondary Volts

60 Hz

kVA	Catalog Number	Case Style (Pages 260 - 267)	Dimensions			Approx. Weight (Lbs.)	Mtg Type W - Wall F - Floor	Wiring Diagram (Pages 276 - 288)
			Width	Depth	Height			
7.5	DM007NJC	NH5	19.40	20.20	21.50	150	F or W *	SCD 8
11	DM011NJC	NH5	19.40	20.20	21.50	170	F or W *	SCD 8
14	DM014NJC	NH5	19.40	20.20	21.50	210	F or W *	SCD 8
20	DM020NJC	NH6	23.90	25.00	28.75	270	F or W *	SCD 7
27	DM027NJC	NH6	23.90	25.00	28.75	330	F or W *	SCD 7
34	DM034NJC	NH6	23.90	25.00	28.75	350	F or W *	SCD 7
40	DM040NJC	NH6	23.90	25.00	28.75	380	F or W *	SCD 7
51	DM051NJC	NH6	23.90	25.00	28.75	450	F or W *	SCD 7
63	DM063NJC	NH3	26.00	25.00	38.00	550	F or W *	SCD 7
75	DM075NJC	NH3	26.00	25.00	38.00	600	F or W *	SCD 7
93	DM093NJC	NH3	26.00	25.00	38.00	630	F or W *	SCD 7
118	DM118NJC	NH3	26.00	25.00	38.00	880	F	SCD 7
145	DM145NJC	NH4	32.00	29.50	41.00	930	F	SCD 7
175	DM175NJC	NH4	32.00	29.50	41.00	1100	F	SCD 7
220	DM220NJC	NH4	32.00	29.50	41.00	1450	F	SCD 9
275	DM275NJC	NJ1	39.50	34.00	51.50	1680	F	SCD 9
330	DM330NJC	NJ1	39.50	34.00	51.50	1850	F	SCD 9
440	DM440NJC	NJ2	48.50	38.40	59.00	2350	F	SCD 10
550	DM550NJC	NJ2	48.50	38.40	59.00	2800	F	SCD 10
660	DM660NJC	NJ3	51.50	43.40	66.00	3250	F	SCD 10

For shielded units, please replace the suffix "C" with a 'K' on the above part numbers. (i.e. DM075NJK)

*WALL MOUNTING KIT AND/OR DRIP PLATE KIT REQUIRED. REFER TO PAGES 271 TO 273 FOR DETAILS.

575 Delta Primary Volts

575Y Secondary Volts

60 Hz

kVA	Catalog Number	Case Style (Pages 260 - 267)	Dimensions			Approx. Weight (Lbs.)	Mtg Type W - Wall F - Floor	Wiring Diagram (Pages 276 - 288)
			Width	Depth	Height			
7.5	DM007NNC	NH5	19.40	20.20	21.50	150	F or W *	SCD 8
11	DM011NNC	NH5	19.40	20.20	21.50	170	F or W *	SCD 8
14	DM014NNC	NH5	19.40	20.20	21.50	210	F or W *	SCD 8
20	DM020NNC	NH6	23.90	25.00	28.75	270	F or W *	SCD 7
27	DM027NNC	NH6	23.90	25.00	28.75	330	F or W *	SCD 7
34	DM034NNC	NH6	23.90	25.00	28.75	350	F or W *	SCD 7
40	DM040NNC	NH6	23.90	25.00	28.75	380	F or W *	SCD 7
51	DM051NNC	NH6	23.90	25.00	28.75	450	F or W *	SCD 7
63	DM063NNC	NH3	26.00	25.00	38.00	550	F or W *	SCD 7
75	DM075NNC	NH3	26.00	25.00	38.00	600	F or W *	SCD 7
93	DM093NNC	NH3	26.00	25.00	38.00	630	F or W *	SCD 7
118	DM118NNC	NH3	26.00	25.00	38.00	880	F	SCD 7
145	DM145NNC	NH4	32.00	29.50	41.00	930	F	SCD 7
175	DM175NNC	NH4	32.00	29.50	41.00	1100	F	SCD 7
220	DM220NNC	NH4	32.00	29.50	41.00	1450	F	SCD 9
275	DM275NNC	NJ1	39.50	34.00	51.50	1680	F	SCD 9
330	DM330NNC	NJ1	39.50	34.00	51.50	1850	F	SCD 9
440	DM440NNC	NJ2	48.50	38.40	59.00	2350	F	SCD 10
550	DM550NNC	NJ2	48.50	38.40	59.00	2800	F	SCD 10
660	DM660NNC	NJ3	51.50	43.40	66.00	3250	F	SCD 10

For shielded units, please replace the suffix "C" with a 'K' on the above part numbers. (i.e. DM075NNK)

*WALL MOUNTING KIT AND/OR DRIP PLATE KIT REQUIRED. REFER TO PAGES 271 TO 273 FOR DETAILS.

Products listed on this page are available as 'CE Mark' products. Please consult our sales office.

FOR TERMINATION DETAILS SEE PAGE 131

FOR ACCESSORIES SEE PAGES 271 TO 274



SECTION 4

TERMINATION DETAILS



THREE PHASE, ALUMINUM AND COPPER TERMINATION - LUGS OR PADS

kVA	VOLTAGE							
	208	230	240	380	460	480	575	600
7.5	Lugs	Lugs	Lugs	Lugs	Lugs	Lugs	Lugs	Lugs
11	Lugs	Lugs	Lugs	Lugs	Lugs	Lugs	Lugs	Lugs
14	Lugs	Lugs	Lugs	Lugs	Lugs	Lugs	Lugs	Lugs
20	Lugs	Lugs	Lugs	Lugs	Lugs	Lugs	Lugs	Lugs
27	Lugs	Lugs	Lugs	Lugs	Lugs	Lugs	Lugs	Lugs
34	Lugs	Lugs	Lugs	Lugs	Lugs	Lugs	Lugs	Lugs
40	Lugs	Lugs	Lugs	Lugs	Lugs	Lugs	Lugs	Lugs
51	Lugs	Lugs	Lugs	Lugs	Lugs	Lugs	Lugs	Lugs
63	Lugs	Lugs	Lugs	Lugs	Lugs	Lugs	Lugs	Lugs
75	Lugs	Lugs	Lugs	Lugs	Lugs	Lugs	Lugs	Lugs
93	Lugs	Lugs	Lugs	Lugs	Lugs	Lugs	Lugs	Lugs
118	Diagram 1A	Diagram 1A	Diagram 1A	Lugs	Lugs	Lugs	Lugs	Lugs
145	Diagram 1A	Diagram 1A	Diagram 1A	Lugs	Lugs	Lugs	Lugs	Lugs
175	Diagram 1A	Diagram 1A	Diagram 1A	Lugs	Lugs	Lugs	Lugs	Lugs
220	Diagram 2	Diagram 1A	Diagram 1A	Diagram 1A	Diagram 1A	Lugs	Lugs	Lugs
275	Diagram 2	Diagram 2	Diagram 2	Diagram 1A	Diagram 1A	Diagram 1A	Diagram 1A	Lugs
330	Diagram 2	Diagram 2	Diagram 2	Diagram 1A	Diagram 1A	Diagram 1A	Diagram 1A	Diagram 1A
440	Diagram 3	Diagram 3	Diagram 3	Diagram 2	Diagram 1A	Diagram 1A	Diagram 1A	Diagram 1A
550	Diagram 3	Diagram 3	Diagram 3	Diagram 2	Diagram 2	Diagram 2	Diagram 1A	Diagram 1A
660	Diagram 3	Diagram 3	Diagram 3	Diagram 3	Diagram 2	Diagram 2	Diagram 2	Diagram 2

SECTION 4

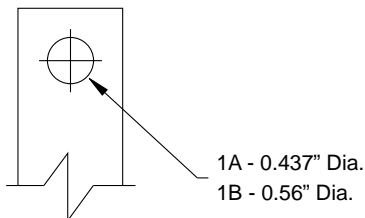

DIAGRAM 1

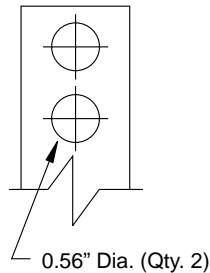

DIAGRAM 2

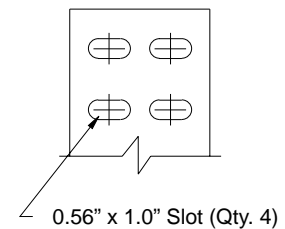

DIAGRAM 3

HPS TRIBUNE

Energy Efficient (TP1/C802.2) Drive Isolation Transformers

ALUMINUM AND COPPER WOUND FEATURES

THREE PHASE SPECIFICATIONS



	7.5 to 175 kVA	220 to 660 kVA
Efficiency	Meets TP1/C802.2 efficiencies at 35% of rated load. Efficiencies are calculated under a linear load profile. Note: Energy efficient drive isolation transformers are not required by law in the U.S. Please refer to the standard drive isolation transformers on pages 121-130.	
UL Listed	File: E112313	File: E112313
CSA Certified	File: LR3902	File: LR3902
Frequency	60 Hz	60 Hz
Insulation System	220°C (150°C rise) 200°C (130°C rise) on some Copper units up to 40kVA	220°C (150°C rise) (Optional 115°C and 80°C rise available)
Enclosure Type	Heavy Duty Ventilated NEMA Type 3R Optional NEMA 4, 4X(stainless steel) and 12	Heavy Duty Ventilated NEMA Type 3R Optional NEMA 4, 4X(stainless steel) and 12
Enclosure Finish	ANSI 61 Grey, UL50	ANSI 61 Grey, UL50
Neutral	Neutral terminal for field connection (on applicable units).	Neutral terminal for field connection (on applicable units).
Standard Primary Taps	Refer to wiring diagrams for details.	Refer to wiring diagrams for details.
Termination	Front accessible separate high and low voltage terminations, suitable for copper and aluminum are provided for easy cable installation.	Front accessible separate high and low voltage terminations, suitable for copper and aluminum are provided for easy cable installation.
Thermostat	Standard on all units.	Standard on all units.
Conduit Knock-Outs	Standard on all units.	None
Impedance	Typically 3 to 6%	Typically 3 to 6%
Mounting	Floor mounting available on all units. Wall & ceiling mount available on units up to 750 lbs. Refer to selection tables for details.	Floor mounting only.
Seismic	Meets Occupancy Category III $I_p=1.25$ for $S_s=1.0g$ per IBC 2006; section 1613, earthquake loads and NBCC 2005 for ground level installations only for all locations in North America.	Meets Occupancy Category III $I_p=1.25$ for $S_s=1.0g$ per IBC 2006; section 1613, earthquake loads and NBCC 2005 for ground level installations only for all locations in North America.
Short Circuit Withstand	Meets UL and CSA short circuit withstand requirements.	Meets UL and CSA short circuit withstand requirements.

SECTION 4



Selection Tables



Listed below are our standard voltages. Other primary and secondary voltages available are 240, 380 and 600.

ALUMINUM WOUND, THREE PHASE

208 Delta Primary Volts

480Y Secondary Volts

60 Hz

kVA	Catalog Number	Case Style (Pages 260 - 267)	Dimensions			Approx. Weight (Lbs.)	Mtg Type W - Wall F - Floor	Wiring Diagram (Pages 276 - 288)
			Width	Depth	Height			
7.5	Outside of C802.2/TP1 guidelines, refer to Non-Energy Efficient Drive Isolation Transformers on page 122							
11	Outside of C802.2/TP1 guidelines, refer to Non-Energy Efficient Drive Isolation Transformers on page 122							
14	Outside of C802.2/TP1 guidelines, refer to Non-Energy Efficient Drive Isolation Transformers on page 122							
20	DE020BK	NH6	23.90	25.00	28.75	240	F or W *	SCD 7
27	DE027BK	NH6	23.90	25.00	28.75	300	F or W *	SCD 7
34	DE034BK	NH6	23.90	25.00	28.75	330	F or W *	SCD 7
40	DE040BK	NH6	23.90	25.00	28.75	350	F or W *	SCD 7
51	DE051BK	NH6	23.90	25.00	28.75	430	F or W *	SCD 7
63	DE063BK	NH3	26.00	25.00	38.00	530	F or W *	SCD 7
75	DE075BK	NH3	26.00	25.00	38.00	580	F or W *	SCD 7
93	DE093BK	NH3	26.00	25.00	38.00	630	F or W *	SCD 7
118	DE118BK	NH3	26.00	25.00	38.00	730	F or W *	SCD 7
145	DE145BK	NH4	32.00	29.50	41.00	830	F	SCD 7
175	DE175BK	NH4	32.00	29.50	41.00	930	F	SCD 7
220	DE220BK	NH4	32.00	29.50	41.00	1350	F	SCD 9
275	DE275BK	NJ1	39.50	34.00	51.50	1500	F	SCD 9
330	DE330BK	NJ1	39.50	34.00	51.50	1700	F	SCD 9
440	DE440BK	NJ2	48.50	38.40	59.00	2100	F	SCD 10
550	DE550BK	NJ2	48.50	38.40	59.00	2350	F	SCD 10
660	DE660BK	NJ3	51.50	43.40	66.00	2900	F	SCD 10

For shielded units, please add the suffix "S" to the above part numbers. (i.e. DE075BKS)

*WALL MOUNTING KIT AND/OR DRIP PLATE KIT REQUIRED. REFER TO PAGES 271 TO 273 FOR DETAILS.

230 Delta Primary Volts

230Y Secondary Volts

60 Hz

kVA	Catalog Number	Case Style (Pages 260 - 267)	Dimensions			Approx. Weight (Lbs.)	Mtg Type W - Wall F - Floor	Wiring Diagram (Pages 276 - 288)
			Width	Depth	Height			
7.5	Outside of C802.2/TP1 guidelines, refer to Non-Energy Efficient Drive Isolation Transformers on page 122							
11	Outside of C802.2/TP1 guidelines, refer to Non-Energy Efficient Drive Isolation Transformers on page 122							
14	Outside of C802.2/TP1 guidelines, refer to Non-Energy Efficient Drive Isolation Transformers on page 122							
20	DE020CC	NH6	23.90	25.00	28.75	240	F or W *	SCD 7
27	DE027CC	NH6	23.90	25.00	28.75	300	F or W *	SCD 7
34	DE034CC	NH6	23.90	25.00	28.75	330	F or W *	SCD 7
40	DE040CC	NH6	23.90	25.00	28.75	350	F or W *	SCD 7
51	DE051CC	NH6	23.90	25.00	28.75	430	F or W *	SCD 7
63	DE063CC	NH3	26.00	25.00	38.00	530	F or W *	SCD 7
75	DE075CC	NH3	26.00	25.00	38.00	580	F or W *	SCD 7
93	DE093CC	NH3	26.00	25.00	38.00	630	F or W *	SCD 7
118	DE118CC	NH3	26.00	25.00	38.00	730	F or W *	SCD 7
145	DE145CC	NH4	32.00	29.50	41.00	830	F	SCD 7
175	DE175CC	NH4	32.00	29.50	41.00	930	F	SCD 7
220	DE220CC	NH4	32.00	29.50	41.00	1350	F	SCD 9
275	DE275CC	NJ1	39.50	34.00	51.50	1500	F	SCD 9
330	DE330CC	NJ1	39.50	34.00	51.50	1700	F	SCD 9
440	DE440CC	NJ2	48.50	38.40	59.00	2100	F	SCD 10
550	DE550CC	NJ2	48.50	38.40	59.00	2350	F	SCD 10
660	DE660CC	NJ3	51.50	43.40	66.00	2900	F	SCD 10

For shielded units, please add the suffix "S" to the above part numbers. (i.e. DE075CCS)

*WALL MOUNTING KIT AND/OR DRIP PLATE KIT REQUIRED. REFER TO PAGES 271 TO 273 FOR DETAILS.

Products listed on this page are available as 'CE Mark' products. Please consult our sales office.

FOR TERMINATION DETAILS SEE PAGE 142

FOR ACCESSORIES SEE PAGES 271 TO 274



Selection Tables



Listed below are our standard voltages. Other primary and secondary voltages available are 240, 380 and 600.

ALUMINUM WOUND, THREE PHASE

460 Delta Primary Volts

230Y Secondary Volts

60 Hz

kVA	Catalog Number	Case Style (Pages 260 - 267)	Dimensions			Approx. Weight (Lbs.)	Mtg Type W - Wall F - Floor	Wiring Diagram (Pages 276 - 288)
			Width	Depth	Height			
7.5	Outside of C802.2/TP1 guidelines, refer to Non-Energy Efficient Drive Isolation Transformers on page 123							
11	Outside of C802.2/TP1 guidelines, refer to Non-Energy Efficient Drive Isolation Transformers on page 123							
14	Outside of C802.2/TP1 guidelines, refer to Non-Energy Efficient Drive Isolation Transformers on page 123							
20	DE020JC	NH6	23.90	25.00	28.75	240	F or W *	SCD 7
27	DE027JC	NH6	23.90	25.00	28.75	300	F or W *	SCD 7
34	DE034JC	NH6	23.90	25.00	28.75	330	F or W *	SCD 7
40	DE040JC	NH6	23.90	25.00	28.75	350	F or W *	SCD 7
51	DE051JC	NH6	23.90	25.00	28.75	430	F or W *	SCD 7
63	DE063JC	NH3	26.00	25.00	38.00	530	F or W *	SCD 7
75	DE075JC	NH3	26.00	25.00	38.00	580	F or W *	SCD 7
93	DE093JC	NH3	26.00	25.00	38.00	630	F or W *	SCD 7
118	DE118JC	NH3	26.00	25.00	38.00	730	F or W *	SCD 7
145	DE145JC	NH4	32.00	29.50	41.00	830	F	SCD 7
175	DE175JC	NH4	32.00	29.50	41.00	930	F	SCD 7
220	DE220JC	NH4	32.00	29.50	41.00	1350	F	SCD 9
275	DE275JC	NJ1	39.50	34.00	51.50	1500	F	SCD 9
330	DE330JC	NJ1	39.50	34.00	51.50	1700	F	SCD 9
440	DE440JC	NJ2	48.50	38.40	59.00	2100	F	SCD 10
550	DE550JC	NJ2	48.50	38.40	59.00	2350	F	SCD 10
660	DE660JC	NJ3	51.50	43.40	66.00	2900	F	SCD 10

For shielded units, please add the suffix "S" to the above part numbers. (i.e. DE075JCS)

*WALL MOUNTING KIT AND/OR DRIP PLATE KIT REQUIRED. REFER TO PAGES 271 TO 273 FOR DETAILS.

460 Delta Primary Volts

400Y Secondary Volts

60 Hz

kVA	Catalog Number	Case Style (Pages 260 - 267)	Dimensions			Approx. Weight (Lbs.)	Mtg Type W - Wall F - Floor	Wiring Diagram (Pages 276 - 288)
			Width	Depth	Height			
7.5	Outside of C802.2/TP1 guidelines, refer to Non-Energy Efficient Drive Isolation Transformers on page 123							
11	Outside of C802.2/TP1 guidelines, refer to Non-Energy Efficient Drive Isolation Transformers on page 123							
14	Outside of C802.2/TP1 guidelines, refer to Non-Energy Efficient Drive Isolation Transformers on page 123							
20	DE020JH	NH6	23.90	25.00	28.75	240	F or W *	SCD 7
27	DE027JH	NH6	23.90	25.00	28.75	300	F or W *	SCD 7
34	DE034JH	NH6	23.90	25.00	28.75	330	F or W *	SCD 7
40	DE040JH	NH6	23.90	25.00	28.75	350	F or W *	SCD 7
51	DE051JH	NH6	23.90	25.00	28.75	430	F or W *	SCD 7
63	DE063JH	NH3	26.00	25.00	38.00	530	F or W *	SCD 7
75	DE075JH	NH3	26.00	25.00	38.00	580	F or W *	SCD 7
93	DE093JH	NH3	26.00	25.00	38.00	630	F or W *	SCD 7
118	DE118JH	NH3	26.00	25.00	38.00	730	F or W *	SCD 7
145	DE145JH	NH4	32.00	29.50	41.00	830	F	SCD 7
175	DE175JH	NH4	32.00	29.50	41.00	930	F	SCD 7
220	DE220JH	NH4	32.00	29.50	41.00	1350	F	SCD 9
275	DE275JH	NJ1	39.50	34.00	51.50	1500	F	SCD 9
330	DE330JH	NJ1	39.50	34.00	51.50	1700	F	SCD 9
440	DE440JH	NJ2	48.50	38.40	59.00	2100	F	SCD 10
550	DE550JH	NJ2	48.50	38.40	59.00	2350	F	SCD 10
660	DE660JH	NJ3	51.50	43.40	66.00	2900	F	SCD 10

For shielded units, please add the suffix "S" to the above part numbers. (i.e. DE075JHS)

*WALL MOUNTING KIT AND/OR DRIP PLATE KIT REQUIRED. REFER TO PAGES 271 TO 273 FOR DETAILS.

Products listed on this page are available as 'CE Mark' products. Please consult our sales office.

FOR TERMINATION DETAILS SEE PAGE 142

FOR ACCESSORIES SEE PAGES 271 TO 274



SECTION 4

Selection Tables



Listed below are our standard voltages. Other primary and secondary voltages available are 240, 380 and 600.

ALUMINUM WOUND, THREE PHASE

460 Delta Primary Volts

460Y Secondary Volts

60 Hz

kVA	Catalog Number	Case Style (Pages 260 - 267)	Dimensions			Approx. Weight (Lbs.)	Mtg Type W - Wall F - Floor	Wiring Diagram (Pages 276 - 288)
			Width	Depth	Height			
7.5	Outside of C802.2/TP1 guidelines, refer to Non-Energy Efficient Drive Isolation Transformers on page 124							
11	Outside of C802.2/TP1 guidelines, refer to Non-Energy Efficient Drive Isolation Transformers on page 124							
14	Outside of C802.2/TP1 guidelines, refer to Non-Energy Efficient Drive Isolation Transformers on page 124							
20	DE020JJ	NH6	23.90	25.00	28.75	240	F or W *	SCD 7
27	DE027JJ	NH6	23.90	25.00	28.75	300	F or W *	SCD 7
34	DE034JJ	NH6	23.90	25.00	28.75	330	F or W *	SCD 7
40	DE040JJ	NH6	23.90	25.00	28.75	350	F or W *	SCD 7
51	DE051JJ	NH6	23.90	25.00	28.75	430	F or W *	SCD 7
63	DE063JJ	NH3	26.00	25.00	38.00	530	F or W *	SCD 7
75	DE075JJ	NH3	26.00	25.00	38.00	580	F or W *	SCD 7
93	DE093JJ	NH3	26.00	25.00	38.00	630	F or W *	SCD 7
118	DE118JJ	NH3	26.00	25.00	38.00	730	F or W *	SCD 7
145	DE145JJ	NH4	32.00	29.50	41.00	830	F	SCD 7
175	DE175JJ	NH4	32.00	29.50	41.00	930	F	SCD 7
220	DE220JJ	NH4	32.00	29.50	41.00	1350	F	SCD 9
275	DE275JJ	NJ1	39.50	34.00	51.50	1500	F	SCD 9
330	DE330JJ	NJ1	39.50	34.00	51.50	1700	F	SCD 9
440	DE440JJ	NJ2	48.50	38.40	59.00	2100	F	SCD 10
550	DE550JJ	NJ2	48.50	38.40	59.00	2350	F	SCD 10
660	DE660JJ	NJ3	51.50	43.40	66.00	2900	F	SCD 10

For shielded units, please add the suffix "S" to the above part numbers. (i.e. DE075JJS)

*WALL MOUNTING KIT AND/OR DRIP PLATE KIT REQUIRED. REFER TO PAGES 271 TO 273 FOR DETAILS.

480 Delta Primary Volts

240Y Secondary Volts

60 Hz

kVA	Catalog Number	Case Style (Pages 260 - 267)	Dimensions			Approx. Weight (Lbs.)	Mtg Type W - Wall F - Floor	Wiring Diagram (Pages 276 - 288)
			Width	Depth	Height			
7.5	Outside of C802.2/TP1 guidelines, refer to Non-Energy Efficient Drive Isolation Transformers on page 124							
11	Outside of C802.2/TP1 guidelines, refer to Non-Energy Efficient Drive Isolation Transformers on page 124							
14	Outside of C802.2/TP1 guidelines, refer to Non-Energy Efficient Drive Isolation Transformers on page 124							
20	DE020KD	NH6	23.90	25.00	28.75	240	F or W *	SCD 7
27	DE027KD	NH6	23.90	25.00	28.75	300	F or W *	SCD 7
34	DE034KD	NH6	23.90	25.00	28.75	330	F or W *	SCD 7
40	DE040KD	NH6	23.90	25.00	28.75	350	F or W *	SCD 7
51	DE051KD	NH6	23.90	25.00	28.75	430	F or W *	SCD 7
63	DE063KD	NH3	26.00	25.00	38.00	530	F or W *	SCD 7
75	DE075KD	NH3	26.00	25.00	38.00	580	F or W *	SCD 7
93	DE093KD	NH3	26.00	25.00	38.00	630	F or W *	SCD 7
118	DE118KD	NH3	26.00	25.00	38.00	730	F or W *	SCD 7
145	DE145KD	NH4	32.00	29.50	41.00	830	F	SCD 7
175	DE175KD	NH4	32.00	29.50	41.00	930	F	SCD 7
220	DE220KD	NH4	32.00	29.50	41.00	1350	F	SCD 9
275	DE275KD	NJ1	39.50	34.00	51.50	1500	F	SCD 9
330	DE330KD	NJ1	39.50	34.00	51.50	1700	F	SCD 9
440	DE440KD	NJ2	48.50	38.40	59.00	2100	F	SCD 10
550	DE550KD	NJ2	48.50	38.40	59.00	2350	F	SCD 10
660	DE660KD	NJ3	51.50	43.40	66.00	2900	F	SCD 10

For shielded units, please add the suffix "S" to the above part numbers. (i.e. DE075KDS)

*WALL MOUNTING KIT AND/OR DRIP PLATE KIT REQUIRED. REFER TO PAGES 271 TO 273 FOR DETAILS.

Products listed on this page are available as 'CE Mark' products. Please consult our sales office.

FOR TERMINATION DETAILS SEE PAGE 142

FOR ACCESSORIES SEE PAGES 271 TO 274



Selection Tables



Listed below are our standard voltages. Other primary and secondary voltages available are 240, 380 and 600.

ALUMINUM WOUND, THREE PHASE

480 Delta Primary Volts

480Y Secondary Volts

60 Hz

kVA	Catalog Number	Case Style (Pages 260 - 267)	Dimensions			Approx. Weight (Lbs.)	Mtg Type W - Wall F - Floor	Wiring Diagram (Pages 276 - 288)
			Width	Depth	Height			
7.5	Outside of C802.2/TP1 guidelines, refer to Non-Energy Efficient Drive Isolation Transformers on page 125							
11	Outside of C802.2/TP1 guidelines, refer to Non-Energy Efficient Drive Isolation Transformers on page 125							
14	Outside of C802.2/TP1 guidelines, refer to Non-Energy Efficient Drive Isolation Transformers on page 125							
20	DE020KK	NH6	23.90	25.00	28.75	240	F or W *	SCD 7
27	DE027KK	NH6	23.90	25.00	28.75	300	F or W *	SCD 7
34	DE034KK	NH6	23.90	25.00	28.75	330	F or W *	SCD 7
40	DE040KK	NH6	23.90	25.00	28.75	350	F or W *	SCD 7
51	DE051KK	NH6	23.90	25.00	28.75	430	F or W *	SCD 7
63	DE063KK	NH3	26.00	25.00	38.00	530	F or W *	SCD 7
75	DE075KK	NH3	26.00	25.00	38.00	580	F or W *	SCD 7
93	DE093KK	NH3	26.00	25.00	38.00	630	F or W *	SCD 7
118	DE118KK	NH3	26.00	25.00	38.00	730	F or W *	SCD 7
145	DE145KK	NH4	32.00	29.50	41.00	830	F	SCD 7
175	DE175KK	NH4	32.00	29.50	41.00	930	F	SCD 7
220	DE220KK	NH4	32.00	29.50	41.00	1350	F	SCD 9
275	DE275KK	NJ1	39.50	34.00	51.50	1500	F	SCD 9
330	DE330KK	NJ1	39.50	34.00	51.50	1700	F	SCD 9
440	DE440KK	NJ2	48.50	38.40	59.00	2100	F	SCD 10
550	DE550KK	NJ2	48.50	38.40	59.00	2350	F	SCD 10
660	DE660KK	NJ3	51.50	43.40	66.00	2900	F	SCD 10

For shielded units, please add the suffix "S" to the above part numbers. (i.e. DE075KKS)

*WALL MOUNTING KIT AND/OR DRIP PLATE KIT REQUIRED. REFER TO PAGES 271 TO 273 FOR DETAILS.

575 Delta Primary Volts

460Y Secondary Volts

60 Hz

kVA	Catalog Number	Case Style (Pages 260 - 267)	Dimensions			Approx. Weight (Lbs.)	Mtg Type W - Wall F - Floor	Wiring Diagram (Pages 276 - 288)
			Width	Depth	Height			
7.5	Outside of C802.2/TP1 guidelines, refer to Non-Energy Efficient Drive Isolation Transformers on page 125							
11	Outside of C802.2/TP1 guidelines, refer to Non-Energy Efficient Drive Isolation Transformers on page 125							
14	Outside of C802.2/TP1 guidelines, refer to Non-Energy Efficient Drive Isolation Transformers on page 125							
20	DE020NJ	NH6	23.90	25.00	28.75	300	F or W *	SCD 7
27	DE027NJ	NH6	23.90	25.00	28.75	300	F or W *	SCD 7
34	DE034NJ	NH6	23.90	25.00	28.75	360	F or W *	SCD 7
40	DE040NJ	NH6	23.90	25.00	28.75	390	F or W *	SCD 7
51	DE051NJ	NH6	23.90	25.00	28.75	410	F or W *	SCD 7
63	DE063NJ	NH3	26.00	25.00	38.00	560	F or W *	SCD 7
75	DE075NJ	NH3	26.00	25.00	38.00	600	F or W *	SCD 7
93	DE093NJ	NH3	26.00	25.00	38.00	780	F or W *	SCD 7
118	DE118NJ	NH3	26.00	25.00	38.00	880	F or W *	SCD 7
145	DE145NJ	NH4	32.00	29.50	41.00	1050	F	SCD 7
175	DE175NJ	NH4	32.00	29.50	41.00	1200	F	SCD 7
220	DE220NJ	NJ1	39.50	34.00	51.50	1650	F	SCD 9
275	DE275NJ	NJ1	39.50	34.00	51.50	1900	F	SCD 9
330	DE330NJ	NJ1	39.50	34.00	51.50	2000	F	SCD 9
440	DE440NJ	NJ2	48.50	38.40	59.00	3000	F	SCD 10
550	DE550NJ	NJ2	48.50	38.40	59.00	3000	F	SCD 10
660	DE660NJ	NJ3	51.50	43.40	66.00	2900	F	SCD 10

For shielded units, please add the suffix "S" to the above part numbers. (i.e. DE075NJS)

*WALL MOUNTING KIT AND/OR DRIP PLATE KIT REQUIRED. REFER TO PAGES 271 TO 273 FOR DETAILS.

Products listed on this page are available as 'CE Mark' products. Please consult our sales office.

FOR TERMINATION DETAILS SEE PAGE 142

FOR ACCESSORIES SEE PAGES 271 TO 274



SECTION 4

Selection Tables



Listed below are our standard voltages. Other primary and secondary voltages available are 240, 380 and 600.

ALUMINUM WOUND, THREE PHASE

575 Delta Primary Volts

575Y Secondary Volts

60 Hz

kVA	Catalog Number	Case Style (Pages 260 - 267)	Dimensions			Approx. Weight (Lbs.)	Mtg Type W - Wall F - Floor	Wiring Diagram (Pages 276 - 288)
			Width	Depth	Height			
7.5	Outside of C802.2/TP1 guidelines, refer to Non-Energy Efficient Drive Isolation Transformers on page 126							
11	Outside of C802.2/TP1 guidelines, refer to Non-Energy Efficient Drive Isolation Transformers on page 126							
14	Outside of C802.2/TP1 guidelines, refer to Non-Energy Efficient Drive Isolation Transformers on page 126							
20	DE020NN	NH6	23.90	25.00	28.75	240	F or W *	SCD 7
27	DE027NN	NH6	23.90	25.00	28.75	300	F or W *	SCD 7
34	DE034NN	NH6	23.90	25.00	28.75	330	F or W *	SCD 7
40	DE040NN	NH6	23.90	25.00	28.75	350	F or W *	SCD 7
51	DE051NN	NH6	23.90	25.00	28.75	430	F or W *	SCD 7
63	DE063NN	NH3	26.00	25.00	38.00	530	F or W *	SCD 7
75	DE075NN	NH3	26.00	25.00	38.00	580	F or W *	SCD 7
93	DE093NN	NH3	26.00	25.00	38.00	630	F or W *	SCD 7
118	DE118NN	NH3	26.00	25.00	38.00	730	F or W *	SCD 7
145	DE145NN	NH4	32.00	29.50	41.00	830	F	SCD 7
175	DE175NN	NH4	32.00	29.50	41.00	930	F	SCD 7
220	DE220NN	NH4	32.00	29.50	41.00	1350	F	SCD 9
275	DE275NN	NJ1	39.50	34.00	51.50	1500	F	SCD 9
330	DE330NN	NJ1	39.50	34.00	51.50	1700	F	SCD 9
440	DE440NN	NJ2	48.50	38.40	59.00	2100	F	SCD 10
550	DE550NN	NJ2	48.50	38.40	59.00	2350	F	SCD 10
660	DE660NN	NJ3	51.50	43.40	66.00	2900	F	SCD 10

For shielded units, please add the suffix "S" to the above part numbers. (i.e. DE075NNS)

*WALL MOUNTING KIT AND/OR DRIP PLATE KIT REQUIRED. REFER TO PAGES 271 TO 273 FOR DETAILS.

COPPER WOUND, THREE PHASE

208 Delta Primary Volts

480Y Secondary Volts

60 Hz

kVA	Catalog Number	Case Style (Pages 260 - 267)	Dimensions			Approx. Weight (Lbs.)	Mtg Type W - Wall F - Floor	Wiring Diagram (Pages 276 - 288)
			Width	Depth	Height			
7.5	Outside of C802.2/TP1 guidelines, refer to Non-Energy Efficient Drive Isolation Transformers on page 126							
11	Outside of C802.2/TP1 guidelines, refer to Non-Energy Efficient Drive Isolation Transformers on page 126							
14	Outside of C802.2/TP1 guidelines, refer to Non-Energy Efficient Drive Isolation Transformers on page 126							
20	DE020BKC	NH6	23.90	25.00	28.75	270	F or W *	SCD 7
27	DE027BKC	NH6	23.90	25.00	28.75	330	F or W *	SCD 7
34	DE034BKC	NH6	23.90	25.00	28.75	350	F or W *	SCD 7
40	DE040BKC	NH6	23.90	25.00	28.75	380	F or W *	SCD 7
51	DE051BKC	NH6	23.90	25.00	28.75	450	F or W *	SCD 7
63	DE063BKC	NH3	26.00	25.00	38.00	550	F or W *	SCD 7
75	DE075BKC	NH3	26.00	25.00	38.00	600	F or W *	SCD 7
93	DE093BKC	NH3	26.00	25.00	38.00	630	F or W *	SCD 7
118	DE118BKC	NH3	26.00	25.00	38.00	880	F	SCD 7
145	DE145BKC	NH4	32.00	29.50	41.00	930	F	SCD 7
175	DE175BKC	NH4	32.00	29.50	41.00	1100	F	SCD 7
220	DE220BKC	NH4	32.00	29.50	41.00	1450	F	SCD 9
275	DE275BKC	NJ1	39.50	34.00	51.50	1680	F	SCD 9
330	DE330BKC	NJ1	39.50	34.00	51.50	1850	F	SCD 9
440	DE440BKC	NJ2	48.50	38.40	59.00	2350	F	SCD 10
550	DE550BKC	NJ2	48.50	38.40	59.00	2800	F	SCD 10
660	DE660BKC	NJ3	51.50	43.40	66.00	3250	F	SCD 10

For shielded units, please replace the suffix "C" with a 'K' on the above part numbers. (i.e. DE075BKK)

*WALL MOUNTING KIT AND/OR DRIP PLATE KIT REQUIRED. REFER TO PAGES 271 TO 273 FOR DETAILS.

Products listed on this page are available as 'CE Mark' products. Please consult our sales office.

FOR TERMINATION DETAILS SEE PAGE 142

FOR ACCESSORIES SEE PAGES 271 TO 274



Selection Tables



Listed below are our standard voltages. Other primary and secondary voltages available are 240, 380 and 600.

COPPER WOUND, THREE PHASE

230 Delta Primary Volts

230Y Secondary Volts

60 Hz

kVA	Catalog Number	Case Style (Pages 260 - 267)	Dimensions			Approx. Weight (Lbs.)	Mtg Type W - Wall F - Floor	Wiring Diagram (Pages 276 - 288)
			Width	Depth	Height			
7.5	Outside of C802.2/TP1 guidelines, refer to Non-Energy Efficient Drive Isolation Transformers on page 127							
11	Outside of C802.2/TP1 guidelines, refer to Non-Energy Efficient Drive Isolation Transformers on page 127							
14	Outside of C802.2/TP1 guidelines, refer to Non-Energy Efficient Drive Isolation Transformers on page 127							
20	DE020CCC	NH6	23.90	25.00	28.75	270	F or W *	SCD 7
27	DE027CCC	NH6	23.90	25.00	28.75	330	F or W *	SCD 7
34	DE034CCC	NH6	23.90	25.00	28.75	350	F or W *	SCD 7
40	DE040CCC	NH6	23.90	25.00	28.75	380	F or W *	SCD 7
51	DE051CCC	NH6	23.90	25.00	28.75	450	F or W *	SCD 7
63	DE063CCC	NH3	26.00	25.00	38.00	550	F or W *	SCD 7
75	DE075CCC	NH3	26.00	25.00	38.00	600	F or W *	SCD 7
93	DE093CCC	NH3	26.00	25.00	38.00	630	F or W *	SCD 7
118	DE118CCC	NH3	26.00	25.00	38.00	880	F	SCD 7
145	DE145CCC	NH4	32.00	29.50	41.00	930	F	SCD 7
175	DE175CCC	NH4	32.00	29.50	41.00	1100	F	SCD 7
220	DE220CCC	NH4	32.00	29.50	41.00	1450	F	SCD 9
275	DE275CCC	NJ1	39.50	34.00	51.50	1680	F	SCD 9
330	DE330CCC	NJ1	39.50	34.00	51.50	1850	F	SCD 9
440	DE440CCC	NJ2	48.50	38.40	59.00	2350	F	SCD 10
550	DE550CCC	NJ2	48.50	38.40	59.00	2800	F	SCD 10
660	DE660CCC	NJ3	51.50	43.40	66.00	3250	F	SCD 10

For shielded units, please replace the suffix "C" with a 'K' on the above part numbers. (i.e. DE075CCK)

*WALL MOUNTING KIT AND/OR DRIP PLATE KIT REQUIRED. REFER TO PAGES 271 TO 273 FOR DETAILS.

460 Delta Primary Volts

230Y Secondary Volts

60 Hz

kVA	Catalog Number	Case Style (Pages 260 - 267)	Dimensions			Approx. Weight (Lbs.)	Mtg Type W - Wall F - Floor	Wiring Diagram (Pages 276 - 288)
			Width	Depth	Height			
7.5	Outside of C802.2/TP1 guidelines, refer to Non-Energy Efficient Drive Isolation Transformers on page 127							
11	Outside of C802.2/TP1 guidelines, refer to Non-Energy Efficient Drive Isolation Transformers on page 127							
14	Outside of C802.2/TP1 guidelines, refer to Non-Energy Efficient Drive Isolation Transformers on page 127							
20	DE020JCCN	NH6	23.90	25.00	28.75	270	F or W *	SCD 7
27	DE027JCCN	NH6	23.90	25.00	28.75	330	F or W *	SCD 7
34	DE034JCC	NH6	23.90	25.00	28.75	350	F or W *	SCD 7
40	DE040JCC	NH6	23.90	25.00	28.75	380	F or W *	SCD 7
51	DE051JCC	NH6	23.90	25.00	28.75	450	F or W *	SCD 7
63	DE063JCC	NH3	26.00	25.00	38.00	550	F or W *	SCD 7
75	DE075JCC	NH3	26.00	25.00	38.00	600	F or W *	SCD 7
93	DE093JCC	NH3	26.00	25.00	38.00	630	F or W *	SCD 7
118	DE118JCC	NH3	26.00	25.00	38.00	880	F	SCD 7
145	DE145JCC	NH4	32.00	29.50	41.00	930	F	SCD 7
175	DE175JCC	NH4	32.00	29.50	41.00	1100	F	SCD 7
220	DE220JCC	NH4	32.00	29.50	41.00	1450	F	SCD 9
275	DE275JCC	NJ1	39.50	34.00	51.50	1680	F	SCD 9
330	DE330JCC	NJ1	39.50	34.00	51.50	1850	F	SCD 9
440	DE440JCC	NJ2	48.50	38.40	59.00	2350	F	SCD 10
550	DE550JCC	NJ2	48.50	38.40	59.00	2800	F	SCD 10
660	DE660JCC	NJ3	51.50	43.40	66.00	3250	F	SCD 10

For shielded units, please replace the suffix "C" with a 'K' on the above part numbers. (i.e. DE075JCK)

*WALL MOUNTING KIT AND/OR DRIP PLATE KIT REQUIRED. REFER TO PAGES 271 TO 273 FOR DETAILS.

Products listed on this page are available as 'CE Mark' products. Please consult our sales office.

FOR TERMINATION DETAILS SEE PAGE 142

FOR ACCESSORIES SEE PAGES 271 TO 274



SECTION 4

Selection Tables



Listed below are our standard voltages. Other primary and secondary voltages available are 240, 380 and 600.

COPPER WOUND, THREE PHASE

460 Delta Primary Volts

400Y Secondary Volts

60 Hz

kVA	Catalog Number	Case Style (Pages 260 - 267)	Dimensions			Approx. Weight (Lbs.)	Mtg Type W - Wall F - Floor	Wiring Diagram (Pages 276 - 288)
			Width	Depth	Height			
7.5	Outside of C802.2/TP1 guidelines, refer to Non-Energy Efficient Drive Isolation Transformers on page 128							
11	Outside of C802.2/TP1 guidelines, refer to Non-Energy Efficient Drive Isolation Transformers on page 128							
14	Outside of C802.2/TP1 guidelines, refer to Non-Energy Efficient Drive Isolation Transformers on page 128							
20	DE020JHCN	NH6	23.90	25.00	28.75	270	F or W *	SCD 7
27	DE027JHCN	NH6	23.90	25.00	28.75	330	F or W *	SCD 7
34	DE034JHC	NH6	23.90	25.00	28.75	350	F or W *	SCD 7
40	DE040JHC	NH6	23.90	25.00	28.75	380	F or W *	SCD 7
51	DE051JHC	NH6	23.90	25.00	28.75	450	F or W *	SCD 7
63	DE063JHC	NH3	26.00	25.00	38.00	550	F or W *	SCD 7
75	DE075JHC	NH3	26.00	25.00	38.00	600	F or W *	SCD 7
93	DE093JHC	NH3	26.00	25.00	38.00	630	F or W *	SCD 7
118	DE118JHC	NH3	26.00	25.00	38.00	880	F	SCD 7
145	DE145JHC	NH4	32.00	29.50	41.00	930	F	SCD 7
175	DE175JHC	NH4	32.00	29.50	41.00	1100	F	SCD 7
220	DE220JHC	NH4	32.00	29.50	41.00	1450	F	SCD 9
275	DE275JHC	NJ1	39.50	34.00	51.50	1680	F	SCD 9
330	DE330JHC	NJ1	39.50	34.00	51.50	1850	F	SCD 9
440	DE440JHC	NJ2	48.50	38.40	59.00	2350	F	SCD 10
550	DE550JHC	NJ2	48.50	38.40	59.00	2800	F	SCD 10
660	DE660JHC	NJ3	51.50	43.40	66.00	3250	F	SCD 10

For shielded units, please replace the suffix "C" with a 'K' on the above part numbers. (i.e. DE075JHK)

*WALL MOUNTING KIT AND/OR DRIP PLATE KIT REQUIRED. REFER TO PAGES 271 TO 273 FOR DETAILS.

460 Delta Primary Volts

460Y Secondary Volts

60 Hz

kVA	Catalog Number	Case Style (Pages 260 - 267)	Dimensions			Approx. Weight (Lbs.)	Mtg Type W - Wall F - Floor	Wiring Diagram (Pages 276 - 288)
			Width	Depth	Height			
7.5	Outside of C802.2/TP1 guidelines, refer to Non-Energy Efficient Drive Isolation Transformers on page 128							
11	Outside of C802.2/TP1 guidelines, refer to Non-Energy Efficient Drive Isolation Transformers on page 128							
14	Outside of C802.2/TP1 guidelines, refer to Non-Energy Efficient Drive Isolation Transformers on page 128							
20	DE020JJC	NH6	23.90	25.00	28.75	270	F or W *	SCD 7
27	DE027JJC	NH6	23.90	25.00	28.75	330	F or W *	SCD 7
34	DE034JJC	NH6	23.90	25.00	28.75	350	F or W *	SCD 7
40	DE040JJC	NH6	23.90	25.00	28.75	380	F or W *	SCD 7
51	DE051JJC	NH6	23.90	25.00	28.75	450	F or W *	SCD 7
63	DE063JJC	NH3	26.00	25.00	38.00	550	F or W *	SCD 7
75	DE075JJC	NH3	26.00	25.00	38.00	600	F or W *	SCD 7
93	DE093JJC	NH3	26.00	25.00	38.00	630	F or W *	SCD 7
118	DE118JJC	NH3	26.00	25.00	38.00	880	F	SCD 7
145	DE145JJC	NH4	32.00	29.50	41.00	930	F	SCD 7
175	DE175JJC	NH4	32.00	29.50	41.00	1100	F	SCD 7
220	DE220JJC	NH4	32.00	29.50	41.00	1450	F	SCD 9
275	DE275JJC	NJ1	39.50	34.00	51.50	1680	F	SCD 9
330	DE330JJC	NJ1	39.50	34.00	51.50	1850	F	SCD 9
440	DE440JJC	NJ2	48.50	38.40	59.00	2350	F	SCD 10
550	DE550JJC	NJ2	48.50	38.40	59.00	2800	F	SCD 10
660	DE660JJC	NJ3	51.50	43.40	66.00	3250	F	SCD 10

For shielded units, please replace the suffix "C" with a 'K' on the above part numbers. (i.e. DE075JJK)

*WALL MOUNTING KIT AND/OR DRIP PLATE KIT REQUIRED. REFER TO PAGES 271 TO 273 FOR DETAILS.

Products listed on this page are available as 'CE Mark' products. Please consult our sales office.

FOR TERMINATION DETAILS SEE PAGE 142

FOR ACCESSORIES SEE PAGES 271 TO 274



Selection Tables



Listed below are our standard voltages. Other primary and secondary voltages available are 240, 380 and 600.

COPPER WOUND, THREE PHASE

480 Delta Primary Volts

240Y Secondary Volts

60 Hz

kVA	Catalog Number	Case Style (Pages 260 - 267)	Dimensions			Approx. Weight (Lbs.)	Mtg Type W - Wall F - Floor	Wiring Diagram (Pages 276 - 288)
			Width	Depth	Height			
7.5	Outside of C802.2/TP1 guidelines, refer to Non-Energy Efficient Drive Isolation Transformers on page 129							
11	Outside of C802.2/TP1 guidelines, refer to Non-Energy Efficient Drive Isolation Transformers on page 129							
14	Outside of C802.2/TP1 guidelines, refer to Non-Energy Efficient Drive Isolation Transformers on page 129							
20	DE020KDCN	NH6	23.90	25.00	28.75	270	F or W *	SCD 7
27	DE027KDCN	NH6	23.90	25.00	28.75	330	F or W *	SCD 7
34	DE034KDCN	NH6	23.90	25.00	28.75	350	F or W *	SCD 7
40	DE040KDC	NH6	23.90	25.00	28.75	380	F or W *	SCD 7
51	DE051KDC	NH6	23.90	25.00	28.75	450	F or W *	SCD 7
63	DE063KDC	NH3	26.00	25.00	38.00	550	F or W *	SCD 7
75	DE075KDC	NH3	26.00	25.00	38.00	600	F or W *	SCD 7
93	DE093KDC	NH3	26.00	25.00	38.00	630	F or W *	SCD 7
118	DE118KDC	NH3	26.00	25.00	38.00	880	F	SCD 7
145	DE145KDC	NH4	32.00	29.50	41.00	930	F	SCD 7
175	DE175KDC	NH4	32.00	29.50	41.00	1100	F	SCD 7
220	DE220KDC	NH4	32.00	29.50	41.00	1450	F	SCD 9
275	DE275KDC	NJ1	39.50	34.00	51.50	1680	F	SCD 9
330	DE330KDC	NJ1	39.50	34.00	51.50	1850	F	SCD 9
440	DE440KDC	NJ2	48.50	38.40	59.00	2350	F	SCD 10
550	DE550KDC	NJ2	48.50	38.40	59.00	2800	F	SCD 10
660	DE660KDC	NJ3	51.50	43.40	66.00	3250	F	SCD 10

For shielded units, please replace the suffix "C" with a 'K' on the above part numbers. (i.e. DE075KDK)

*WALL MOUNTING KIT AND/OR DRIP PLATE KIT REQUIRED. REFER TO PAGES 271 TO 273 FOR DETAILS.

480 Delta Primary Volts

480Y Secondary Volts

60 Hz

kVA	Catalog Number	Case Style (Pages 260 - 267)	Dimensions			Approx. Weight (Lbs.)	Mtg Type W - Wall F - Floor	Wiring Diagram (Pages 276 - 288)
			Width	Depth	Height			
7.5	Outside of C802.2/TP1 guidelines, refer to Non-Energy Efficient Drive Isolation Transformers on page 129							
11	Outside of C802.2/TP1 guidelines, refer to Non-Energy Efficient Drive Isolation Transformers on page 129							
14	Outside of C802.2/TP1 guidelines, refer to Non-Energy Efficient Drive Isolation Transformers on page 129							
20	DE020KKCN	NH6	23.90	25.00	28.75	270	F or W *	SCD 7
27	DE027KKCN	NH6	23.90	25.00	28.75	330	F or W *	SCD 7
34	DE034KKCN	NH6	23.90	25.00	28.75	350	F or W *	SCD 7
40	DE040KKC	NH6	23.90	25.00	28.75	380	F or W *	SCD 7
51	DE051KKC	NH6	23.90	25.00	28.75	450	F or W *	SCD 7
63	DE063KKC	NH3	26.00	25.00	38.00	550	F or W *	SCD 7
75	DE075KKC	NH3	26.00	25.00	38.00	600	F or W *	SCD 7
93	DE093KKC	NH3	26.00	25.00	38.00	630	F or W *	SCD 7
118	DE118KKC	NH3	26.00	25.00	38.00	880	F	SCD 7
145	DE145KKC	NH4	32.00	29.50	41.00	930	F	SCD 7
175	DE175KKC	NH4	32.00	29.50	41.00	1100	F	SCD 7
220	DE220KKC	NH4	32.00	29.50	41.00	1450	F	SCD 9
275	DE275KKC	NJ1	39.50	34.00	51.50	1680	F	SCD 9
330	DE330KKC	NJ1	39.50	34.00	51.50	1850	F	SCD 9
440	DE440KKC	NJ2	48.50	38.40	59.00	2350	F	SCD 10
550	DE550KKC	NJ2	48.50	38.40	59.00	2800	F	SCD 10
660	DE660KKC	NJ3	51.50	43.40	66.00	3250	F	SCD 10

For shielded units, please replace the suffix "C" with a 'K' on the above part numbers. (i.e. DE075KKK)

*WALL MOUNTING KIT AND/OR DRIP PLATE KIT REQUIRED. REFER TO PAGES 271 TO 273 FOR DETAILS.

SECTION 4



Selection Tables



Listed below are our standard voltages. Other primary and secondary voltages available are 240, 380 and 600.

COPPER WOUND, THREE PHASE

575 Delta Primary Volts

460Y Secondary Volts

60 Hz

kVA	Catalog Number	Case Style (Pages 260 - 267)	Dimensions			Approx. Weight (Lbs.)	Mtg Type W - Wall F - Floor	Wiring Diagram (Pages 276 - 288)
			Width	Depth	Height			
7.5	Outside of C802.2/TP1 guidelines, refer to Non-Energy Efficient Drive Isolation Transformers on page 130							
11	Outside of C802.2/TP1 guidelines, refer to Non-Energy Efficient Drive Isolation Transformers on page 130							
14	Outside of C802.2/TP1 guidelines, refer to Non-Energy Efficient Drive Isolation Transformers on page 130							
20	DE020NJC	NH6	23.90	25.00	28.75	270	F or W *	SCD 7
27	DE027NJC	NH6	23.90	25.00	28.75	330	F or W *	SCD 7
34	DE034NJC	NH6	23.90	25.00	28.75	350	F or W *	SCD 7
40	DE040NJC	NH6	23.90	25.00	28.75	380	F or W *	SCD 7
51	DE051NJC	NH6	23.90	25.00	28.75	450	F or W *	SCD 7
63	DE063NJC	NH3	26.00	25.00	38.00	550	F or W *	SCD 7
75	DE075NJC	NH3	26.00	25.00	38.00	600	F or W *	SCD 7
93	DE093NJC	NH3	26.00	25.00	38.00	630	F or W *	SCD 7
118	DE118NJC	NH3	26.00	25.00	38.00	880	F	SCD 7
145	DE145NJC	NH4	32.00	29.50	41.00	930	F	SCD 7
175	DE175NJC	NH4	32.00	29.50	41.00	1100	F	SCD 7
220	DE220NJC	NH4	32.00	29.50	41.00	1450	F	SCD 9
275	DE275NJC	NJ1	39.50	34.00	51.50	1680	F	SCD 9
330	DE330NJC	NJ1	39.50	34.00	51.50	1850	F	SCD 9
440	DE440NJC	NJ2	48.50	38.40	59.00	2350	F	SCD 10
550	DE550NJC	NJ2	48.50	38.40	59.00	2800	F	SCD 10
660	DE660NJC	NJ3	51.50	43.40	66.00	3250	F	SCD 10

For shielded units, please replace the suffix "C" with a 'K' on the above part numbers. (i.e. DE075NJK)

*WALL MOUNTING KIT AND/OR DRIP PLATE KIT REQUIRED. REFER TO PAGES 271 TO 273 FOR DETAILS.

575 Delta Primary Volts

575Y Secondary Volts

60 Hz

kVA	Catalog Number	Case Style (Pages 260 - 267)	Dimensions			Approx. Weight (Lbs.)	Mtg Type W - Wall F - Floor	Wiring Diagram (Pages 276 - 288)
			Width	Depth	Height			
7.5	Outside of C802.2/TP1 guidelines, refer to Non-Energy Efficient Drive Isolation Transformers on page 130							
11	Outside of C802.2/TP1 guidelines, refer to Non-Energy Efficient Drive Isolation Transformers on page 130							
14	Outside of C802.2/TP1 guidelines, refer to Non-Energy Efficient Drive Isolation Transformers on page 130							
20	DE020NNC	NH6	23.90	25.00	28.75	270	F or W *	SCD 7
27	DE027NNC	NH6	23.90	25.00	28.75	330	F or W *	SCD 7
34	DE034NNC	NH6	23.90	25.00	28.75	350	F or W *	SCD 7
40	DE040NNC	NH6	23.90	25.00	28.75	380	F or W *	SCD 7
51	DE051NNC	NH6	23.90	25.00	28.75	450	F or W *	SCD 7
63	DE063NNC	NH3	26.00	25.00	38.00	550	F or W *	SCD 7
75	DE075NNC	NH3	26.00	25.00	38.00	600	F or W *	SCD 7
93	DE093NNC	NH3	26.00	25.00	38.00	630	F or W *	SCD 7
118	DE118NNC	NH3	26.00	25.00	38.00	880	F	SCD 7
145	DE145NNC	NH4	32.00	29.50	41.00	930	F	SCD 7
175	DE175NNC	NH4	32.00	29.50	41.00	1100	F	SCD 7
220	DE220NNC	NH4	32.00	29.50	41.00	1450	F	SCD 9
275	DE275NNC	NJ1	39.50	34.00	51.50	1680	F	SCD 9
330	DE330NNC	NJ1	39.50	34.00	51.50	1850	F	SCD 9
440	DE440NNC	NJ2	48.50	38.40	59.00	2350	F	SCD 10
550	DE550NNC	NJ2	48.50	38.40	59.00	2800	F	SCD 10
660	DE660NNC	NJ3	51.50	43.40	66.00	3250	F	SCD 10

For shielded units, please replace the suffix "C" with a 'K' on the above part numbers. (i.e. DE075NNK)

*WALL MOUNTING KIT AND/OR DRIP PLATE KIT REQUIRED. REFER TO PAGES 271 TO 273 FOR DETAILS.

Products listed on this page are available as 'CE Mark' products. Please consult our sales office.

FOR TERMINATION DETAILS SEE PAGE 142

FOR ACCESSORIES SEE PAGES 271 TO 274

Data subject to change without notice.





TERMINATION DETAILS

THREE PHASE, ALUMINUM AND COPPER TERMINATION - LUGS OR PADS

kVA	VOLTAGE							
	208	230	240	380	460	480	575	600
7.5	Lugs	Lugs	Lugs	Lugs	Lugs	Lugs	Lugs	Lugs
11	Lugs	Lugs	Lugs	Lugs	Lugs	Lugs	Lugs	Lugs
14	Lugs	Lugs	Lugs	Lugs	Lugs	Lugs	Lugs	Lugs
20	Lugs	Lugs	Lugs	Lugs	Lugs	Lugs	Lugs	Lugs
27	Lugs	Lugs	Lugs	Lugs	Lugs	Lugs	Lugs	Lugs
34	Lugs	Lugs	Lugs	Lugs	Lugs	Lugs	Lugs	Lugs
40	Lugs	Lugs	Lugs	Lugs	Lugs	Lugs	Lugs	Lugs
51	Lugs	Lugs	Lugs	Lugs	Lugs	Lugs	Lugs	Lugs
63	Lugs	Lugs	Lugs	Lugs	Lugs	Lugs	Lugs	Lugs
75	Lugs	Lugs	Lugs	Lugs	Lugs	Lugs	Lugs	Lugs
93	Lugs	Lugs	Lugs	Lugs	Lugs	Lugs	Lugs	Lugs
118	Diagram 1A	Diagram 1A	Diagram 1A	Lugs	Lugs	Lugs	Lugs	Lugs
145	Diagram 1A	Diagram 1A	Diagram 1A	Lugs	Lugs	Lugs	Lugs	Lugs
175	Diagram 1A	Diagram 1A	Diagram 1A	Lugs	Lugs	Lugs	Lugs	Lugs
220	Diagram 2	Diagram 1A	Diagram 1A	Diagram 1A	Diagram 1A	Lugs	Lugs	Lugs
275	Diagram 2	Diagram 2	Diagram 2	Diagram 1A	Diagram 1A	Diagram 1A	Diagram 1A	Lugs
330	Diagram 2	Diagram 2	Diagram 2	Diagram 1A	Diagram 1A	Diagram 1A	Diagram 1A	Diagram 1A
440	Diagram 3	Diagram 3	Diagram 3	Diagram 2	Diagram 1A	Diagram 1A	Diagram 1A	Diagram 1A
550	Diagram 3	Diagram 3	Diagram 3	Diagram 2	Diagram 2	Diagram 2	Diagram 1A	Diagram 1A
660	Diagram 3	Diagram 3	Diagram 3	Diagram 3	Diagram 2	Diagram 2	Diagram 2	Diagram 2

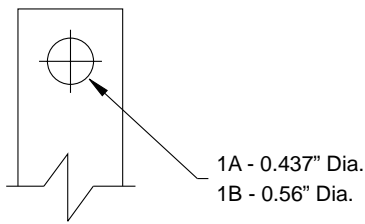

DIAGRAM 1

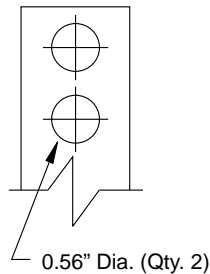

DIAGRAM 2

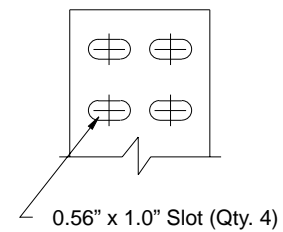

DIAGRAM 3

SECTION 4





SECTION 5

MOTOR STARTING AUTOTRANSFORMERS

Copper Wound Two Coil and Three Coil

Description and Applications	144
Copper Standard Specifications	145
Dimensional Drawings	145
Copper, Three Phase, 2 Coil Selection Tables	146
Copper, Three Phase, 3 Coil Selection Tables	147
Optional Thermostats	148

THREE PHASE MOTOR STARTING AUTOTRANSFORMERS

HPS 2A and 3A motor starting autotransformers have been an industry standard for many years. Autotransformers are a significant component of a motor controller. In its simplest form, motor starters start and stop a motor and protect against overvoltage and undervoltage. In most applications, a simple full-voltage magnetic starter places full voltage across the motor's windings on startup and maintains full voltage at the motor during the run mode.

For larger motors, or motors where the load is connected, the effect of motor-starting inrush can stress the electrical system with significantly lower currents in the distribution network. This can cause all manner of disruption to the system with subsequent interruption in the facility. In these cases, reduced-voltage starting must be applied. The addition of a motor starting autotransformer during the startup sequence limits the starting inrush current.

The 2A and 3A product line is designed for Medium Duty service including applications for drive loads such as pumps, compressors, conveyers and fans. Units are manufactured in accordance with NEMA Industrial Controls and Systems, Publication No. ICS-1970.

2A Motor Starting Autotransformer: Three phase, 2 coil, suitable for motor starters with 2 contacts, connected in an open 'V' configuration. Phase voltage across the open 'V' tends to be slightly out of balance when compared to the other two phases.

3A Motor Starting Autotransformer: Three phase, 3 coil, suitable for motor starters with 3 contacts, connected in a three phase 'Wye' configuration. This provides balanced voltages across each phase.

Special Motor Starting Autotransformers. For applications requiring heavy duty service with frequent starts or jogging, high inertia loads such as paper or steel mill drives, medium voltage or other unusual demands, HPS can offer specially designed units to meet your requirements. Please consult our sales offices.

TWO COIL

20 to 1600 HP



THREE COIL

25 to 1600 HP



SECTION 5 MOTOR STARTING AUTOTRANSFORMER

COPPER WOUND STANDARD SPECIFICATIONS



	TWO COIL	THREE COIL
	20 to 1600 HP	25 to 1600 HP
UL Listed	File: E61431	File: E61431
CSA Certified	File: LR3902	File: LR3902
Frequency	60 Hz	60 Hz
Insulation System	220°C	220°C
Standard Design	Three Phase, 2 Coil, using economical open core and coil construction.	Three Phase, 3 Coil, using economical open core and coil construction.
Standard Taps	All units have taps at 50%, 65% and 80%.	All units have taps at 50%, 65%, 80%
Termination	Heavy solid copper lugs with holes, provide reliable termination.	Heavy solid copper lugs with holes, provide reliable termination.
Thermostats	1 or 2 optional thermostats are available. (See page 148 for details.)	1, 2 or 3 optional thermostats are available. (See page 148 for details.)

DIMENSIONAL DRAWINGS

TWO COIL

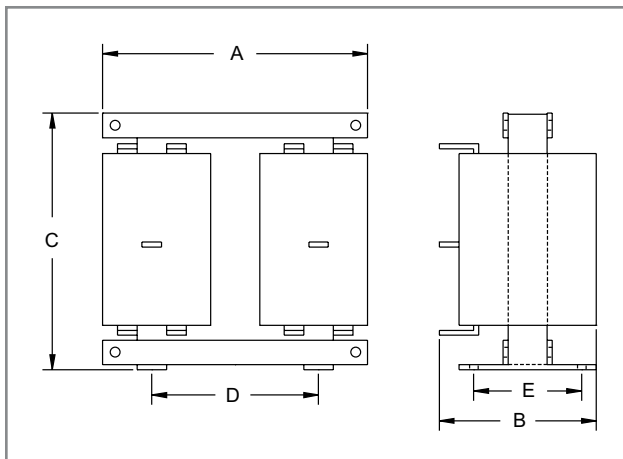

THREE COIL

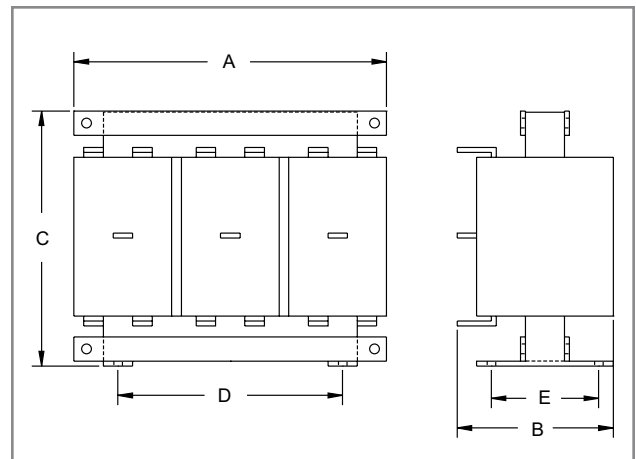

SECTION 5

SECTION 5 MOTOR STARTING AUTOTRANSFORMER

COPPER WOUND, THREE PHASE, TWO COIL



Two Coil - 240 Volts

60 Hz

HP	Voltage	Catalog Number	Dimensions			Mtg. Width D	Mtg. Depth E	Approx. Weight (Lbs.)
			A	B	C			
20/25	240	2909B.2	11.50	6.00	10.25	9.00	4.00	45
30/40	240	2909B.4	11.50	6.25	10.75	9.00	4.00	65
50	240	2909B.5	11.50	7.25	11.00	9.00	6.00	75
60/75	240	2909B.75	13.50	8.00	11.50	9.00	6.00	120
100	240	2909B1.	13.50	9.25	11.50	9.00	7.50	150
125/150	240	2909B1.5	14.50	10.00	12.75	9.00	7.50	190
200	240	2909B2.	14.50	10.50	12.75	9.00	7.50	220
250	240	2909B2.5	14.50	11.75	13.25	9.00	9.00	230
300	240	2909B3.	14.50	12.00	14.00	9.00	9.00	260
400	240	2909B4.	17.00	12.50	15.75	9.00	9.00	330
500	240	2909B5.	17.00	13.00	16.25	9.00	9.00	375
600	240	2909B6.	23.00	16.00	18.00	12.00	9.00	550
800	240	2909B8.	25.00	17.00	20.00	12.00	9.00	700
1000	240	2909B10.	26.00	18.00	22.00	12.00	9.00	800
1200	240	2909B12.	29.00	19.00	24.00	12.00	12.00	1050
1600	240	2909B16.	32.00	20.00	26.00	12.00	12.00	1350

Two Coil - 480 Volts

60 Hz

HP	Voltage	Catalog Number	Dimensions			Mtg. Width D	Mtg. Depth E	Approx. Weight (Lbs.)
			A	B	C			
20/25	480	2909C.2	11.50	6.00	10.25	9.00	4.00	45
30/40	480	2909C.4	11.50	6.25	10.75	9.00	4.00	65
50	480	2909C.5	11.50	7.25	11.00	9.00	6.00	75
60/75	480	2909C.75	13.50	8.00	11.50	9.00	6.00	120
100	480	2909C1.	13.50	9.25	11.50	9.00	7.50	150
125/150	480	2909C1.5	14.50	10.00	12.75	9.00	7.50	190
200	480	2909C2.	14.50	10.50	12.75	9.00	7.50	220
250	480	2909C2.5	14.50	11.75	13.25	9.00	9.00	230
300	480	2909C3.	14.50	12.00	14.00	9.00	9.00	260
400	480	2909C4.	17.00	12.50	15.75	9.00	9.00	330
500	480	2909C5.	17.00	13.00	16.25	9.00	9.00	375
600	480	2909C6.	23.00	16.00	18.00	12.00	9.00	550
800	480	2909C8.	25.00	17.00	20.00	12.00	9.00	700
1000	480	2909C10.	26.00	18.00	22.00	12.00	9.00	800
1200	480	2909C12.	29.00	19.00	24.00	12.00	12.00	1050
1600	480	2909C16.	32.00	20.00	26.00	12.00	12.00	1350

Two Coil - 600 Volts

60 Hz

HP	Voltage	Catalog Number	Dimensions			Mtg. Width D	Mtg. Depth E	Approx. Weight (Lbs.)
			A	B	C			
20/25	600	2909D.2	11.50	6.00	10.25	9.00	4.00	45
30/40	600	2909D.4	11.50	6.25	10.75	9.00	4.00	65
50	600	2909D.5	11.50	7.25	11.00	9.00	6.00	75
60/75	600	2909D.75	13.50	8.00	11.50	9.00	6.00	120
100	600	2909D1.	13.50	9.25	11.50	9.00	7.50	150
125/150	600	2909D1.5	14.50	10.00	12.75	9.00	7.50	190
200	600	2909D2.	14.50	10.50	12.75	9.00	7.50	220
250	600	2909D2.5	14.50	11.75	13.25	9.00	9.00	230
300	600	2909D3.	14.50	12.00	14.00	9.00	9.00	260
400	600	2909D4.	17.00	12.50	15.75	9.00	9.00	330
500	600	2909D5.	17.00	13.00	16.25	9.00	9.00	375
600	600	2909D6.	23.00	16.00	18.00	12.00	9.00	550
800	600	2909D8.	25.00	17.00	20.00	12.00	9.00	700
1000	600	2909D10.	26.00	18.00	22.00	12.00	9.00	800
1200	600	2909D12.	29.00	19.00	24.00	12.00	12.00	1050
1600	600	2909D16.	32.00	20.00	26.00	12.00	12.00	1350

Other voltages and 50Hz units are available upon request.

SECTION 5



SECTION 5 MOTOR STARTING AUTOTRANSFORMER

COPPER WOUND, THREE PHASE, THREE COIL



Three Coil - 240 Volts

60 Hz

HP	Voltage	Catalog Number	Dimensions			Mtg. Width D	Mtg. Depth E	Approx. Weight (Lbs.)
			A	B	C			
25/30	240	3009B.3	11.50	6.50	8.75	9.00	4.00	65
40/50	240	3009B.5	11.50	7.75	9.00	9.00	6.00	80
60/75	240	3009B.75	13.50	8.00	10.25	9.00	6.00	125
100	240	3009B1.	13.50	8.75	10.25	9.00	6.00	140
125/150	240	3009B1.5	14.50	10.00	10.75	9.00	7.00	165
200	240	3009B2.	15.00	10.50	10.75	9.00	7.00	210
250	240	3009B2.5	15.75	12.00	11.50	9.00	8.25	245
300	240	3009B3.	15.75	12.25	12.00	9.00	8.25	275
400	240	3009B4.	17.00	12.50	14.00	9.00	8.25	320
500	240	3009B5.	17.00	12.50	14.50	9.00	8.25	345
600	240	3009B6.	21.00	14.00	16.00	12.00	9.00	450
800	240	3009B8.	23.00	15.00	18.00	12.00	9.00	600
1000	240	3009B10.	24.00	16.00	20.00	12.00	9.00	700
1200	240	3009B12.	27.00	17.00	22.00	12.00	12.00	900
1600	240	3009B16.	30.00	18.00	24.00	12.00	12.00	1200

Three Coil - 480 Volts

60 Hz

HP	Voltage	Catalog Number	Dimensions			Mtg. Width D	Mtg. Depth E	Approx. Weight (Lbs.)
			A	B	C			
25/30	480	3009C.3	11.50	6.50	8.75	9.00	4.00	65
40/50	480	3009C.5	11.50	7.75	9.00	9.00	6.00	80
60/75	480	3009C.75	13.50	8.00	10.25	9.00	6.00	125
100	480	3009C1.	13.50	8.75	10.25	9.00	6.00	140
125/150	480	3009C1.5	14.50	10.00	10.75	9.00	7.00	165
200	480	3009C2.	15.00	10.50	10.75	9.00	7.00	210
250	480	3009C2.5	15.75	12.00	11.50	9.00	8.25	245
300	480	3009C3.	15.75	12.25	12.00	9.00	8.25	275
400	480	3009C4.	17.00	12.50	14.00	9.00	8.25	320
500	480	3009C5.	17.00	12.50	14.50	9.00	8.25	345
600	480	3009C6.	21.00	14.00	16.00	12.00	9.00	450
800	480	3009C8.	23.00	15.00	18.00	12.00	9.00	600
1000	480	3009C10.	24.00	16.00	20.00	12.00	9.00	700
1200	480	3009C12.	27.00	17.00	22.00	12.00	12.00	900
1600	480	3009C16.	30.00	18.00	24.00	12.00	12.00	1200

Three Coil - 600 Volts

60 Hz

HP	Voltage	Catalog Number	Dimensions			Mtg. Width D	Mtg. Depth E	Approx. Weight (Lbs.)
			A	B	C			
25/30	600	3009D.3	11.50	6.50	8.75	9.00	4.00	65
40/50	600	3009D.5	11.50	7.75	9.00	9.00	6.00	80
60/75	600	3009D.75	13.50	8.00	10.25	9.00	6.00	125
100	600	3009D1.	13.50	8.75	10.25	9.00	6.00	140
125/150	600	3009D1.5	14.50	10.00	10.75	9.00	7.00	165
200	600	3009D2.	15.00	10.50	10.75	9.00	7.00	210
250	600	3009D2.5	15.75	12.00	11.50	9.00	8.25	245
300	600	3009D3.	15.75	12.25	12.00	9.00	8.25	275
400	600	3009D4.	17.00	12.50	14.00	9.00	8.25	320
500	600	3009D5.	17.00	12.50	14.50	9.00	8.25	345
600	600	3009D6.	21.00	14.00	16.00	12.00	9.00	450
800	600	3009D8.	23.00	15.00	18.00	12.00	9.00	600
1000	600	3009D10.	24.00	16.00	20.00	12.00	9.00	700
1200	600	3009D12.	27.00	17.00	22.00	12.00	12.00	900
1600	600	3009D16.	30.00	18.00	24.00	12.00	12.00	1200

SECTION 5



OPTIONAL THERMOSTATS



All HPS Motor Starting Autotransformers are available with optional thermostats. Thermostats are supplied with normally closed contacts and will provide a corresponding signal when coil temperatures exceed safe operating conditions. Each thermostat installed is supplied with standard leads.

Two Coil - Thermostat Options

Part Number	Description	Installation
T1	One Thermostat	Single thermostat installed in the left coil.
T2	Two Thermostats	One thermostat installed in both coils.



Three Coil - Thermostat Options

Part Number	Description	Installation
T1	One Thermostat	Single thermostat installed in the center coil.
T2	Two Thermostats	One thermostat installed in the left hand coil and one installed in the right coil.
T3	Three Thermostats	One thermostat installed in each of the three coils.





SECTION 6

HPS UNIVERSAL™ LOW VOLTAGE LIGHTING TRANSFORMERS

Encapsulated Single Phase Enclosed

Single Phase Applications & Standard Specifications..	150
Group A Selection Table	151
Group B Selection Table	151
Group C Selection Table	152
Enclosure Drawings	262

SINGLE PHASE LOW VOLTAGE TRANSFORMER APPLICATIONS

For a cost effective approach to supply low voltage for Recreational, Lighting, Light Duty Industrial and Pool and Spa applications or for a general purpose load including actuating relays, bells, control and low voltage circuits, these NEMA 3R style encapsulated transformers are specifically designed for the following applications;

- General purpose applications used to adjust a supply voltage to match load equipment.
- Supplying machine tool circuits.
- Actuating relays, bells, signal and alarm systems.
- Operating small motors, valves and dampers.
- Industrial lighting and circuit isolation.
- Pool and Spa (Must be ordered in a NEMA 4X stainless steel enclosure. Only available up to 1000VA as 60 Hz unit.)

HPS single phase encapsulated control transformers, with ratings from 50VA up to 5000VA in three voltage ratings, feature the newest technology and manufacturing processes.



LOW VOLTAGE LIGHTING TRANSFORMER STANDARD SPECIFICATIONS

	15 to 333 kVA	15 to 1500 kVA
UL Listed	File: E50394	File: E50394
CSA Certified	File: LR3902	File: LR3902
Frequency	50/60 Hz	50/60 Hz
Insulation System	130°C (80°C rise)	180°C (115°C rise)
Standard Design	Single Phase, core construction made with high quality, high permeability silicon steel laminations. Computer designed coils are accurately wound from high quality copper magnetic wire.	Single Phase, core construction made with high quality, high permeability silicon steel laminations. Computer designed coils are accurately wound from high quality copper magnetic wire.
Encapsulation	All units from 50VA to 5kVA are encapsulated with electrical grade silica sand and resin compounds.	All units from 50VA to 5kVA are encapsulated with electrical grade silica sand and resin compounds.
Enclosure Type	Heavy Duty Encapsulated NEMA Type 3R optional NEMA 4, 4X(stainless) & 12 available	Heavy Duty Encapsulated NEMA Type 3R optional NEMA 4, 4X(stainless) & 12 available
Termination	ANSI 61 Grey, UL50	ANSI 61 Grey, UL50
Conduit Knock-Outs	Side and Rear standard on all units.	Side and Rear standard on all units.
Mounting	Standard Wall Mounting.	Standard Wall Mounting.

SECTION 6



Single Phase Specification Tables

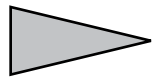

Group A

Primary Voltage	120/240
Secondary Voltage	12/24
50/60 Hertz	

VA	Catalog Number	Case Style (Pages 262)	Approx. Dimensions (Inches)			Approx. Weight (Lbs.)	Mtg Type W - Wall	Wiring Diagram (Pages 276)
			Width	Depth	Height			
50	QC05ERCB	NQ0	3.75	5.25	7.25	6	W	SCD 1
100	QC10ERCB	NQ0	3.75	5.25	7.25	7	W	SCD 1
150	QC15ERCB	NQ0	3.75	5.25	7.25	8	W	SCD 1
200	QC20ERCB	NQ1	4.50	5.75	7.25	11	W	SCD 1
250	QC25ERCB	NQ1	4.50	5.75	7.25	13	W	SCD 1
350	QC35ERCB	NQ1	4.50	5.75	7.25	14	W	SCD 1
500	QC50ERCB	NQ2	5.00	4.75	9.25	15	W	SCD 1
750	QC75ERCB	NQ2	5.00	4.75	9.25	18	W	SCD 1
1000	Q1C0ERCB	NQ3	5.88	5.50	10.50	25	W	SCD 1
1500	Q1C5ERCF	NQ4	7.00	6.50	11.75	36	W	SCD 1
2000	Q002ERCF	NQ4	7.00	6.50	11.75	46	W	SCD 1
3000	Q003ERCF	NQ5	10.00	7.75	17.25	65	W	SCD 1
5000	Q005ERCF	NQ5	10.00	7.75	17.25	105	W	SCD 1

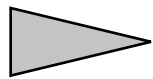

Group B

Primary Voltage	120/240
Secondary Voltage	16/32
50/60 Hertz	

VA	Catalog Number	Case Style (Pages 262)	Approx. Dimensions (Inches)			Approx. Weight (Lbs.)	Mtg Type W - Wall	Wiring Diagram (Pages 276)
			Width	Depth	Height			
50	QC05ESCB	NQ0	3.75	5.25	7.25	6	W	SCD 1
100	QC10ESCB	NQ0	3.75	5.25	7.25	7	W	SCD 1
150	QC15ESCB	NQ0	3.75	5.25	7.25	8	W	SCD 1
200	QC20ESCB	NQ1	4.50	5.75	7.25	11	W	SCD 1
250	QC25ESCB	NQ1	4.50	5.75	7.25	13	W	SCD 1
350	QC35ESCB	NQ1	4.50	5.75	7.25	14	W	SCD 1
500	QC50ESCB	NQ2	5.00	4.75	9.25	15	W	SCD 1
750	QC75ESCB	NQ2	5.00	4.75	9.25	18	W	SCD 1
1000	Q1C0ESCB	NQ3	5.88	5.50	10.50	25	W	SCD 1
1500	Q1C5ESCF	NQ4	7.00	6.50	11.75	36	W	SCD 1
2000	Q002ESCF	NQ4	7.00	6.50	11.75	46	W	SCD 1
3000	Q003ESCF	NQ5	10.00	7.75	17.25	65	W	SCD 1
5000	Q005ESCF	NQ5	10.00	7.75	17.25	105	W	SCD 1

SECTION 6



Single Phase Specification Tables



Group C	
Primary Voltage	240/480
Secondary Voltage	24/48
50/60 Hertz	

VA	Catalog Number	Case Style (Pages 262)	Approx. Dimensions (Inches)			Approx. Weight (Lbs.)	Mtg Type W - Wall	Wiring Diagram (Pages 276)
			Width	Depth	Height			
50	QC05DTCB	NQ0	3.75	5.25	7.25	6	W	SCD 1
100	QC10DTCB	NQ0	3.75	5.25	7.25	7	W	SCD 1
150	QC15DTCB	NQ0	3.75	5.25	7.25	8	W	SCD 1
200	QC20DTCB	NQ1	4.50	5.75	7.25	11	W	SCD 1
250	QC25DTCB	NQ1	4.50	5.75	7.25	13	W	SCD 1
350	QC35DTCB	NQ1	4.50	5.75	7.25	14	W	SCD 1
500	QC50DTCB	NQ2	5.00	4.75	9.25	15	W	SCD 1
750	QC75DTCB	NQ2	5.00	4.75	9.25	18	W	SCD 1
1000	Q1C0DTCB	NQ3	5.88	5.50	10.50	25	W	SCD 1
1500	Q1C5DTCF	NQ4	7.00	6.50	11.75	36	W	SCD 1
2000	Q002DTCF	NQ4	7.00	6.50	11.75	46	W	SCD 1
3000	Q003DTCF	NQ5	10.00	7.75	17.25	65	W	SCD 1
5000	Q005DTCF	NQ5	10.00	7.75	17.25	105	W	SCD 1



SECTION 7

ENERGY EFFICIENT GENERAL PURPOSE LOW VOLTAGE DISTRIBUTION TRANSFORMERS

600V Class, Single Phase & Three Phase

Low Voltage Distribution Transformer Energy Efficiency Guidelines U.S.A.....	154
Low Voltage Distribution Transformer Energy Efficiency Guidelines Canada..	155
NEMA Premium® Efficiency Transformer Program.....	156
Product Features and Applications.....	157
Energy Efficient Distribution Transformer Product Summary	157
<u>HPS Sentinel® Series - Energy Efficient General Purpose Transformers</u>	
HPS Sentinel® - copper & aluminum, single & three phase	159
HPS SuperSentinel® - copper & aluminum, single & three phase	174
<u>HPS Synergy® Series - Energy Efficient K-Factor Transformers</u>	
K-Factor, Harmonics and Non-Linear Loads	189
HPS Synergy® - copper & aluminum, three phase	191
HPS SuperSynergy® - copper & aluminum, three phase	196
<u>HPS Centurion® Series - Energy Efficient Harmonic Mitigating Transformers</u>	
600V Class Harmonic Mitigating Transformer.....	202
HPS Centurion® - copper & aluminum, three phase	203
HPS SuperCenturion® - copper & aluminum, three phase	213
Enclosure Dimensional Drawings	260
Accessories - Enclosure Mounting Kits, Anti-Vibration Pads & Isolators	271
Termination Details	275

Low Voltage Distribution Transformer Energy Efficiency Guidelines

In the past several years, there has been an accelerated rate of change to introduce energy efficiency standards for transformers in North America. Many products have preceded the initiatives for transformers in an overall effort to optimize manufactured goods for environmental concerns. Governments are encouraging users to consider energy efficient products like dry-type transformers in an effort to help reduce carbon dioxide emissions.

In addition to the benefits to the environment, energy efficient transformers realize substantial savings in operating costs, thereby having a direct impact on the initial investment evaluated over a period of time.

United States - Energy Efficiency (DOE 10 CFR Part 431)

The laws in the U.S. state that all low voltage dry-type distribution transformers (as defined below) manufactured after January 1st, 2007, must meet the minimum energy efficiency standards outlined in DOE 10 CFR Part 431. The range of product covered by these standards are:

Voltage Rating	Primary Voltage	600 volt and below
	Secondary Voltage	600 volt and below
Dry-Type Rating	Single Phase	15-333 kVA
	Three Phase	15-1000 kVA
Frequency		60 Hz only

For transformers exempted from the DOE efficiency regulations please refer to the following DOE link:
http://www.access.gpo.gov/nara/cfr/waisidx_09/10cfr431_09.html

The HPS lines of 600 volt class energy efficient distribution transformers illustrated in this section, meet or exceed the minimum efficiencies required. These efficiencies are at their maximum at 35% of the nameplate rated load.

The standards covering 600 volt class energy efficiency in dry-type transformers in North America are outlined in DOE 10 CFR Part 431, "Energy Conservation Program for Commercial Equipment: Distribution Transformers Energy Conservation Standards; Final Rule". These specifications have carefully considered the total owning cost unique for industrial or commercial installations where the load factor is an integral part of the efficiency rating.

US Department of Energy DOE 10 CFR Part 431 Efficiency Levels Dry-Type Distribution Transformers - Low Voltage			
Single Phase		Three Phase	
kVA	Efficiency	kVA	Efficiency
15	97.70	15	97.00
25	98.00	30	97.50
37.5	98.20	45	97.70
50	98.30	75	98.00
75	98.50	112.5	98.20
100	98.60	150	98.30
167	98.70	225	98.50
250	98.80	300	98.60
333	98.90	500	98.70
		750	98.80
		1000	98.90

All efficiency values are at 35% of nameplate rated load



SECTION 7

Low Voltage Distribution Transformer Energy Efficiency Guidelines Continued...

Canada - Energy Efficiency (CSA C802.2)

The laws in Canada state that all low voltage dry-type distribution transformers (as defined below) manufactured after January 1st, 2005, must meet the minimum energy efficiency guidelines outlined by CSA C802.2 and referenced in the Canadian Energy Efficiency Act - Energy Efficiency Regulations (SOR/94-651). The range of product covered by these standards are:

Primary (high) Voltage		Up to 1.2 kV
Secondary (low) Voltage Line Current		Less than 4000 amps
Dry-Type Rating	Single Phase	15-333 kVA
	Three Phase	15-1000 kVA
Frequency		60 Hz only

For transformers exempted from the Canadian Efficiency Regulations please refer to the following link: <http://laws.justice.gc.ca/eng/sor-94-651/page-1.html> or: http://www.hammondpowersolutions.com/products/locate_by_product/energy_efficient_distribution_transformers/index.php

The HPS lines of 1.2 kV volt class energy efficient distribution transformers illustrated in this section, meet or exceed the minimum efficiencies required. These efficiencies are at their maximum at 35% of the nameplate kVA transformer capacity.

The specifications covering 1.2 kV volt class energy efficiency in transformers in Canada are outlined in the CSA Efficiency Standard Document C802, "Maximum Losses for Distribution, Power and Dry-Type Transformers" as referenced in the Canadian Energy Efficiency Act - Energy Efficiency Regulations (SOR/94-651). These specifications have carefully considered the total owning cost unique for industrial or commercial installations where the load factor is an integral part of the efficiency rating.

CSA Efficiency Standard Document C802.2 Efficiency Levels Dry-Type Distribution Transformers - <u>Low Voltage</u>			
Single Phase		Three Phase	
kVA	Efficiency	kVA	Efficiency
15	97.70	15	97.00
25	98.00	30	97.50
37.5	98.20	45	97.70
50	98.30	75	98.00
75	98.50	112.5	98.20
100	98.60	150	98.30
167	98.70	225	98.50
250	98.80	300	98.60
333	98.90	500	98.70
		750	98.80
		1000	98.90

All efficiency values are at 35% of nameplate rated load



NEMA Premium® Efficiency Transformer Program

The 1992 Energy Act was a significant evolution in regulating low voltage dry-type transformers for the reduction of national energy use. Market pressures, however, indicated that customers were interested in even higher efficiencies. However with no guidelines in place, many manufacturers started to offer a multitude of higher efficiency transformer products, most of these without a well defined consistent specification.

On June 9th, 2010 the National Electrical Manufacturers Association (NEMA) announced the initiation of the NEMA Premium® Efficiency Transformer Program, which will help utilities, commercial buildings, and industrial plants incorporate super high-efficiency electrical transformers into their operations.

NEMA originally set the standard for the efficiency of various types of distribution transformers with the publication of NEMA TP 1-2002 Guide for Determining Energy Efficiency for Distribution Transformers, which was later adopted by the U.S. Department of Energy (DOE) as the national energy-efficiency rule for low-voltage dry-type distribution transformers. The new NEMA Premium® Efficiency Transformer designation requires 30 percent fewer losses than existing DOE regulations (10 CFR 431) for low-voltage dry-type distribution transformers.

The transformers covered under the new program are typically used in commercial and industrial applications. However, some electric utilities are considering the NEMA program for their commercial and industrial energy-efficiency rebate programs. The adoption of this program will not only reduce energy consumption, but will also significantly reduce carbon dioxide emissions.

Hammond Power Solutions Inc (HPS) has already been offering super high efficiency transformer lines in the market for many years (the HPS SuperSentinel®, HPS SuperSynergy® and HPS SuperCenturion®). HPS has now updated these lines to meet the efficiency levels in the new NEMA Premium® Efficiency Transformer Program.

*For more information about the NEMA Premium® Efficiency Transformer Program, visit;
<http://www.nema.org/gov/energy/efficiency/premium/transformersProgram.cfm>*

Please Note; not all premium efficiency low voltage dry-type are the same and the user should closely look at the other design parameters that could affect their system performance.

As a Partner in the NEMA Premium® Efficiency Transformer Program, HPS has determined that the products indicated in this section with the NEMA Premium® logo meet the NEMA Premium® Efficiency guidelines for super high-efficiency. (NEMA Premium® is a trademark of National Electrical Manufacturers Association.)



Product Features and Applications:

HPS offers three lines of energy efficient distribution transformers:

Linear Load General Purpose Transformers (pages 159 to 188)

General purpose distribution transformers are rated for 600 volts and below. They are generally used for supplying appliance, lighting, heating, motorized machine and power loads from electrical distribution systems. They are either ventilated, totally enclosed, or encapsulated (potted). For non-linear loads, all standard DOE 10 CFR Part 431 distribution transformers have to be derated to allow for additional heat due to harmonic losses.

Non-Linear Load K-Factor Transformers (pages 189 to 201)

The use of k-factor distribution transformers has become a popular means of addressing harmonic related overheating problems where electronic ballasts, drives, personal computers, telecommunications equipment, broadcasting equipment and other similar power electronics are found in high concentrations. These non-linear loads generate harmonic currents which can substantially increase transformer losses. The k-rated transformer has a more rugged design intended to prevent failure due to overheating.

K-factor is defined as a ratio between the additional losses due to harmonics and the eddy current losses at 60Hz. It is used to specify transformers for non-linear loads. Transformers with a rated k-factor of 4, 13, 20 and other are available.

Harmonic Mitigating Transformers (pages 202 to 222)

Harmonic Mitigating transformers are superior to k-rated and general purpose transformers in that they reduce voltage distortion (flat-topping) and power losses due to current harmonics created by single-phase, non-linear loads such as computer equipment. Secondary windings are arranged to **cancel** zero sequence fluxes and eliminate primary winding circulating currents. They treat zero sequence harmonics (3rd, 9th and 15th) within the secondary windings and 5th and 7th harmonics upstream with appropriate phase shifting.

Dual output, phase shifting Harmonic Mitigating Transformers provide extremely low output voltage distortion and input current distortion even under severe non-linear load conditions (Data Centers, Internet Service Providers, Telecom Sites, Call Centers, Broadcasting Studios, etc.). Combining zero sequence flux cancellation with phase shifting treats 3rd, 5th, 7th, 9th, 15th, 17th and 19th harmonics within its secondary windings.

HPS Energy Efficient Distribution Transformer Product Offering:

Energy Efficient General Purpose Transformers:

Energy efficient general purpose transformers are designed for linear loads and are most frequently used for applications such as commercial buildings, which will supply a variety of general loads.

HPS SENTINEL® (PART NUMBER PREFIX NMK OR NMF)

- Meets **DOE 10 CFR Part 431** and **C802.2** efficiencies at **35%** of rated load.
- Efficiencies are calculated under a **linear load profile**.
- Copper and Aluminum Available.

HPS SUPERSENTINEL® (PART NUMBER PREFIX SMK OR SMF)

- **Exceeds DOE 10 CFR Part 431** and (if applicable) **CSA C802.2** efficiencies at **35%** of rated load.
- Efficiency performance will meet the **NEMA Premium®** guidelines; **30% lower losses** than DOE 10 CFR Part 431 and (if applicable) CSA C802.2 standards; when measured under a linear load profile.
- Copper and Aluminum Available.



HPS Energy Efficient Distribution Transformer Product Offering Continued...

Energy Efficient K-Factor Transformers:

HPS SYNERGY® (PART NUMBER PREFIX NMT)

Energy efficient k-factor transformers are designed to tolerate heating due to harmonics associated with non-linear loads. Harmonics can indicate their presence in a number of ways: overheating, device malfunctions, telephone interference; equipment vibration; and breakers tripping.

- Meets **DOE 10 CFR Part 431** and **C802.2** efficiencies at **35%** of rated load.
- Efficiencies are calculated under a **linear load profile**.
- Copper and Aluminum Available.

HPS SUPERSYNERGY® (PART NUMBER PREFIX SMT)

The HPS SuperSynergy energy efficient k-factor transformer exceeds DOE 10 CFR Part 431 and (if applicable) CSA C802.2 efficiencies over a range of linear loads. It will not only satisfy the necessity for running at k-factor modern building load types, but in addition, because of the increasing need for energy conservation, they are much more efficient than that of our standard energy efficient line.

- Efficiency performance will meet the **NEMA Premium®** guidelines; **30% lower losses** than DOE 10 CFR Part 431 and (if applicable) CSA C802.2 efficiency standards; when measured under a linear load profile at **35%** of rated load.
- Efficiency will meet or exceed DOE 10 CFR Part 431 and (if applicable) CSA C802.2 efficiency standards for linear load even at **50%** of rated load when measured under a **non-linear** load up to **K13**.
- Copper and Aluminum Available.



Energy Efficient Harmonic Mitigating Transformers:

The HPS Centurion energy efficient, harmonic mitigating transformer with zero sequence flux cancellation technology is specifically designed to treat the harmonics generated by computer equipment and other non-linear, power electronic loads.

Combining zero sequence flux cancellation with phase shifting treats 3rd, 5th, 7th, 9th, 15th, 17th and 19th, harmonics within its secondary windings. Typical applications of severe non-linear loading conditions include data centers, internet-service providers, telecom sites, call centers, broadcast centers, etc.

HPS CENTURION® (PART NUMBER PREFIX H1EM OR H2EM)

- Meets **DOE 10 CFR Part 431** and **C802.2** efficiencies at an operating range from **35% to 65%** of rated linear load.
- Meets **DOE 10 CFR Part 431** and **C802.2** efficiency standards when measured under a **non-linear** load profile up to **K20** in an operating range from **35% to 50%**.
- Copper & Aluminum Available.

HPS SUPERCENTURION® (PART NUMBER PREFIX S1EM OR S2EM)

- **Exceeds DOE 10 CFR Part 431** and (if applicable) **C802.2** efficiencies at **35%** of rated load.
- Efficiency performance will meet **NEMA Premium®** guidelines; **30% lower losses** than **DOE 10 CFR Part 431** and (if applicable) CSA C802.2 efficiency standards when measured under a linear load profile.
- Efficiencies will exceed **DOE 10 CFR Part 431** and (if applicable) CSA C802.2 standards at an operating range from **35% to 65%** of rated load when measured under a **non-linear** load profile up to **K20**.
- Copper & Aluminum Available.



HPS SENTINEL®**600 VOLT CLASS ENERGY EFFICIENT
GENERAL PURPOSE DISTRIBUTION TRANSFORMERS****General Purpose Distribution Transformer Efficiencies:**

Energy efficient general purpose transformers are designed for linear loads and are most frequently used for applications such as commercial buildings which will supply a variety of general loads.

HPS SENTINEL (PART NUMBER PREFIX NMK OR NMF)

- Meets **DOE 10 CFR Part 431** and **C802.2** efficiencies at **35%** of rated load.
- Efficiencies are calculated under a **linear load profile**.
- Copper and Aluminum Available.



HPS SENTINEL® 600 VOLT CLASS ENERGY EFFICIENT GENERAL PURPOSE DISTRIBUTION TRANSFORMERS

ALUMINUM & COPPER, SINGLE PHASE STANDARD SPECIFICATIONS

15 to 37.5 kVA

50 to 167 kVA



	15 to 37.5 kVA	50 to 167 kVA
Efficiency	Meets DOE 10 CFR Part 431 & C802.2 efficiencies at 35% of rated load. Efficiencies are calculated under a linear load profile.	
UL Listed	File: E112313	File: E112313
CSA Certified	File: LR3902	File: LR3902
Frequency	60 Hz	60 Hz
Insulation System	220°C (150°C rise) (optional 115°C and 80°C rise available)	220°C (150°C rise) (optional 115°C and 80°C rise available)
Enclosure Type	Heavy Duty Ventilated Type 3R Optional Type 4, 4X (stainless steel) and 12.	Heavy Duty Ventilated Type 3R Optional Type 4, 4X (stainless steel) and 12.
Enclosure Finish	ANSI 61 Grey, UL50	ANSI 61 Grey, UL50
Standard Primary Taps	Refer to wiring diagrams for details.	Refer to wiring diagrams for details.
Termination	Front accessible separate high and low voltage terminals; connectors suitable for aluminum and copper are provided for easy cable installation.	Front accessible separate high and low voltage terminals; connectors suitable for aluminum and copper are provided for easy cable installation.
Conduit Knock-Outs	Standard on all units.	Standard on 50 kVA, 75 kVA & 100 kVA units.
Impedance	Typically 2.5% to 6.5%	Typically 2.5% to 6.5%
Mounting	Floor or wall/ceiling mounting available. Refer to selection tables for details.	Floor or wall/ceiling mounting available. Refer to selection tables for details.
Seismic	Seismically certified in accordance with 2009 IBC for $S_{DS} \leq 2.00g$, $z/h = 1.0$ and $I_p = 1.5$	Seismically certified in accordance with 2009 IBC for $S_{DS} \leq 2.00g$, $z/h = 1.0$ and $I_p = 1.5$
Sound level	Meets NEMA ST-20 standards. (Optional low noise units available)	Meets NEMA ST-20 standards. (Optional low noise units available)

Other voltages and kVA sizes not listed in this section are available upon request for both aluminum and copper wound units. Standard features as listed above may differ. Please contact customer service for details, price and availability.

SECTION 7





ALUMINUM WOUND, SINGLE PHASE

208 Primary Volts

120/240 Secondary Volts

60 Hz

kVA	Catalog Number	Case Style (Pages 260 - 267)	Approx. Dimensions (Inches)			Approx. Weight (Lbs.)	Mtg Type W - Wall F - Floor	Wiring Diagram (Pages 276 - 288)
			Width	Depth	Height			
15	NMF015BE	NH5	19.40	20.20	21.50	170	F or W *	SCD 32
25	NMF025BE	NH6	23.90	25.00	28.75	220	F or W *	SCD 31
37.5	NMF037BE	NH6	23.90	25.00	28.75	260	F or W *	SCD 31
50	NMF050BE	NH3	26.00	25.00	38.00	375	F or W *	SCD 2
75	NMF075BE	NH3	26.00	25.00	38.00	500	F or W *	SCD 39
100	NMF100BE	NH4	32.00	29.50	41.00	650	F	SCD 39
150	NMF150BE	NJ4	32.00	32.50	50.00	850	F	SCD 39
167	NMF167BE	NJ4	32.00	32.50	50.00	950	F	SCD 39

For shielded units, please add the suffix "S" to the above part numbers.

*WALL MOUNTING KIT AND/OR DRIP PLATE KIT REQUIRED.
REFER TO PAGES 271 TO 273 FOR DETAILS.

240 X 480 Primary Volts

120/240 Secondary Volts

60 Hz

kVA	Catalog Number	Case Style (Pages 260 - 267)	Approx. Dimensions (Inches)			Approx. Weight (Lbs.)	Mtg Type W - Wall F - Floor	Wiring Diagram (Pages 276 - 288)
			Width	Depth	Height			
15	NMF015LE	NH5	19.40	20.20	21.50	170	F or W *	SCD 34
25	NMF025LE	NH6	23.90	25.00	28.75	220	F or W *	SCD 17
37.5	NMF037LE	NH6	23.90	25.00	28.75	260	F or W *	SCD 17
50	NMF050LE	NH3	26.00	25.00	38.00	370	F or W *	SCD 17
75	NMF075LE	NH3	26.00	25.00	38.00	500	F or W *	SCD 17
100	NMF100LE	NH4	32.00	29.50	41.00	650	F	SCD 17
150	NMF150LE	NJ4	32.00	32.50	50.00	850	F	SCD 17
167	NMF167LE	NJ4	32.00	32.50	50.00	900	F	SCD 17

For shielded units, please add the suffix "S" to the above part numbers.

*WALL MOUNTING KIT AND/OR DRIP PLATE KIT REQUIRED.
REFER TO PAGES 271 TO 273 FOR DETAILS.

277 Primary Volts

120/240 Secondary Volts

60 Hz

kVA	Catalog Number	Case Style (Pages 260 - 267)	Approx. Dimensions (Inches)			Approx. Weight (Lbs.)	Mtg Type W - Wall F - Floor	Wiring Diagram (Pages 276 - 288)
			Width	Depth	Height			
15	NMF015FE	NH5	19.40	20.20	21.50	170	F or W *	SCD 32
25	NMF025FE	NH6	23.90	25.00	28.75	260	F or W *	SCD 31
37.5	NMF037FE	NH6	23.90	25.00	28.75	400	F or W *	SCD 31
50	NMF050FE	NH3	26.00	25.00	38.00	450	F or W *	SCD 31
75	NMF075FE	NH3	26.00	25.00	38.00	650	F or W *	SCD 31
100	NMF100FE	NH4	32.00	29.50	41.00	700	F	SCD 39
150	NMF150FE	NJ4	32.00	32.50	50.00	830	F	SCD 39
167	NMF167FE	NJ4	32.00	32.50	50.00	880	F	SCD 39

For shielded units, please add the suffix "S" to the above part numbers.

*WALL MOUNTING KIT AND/OR DRIP PLATE KIT REQUIRED.
REFER TO PAGES 271 TO 273 FOR DETAILS.

Note: For units smaller than 15kVA, please refer to the single phase encapsulated units in Section 8.

Products listed on this page are available as 'CE Mark' products. Please consult our sales office.

FOR TERMINATION DETAILS SEE PAGE 275.

FOR ACCESSORIES SEE PAGES 271 TO 274.

Data subject to change without notice.





ALUMINUM WOUND, SINGLE PHASE

416 Primary Volts

120/240 Secondary Volts

60 Hz

kVA	Catalog Number	Case Style (Pages 260 - 267)	Approx. Dimensions (Inches)			Approx. Weight (Lbs.)	Mtg Type W - Wall F - Floor	Wiring Diagram (Pages 276 - 288)
			Width	Depth	Height			
15	NMF015HE	NH5	19.40	20.20	21.50	220	F or W *	SCD 32
25	NMF025HE	NH6	23.90	25.00	28.75	220	F or W *	SCD 31
37.5	NMF037HE	NH6	23.90	25.00	28.75	260	F or W *	SCD 31
50	NMF050HE	NH3	26.00	25.00	38.00	400	F or W *	SCD 31
75	NMF075HE	NH3	26.00	25.00	38.00	480	F or W *	SCD 31
100	NMF100HE	NH4	32.00	29.50	41.00	650	F	SCD 39
150	NMF150HE	NJ4	32.00	32.50	50.00	850	F	SCD 39
167	NMF167HE	NJ4	32.00	32.50	50.00	900	F	SCD 39

For shielded units, please add the suffix "S" to the above part numbers.

*WALL MOUNTING KIT AND/OR DRIP PLATE KIT REQUIRED. REFER TO PAGES 271 TO 273 FOR DETAILS.

600 Primary Volts

120/240 Secondary Volts

60 Hz

kVA	Catalog Number	Case Style (Pages 260 - 267)	Approx. Dimensions (Inches)			Approx. Weight (Lbs.)	Mtg Type W - Wall F - Floor	Wiring Diagram (Pages 276 - 288)
			Width	Depth	Height			
15	NMF015PE	NH5	19.40	20.20	21.50	220	F or W *	SCD 32
25	NMF025PE	NH6	23.90	25.00	28.75	220	F or W *	SCD 31
37.5	NMF037PE	NH6	23.90	25.00	28.75	260	F or W *	SCD 31
50	NMF050PE	NH3	26.00	25.00	38.00	400	F or W *	SCD 31
75	NMF075PE	NH3	26.00	25.00	38.00	480	F or W *	SCD 31
100	NMF100PE	NH4	32.00	29.50	41.00	650	F	SCD 39
150	NMF150PE	NJ4	32.00	32.50	50.00	850	F	SCD 39
167	NMF167PE	NJ4	32.00	32.50	50.00	900	F	SCD 39

For shielded units, please add the suffix "S" to the above part numbers.

*WALL MOUNTING KIT AND/OR DRIP PLATE KIT REQUIRED. REFER TO PAGES 271 TO 273 FOR DETAILS.

SINGLE PHASE, EXPORT MODEL

190/200/208/220 X 380/400/416/440 Primary Volts

120/240 Secondary Volts

50/60 Hz**

kVA	Catalog Number	Case Style (Pages 260 - 267)	Approx. Dimensions (Inches)			Approx. Weight (Lbs.)	Mtg Type W - Wall F - Floor	Wiring Diagram (Pages 276 - 288)
			Width	Depth	Height			
15	NMF015XE	NH6	23.90	25.00	28.75	190	F or W *	SCD 30
25	NMF025XE	NH6	23.90	25.00	28.75	240	F or W *	SCD 30
37.5	NMF037XE	NH6	23.90	25.00	28.75	300	F or W *	SCD 30
50	NMF050XE	NH3	26.00	25.00	38.00	390	F or W *	SCD 30
75	NMF075XE	NH3	26.00	25.00	38.00	540	F or W *	SCD 30
100	NMF100XE	NH4	32.00	29.50	41.00	700	F	SCD 30
150	NMF150XE	CONSULT FACTORY					F	SCD 30
167	NMF167XE	CONSULT FACTORY					F	SCD 30

For shielded units, please add the suffix "S" to the above part numbers.

**Note: Meets DOE 10 CFR Part 431 and C802.2 at 60 Hz.

*WALL MOUNTING KIT AND/OR DRIP PLATE KIT REQUIRED. REFER TO PAGES 271 TO 273 FOR DETAILS.

Note: For units smaller than 15kVA, please refer to the single phase encapsulated units in Section 8.

Products listed on this page are available as 'CE Mark' products. Please consult our sales office.

FOR TERMINATION DETAILS SEE PAGE 275.

FOR ACCESSORIES SEE PAGES 271 TO 274.

Data subject to change without notice.



SECTION 7

COPPER WOUND, SINGLE PHASE



208 Primary Volts

120/240 Secondary Volts

60 Hz

kVA	Catalog Number	Case Style (Pages 260 - 267)	Approx. Dimensions (Inches)			Approx. Weight (Lbs.)	Mtg Type W - Wall F - Floor	Wiring Diagram (Pages 276 - 288)
			Width	Depth	Height			
15	NMF015BEC	NH5	19.40	20.20	21.50	180	F or W *	SCD 32
25	NMF025BEC	NH6	23.90	25.00	28.75	240	F or W *	SCD 31
37.5	NMF037BEC	NH6	23.90	25.00	28.75	300	F or W *	SCD 31
50	NMF050BEC	NH3	26.00	25.00	38.00	375	F or W *	SCD 2
75	NMF075BEC	NH3	26.00	25.00	38.00	525	F or W *	SCD 31
100	NMF100BEC	NH4	32.00	29.50	41.00	650	F	SCD 39
150	NMF150BEC	NJ4	32.00	32.50	50.00	900	F	SCD 39
167	NMF167BEC	NJ4	32.00	32.50	50.00	1000	F	SCD 39

For shielded units, please replace the suffix "C" with a 'K' on the above part numbers.

*WALL MOUNTING KIT AND/OR DRIP PLATE KIT REQUIRED.
REFER TO PAGES 271 TO 273 FOR DETAILS.

240 X 480 Primary Volts

120/240 Secondary Volts

60 Hz

kVA	Catalog Number	Case Style (Pages 260 - 267)	Approx. Dimensions (Inches)			Approx. Weight (Lbs.)	Mtg Type W - Wall F - Floor	Wiring Diagram (Pages 276 - 288)
			Width	Depth	Height			
15	NMF015LEC	NH5	19.40	20.20	21.50	180	F or W *	SCD 34
25	NMF025LEC	NH6	23.90	25.00	28.75	240	F or W *	SCD 17
37.5	NMF037LEC	NH6	23.90	25.00	28.75	300	F or W *	SCD 17
50	NMF050LEC	NH3	26.00	25.00	38.00	375	F or W *	SCD 17
75	NMF075LEC	NH3	26.00	25.00	38.00	525	F or W *	SCD 17
100	NMF100LEC	NH4	32.00	29.50	41.00	650	F	SCD 17
150	NMF150LEC	NJ4	32.00	32.50	50.00	900	F	SCD 17
167	NMF167LEC	NJ4	32.00	32.50	50.00	1000	F	SCD 17

For shielded units, please replace the suffix "C" with a 'K' on the above part numbers.

*WALL MOUNTING KIT AND/OR DRIP PLATE KIT REQUIRED.
REFER TO PAGES 271 TO 273 FOR DETAILS.

277 Primary Volts

120/240 Secondary Volts

60 Hz

kVA	Catalog Number	Case Style (Pages 260 - 267)	Approx. Dimensions (Inches)			Approx. Weight (Lbs.)	Mtg Type W - Wall F - Floor	Wiring Diagram (Pages 276 - 288)
			Width	Depth	Height			
15	NMF015FEC	NH5	19.40	20.20	21.50	180	F or W *	SCD 32
25	NMF025FEC	NH6	23.90	25.00	28.75	240	F or W *	SCD 31
37.5	NMF037FEC	NH6	23.90	25.00	28.75	300	F or W *	SCD 31
50	NMF050FEC	NH3	26.00	25.00	38.00	375	F or W *	SCD 31
75	NMF075FEC	NH3	26.00	25.00	38.00	525	F or W *	SCD 31
100	NMF100FEC	NH4	32.00	29.50	41.00	650	F	SCD 39
150	NMF150FEC	NJ4	32.00	32.50	50.00	900	F	SCD 39
167	NMF167FEC	NJ4	32.00	32.50	50.00	1000	F	SCD 39

For shielded units, please replace the suffix "C" with a 'K' on the above part numbers.

*WALL MOUNTING KIT AND/OR DRIP PLATE KIT REQUIRED.
REFER TO PAGES 271 TO 273 FOR DETAILS.

Note: For units smaller than 15kVA, please refer to the single phase encapsulated units in Section 8.

Products listed on this page are available as 'CE Mark' products. Please consult our sales office.



FOR TERMINATION DETAILS SEE PAGE 275.

FOR ACCESSORIES SEE PAGES 271 TO 274.



COPPER WOUND, SINGLE PHASE



416 Primary Volts

120/240 Secondary Volts

60 Hz

kVA	Catalog Number	Case Style (Pages 260 - 267)	Approx. Dimensions (Inches)			Approx. Weight (Lbs.)	Mtg Type W - Wall F - Floor	Wiring Diagram (Pages 276 - 288)
			Width	Depth	Height			
15	NMF015HEC	NH5	19.40	20.20	21.50	180	F or W *	SCD 32
25	NMF025HEC	NH6	23.90	25.00	28.75	240	F or W *	SCD 31
37.5	NMF037HEC	NH6	23.90	25.00	28.75	300	F or W *	SCD 31
50	NMF050HEC	NH3	26.00	25.00	38.00	375	F or W *	SCD 31
75	NMF075HEC	NH3	26.00	25.00	38.00	525	F or W *	SCD 31
100	NMF100HEC	NH4	32.00	29.50	41.00	650	F	SCD 39
150	NMF150HEC	NJ4	32.00	32.50	50.00	900	F	SCD 39
167	NMF167HEC	NJ4	32.00	32.50	50.00	1000	F	SCD 39

For shielded units, please replace the suffix "C" with a 'K' on the above part numbers.

*WALL MOUNTING KIT AND/OR DRIP PLATE KIT REQUIRED. REFER TO PAGES 271 TO 273 FOR DETAILS.

600 Primary Volts

120/240 Secondary Volts

60 Hz

kVA	Catalog Number	Case Style (Pages 260 - 267)	Approx. Dimensions (Inches)			Approx. Weight (Lbs.)	Mtg Type W - Wall F - Floor	Wiring Diagram (Pages 276 - 288)
			Width	Depth	Height			
15	NMF015PEC	NH5	19.40	20.20	21.50	180	F or W *	SCD 32
25	NMF025PEC	NH6	23.90	25.00	28.75	240	F or W *	SCD 31
37.5	NMF037PEC	NH6	23.90	25.00	28.75	300	F or W *	SCD 31
50	NMF050PEC	NH3	26.00	25.00	38.00	375	F or W *	SCD 31
75	NMF075PEC	NH3	26.00	25.00	38.00	525	F or W *	SCD 31
100	NMF100PEC	NH4	32.00	29.50	41.00	650	F	SCD 39
150	NMF150PEC	NJ4	32.00	32.50	50.00	900	F	SCD 39
167	NMF167PEC	NJ4	32.00	32.50	50.00	1000	F	SCD 39

For shielded units, please replace the suffix "C" with a 'K' on the above part numbers.

*WALL MOUNTING KIT AND/OR DRIP PLATE KIT REQUIRED. REFER TO PAGES 271 TO 273 FOR DETAILS.

SINGLE PHASE, EXPORT MODEL

190/200/208/220 X 380/400/416/440 Primary Volts

120/240 Secondary Volts

50/60 Hz**

kVA	Catalog Number	Case Style (Pages 260 - 267)	Approx. Dimensions (Inches)			Approx. Weight (Lbs.)	Mtg Type W - Wall F - Floor	Wiring Diagram (Pages 276 - 288)
			Width	Depth	Height			
15	NMF015XEC	NH6	23.90	25.00	28.75	190	F or W *	SCD 30
25	NMF025XEC	NH6	23.90	25.00	28.75	240	F or W *	SCD 30
37.5	NMF037XEC	NH6	23.90	25.00	28.75	300	F or W *	SCD 30
50	NMF050XEC	NH3	26.00	25.00	38.00	390	F or W *	SCD 30
75	NMF075XEC	NH3	26.00	25.00	38.00	540	F or W *	SCD 30
100	NMF100XEC	NH4	32.00	29.50	41.00	700	F	SCD 30
150	NMF150XEC		CONSULT FACTORY				F	SCD 30
167	NMF167XEC		CONSULT FACTORY				F	SCD 30

For shielded units, please add the suffix "S" to the above part numbers.

**Note: Meets DOE 10 CFR Part 431 and C802.2 at 60 Hz.

*WALL MOUNTING KIT AND/OR DRIP PLATE KIT REQUIRED. REFER TO PAGES 271 TO 273 FOR DETAILS.

Note: For units smaller than 15kVA, please refer to the single phase encapsulated units in Section 8.

Products listed on this page are available as 'CE Mark' products. Please consult our sales office.

FOR TERMINATION DETAILS SEE PAGE 275.

FOR ACCESSORIES SEE PAGES 271 TO 274.



HPS SENTINEL® 600 VOLT CLASS ENERGY EFFICIENT GENERAL PURPOSE DISTRIBUTION TRANSFORMER

ALUMINUM & COPPER, THREE PHASE STANDARD SPECIFICATIONS

15 to 45 kVA



75 to 750 kVA



	15 to 45 kVA	75 to 750 kVA
Efficiency	Meets DOE 10 CRF Part 431 & C802.2 efficiencies at 35% of rated load. Efficiencies are calculated under a linear load profile.	
UL Listed	File: E112313	File: E112313
CSA Certified	File: LR3902	File: LR3902
Frequency	60 Hz	60 Hz
Insulation System	220°C (150°C rise) 200°C (130°C rise) on 15 & 30kVA copper (optional 115°C and 80°C rise available)	220°C (150°C rise) (optional 115°C and 80°C rise available)
Enclosure Type	Heavy Duty Ventilated Type 3R Optional Type 4, 4X (stainless steel) and 12.	Heavy Duty Ventilated Type 3R Optional Type 4, 4X (stainless steel) and 12.
Enclosure Finish	ANSI 61 Grey, UL50	ANSI 61 Grey, UL50
Neutral	Neutral terminal for field connection (on applicable units).	Neutral terminal for field connection (on applicable units).
Standard Primary Taps	Refer to wiring diagrams for details.	Refer to wiring diagrams for details.
Termination	Front accessible separate high and low voltage terminals; connectors suitable for aluminum and copper are provided for easy cable installation.	Front accessible separate high and low voltage terminals; connectors suitable for aluminum and copper are provided for easy cable installation.
Conduit Knock-Outs	Standard on all units.	Standard on 75 kVA & 150 kVA units.
Impedance	Typically 2.5% to 6.5%	Typically 2.5% to 6.5%
Mounting	Floor or wall/ceiling mounting available. Refer to selection tables for details.	Floor or wall/ceiling mounting available. Refer to selection tables for details.
Seismic	Seismically certified in accordance with 2009 IBC for $S_{DS} \leq 2.00g$, $z/h = 1.0$ and $I_p = 1.5$	Seismically certified in accordance with 2009 IBC for $S_{DS} \leq 2.00g$, $z/h = 1.0$ and $I_p = 1.5$
Sound level	Meets NEMA ST-20 standards. (Optional low noise units available)	Meets NEMA ST-20 standards. (Optional low noise units available)

Other voltages and kVA sizes not listed in this section are available upon request for both aluminum and copper wound units. Features as listed above may differ. Please contact customer service for details, price and availability.



ALUMINUM WOUND, THREE PHASE



208 Delta Primary Volts

208Y/120 Secondary Volts

60 Hz

kVA	Catalog Number	Case Style (Pages 260 - 267)	Approx. Dimensions (Inches)			Approx. Weight (Lbs.)	Mtg Type W - Wall F - Floor	Wiring Diagram (Pages 276 - 288)
			Width	Depth	Height			
15	NMK015BB	NH5	19.40	20.20	21.50	200	F or W *	SCD 7
30	NMK030BB	NH6	23.90	25.00	28.75	280	F or W *	SCD 9
45	NMK045BB	NH6	23.90	25.00	28.75	375	F or W *	SCD 9
75	NMK075BB	NH3	26.00	25.00	38.00	540	F or W *	SCD 9
112.5	NMK112BB	NH3	26.00	25.00	38.00	775	F or W *	SCD 9
150	NMK150BB	NH4	32.00	29.50	41.00	850	F	SCD 9
225	NMK225BB	NH4	32.00	29.50	41.00	1400	F	SCD 9
300	NMK300BB	NJ1	39.50	34.00	51.50	1700	F	SCD 9
500	NMK500BB	NJ2	48.50	38.40	59.00	2700	F	SCD 25
750	NMK750BB	NJ3	51.50	43.40	66.00	3250	F	SCD 25

For shielded units, please add the suffix "S" to the above part numbers.

*WALL MOUNTING KIT AND/OR DRIP PLATE KIT REQUIRED.
REFER TO PAGES 271 TO 273 FOR DETAILS.

208 Delta Primary Volts

480Y/277 Secondary Volts

60 Hz

kVA	Catalog Number	Case Style (Pages 260 - 267)	Approx. Dimensions (Inches)			Approx. Weight (Lbs.)	Mtg Type W - Wall F - Floor	Wiring Diagram (Pages 276 - 288)
			Width	Depth	Height			
15	NMK015BK	NH5	19.40	20.20	21.50	200	F or W *	SCD 40
30	NMK030BK	NH6	23.90	25.00	28.75	280	F or W *	SCD 26
45	NMK045BK	NH6	23.90	25.00	28.75	375	F or W *	SCD 26
75	NMK075BK	NH3	26.00	25.00	38.00	540	F or W *	SCD 26
112.5	NMK112BK	NH3	26.00	25.00	38.00	775	F or W *	SCD 26
150	NMK150BK	NH4	32.00	29.50	41.00	850	F	SCD 26
225	NMK225BK	NH4	32.00	29.50	41.00	1400	F	SCD 26
300	NMK300BK	NJ1	39.50	34.00	51.50	1700	F	SCD 26
500	NMK500BK	NJ2	48.50	38.40	59.00	2700	F	SCD 23
750	NMK750BK	NJ3	51.50	43.40	66.00	3250	F	SCD 40

For shielded units, please add the suffix "S" to the above part numbers.

*WALL MOUNTING KIT AND/OR DRIP PLATE KIT REQUIRED.
REFER TO PAGES 271 TO 273 FOR DETAILS.

240 Delta Primary Volts

208Y/120 Secondary Volts

60 Hz

kVA	Catalog Number	Case Style (Pages 260 - 267)	Approx. Dimensions (Inches)			Approx. Weight (Lbs.)	Mtg Type W - Wall F - Floor	Wiring Diagram (Pages 276 - 288)
			Width	Depth	Height			
15	NMK015DB	NH5	19.40	20.20	21.50	200	F or W *	SCD 25
30	NMK030DB	NH6	23.90	25.00	28.75	280	F or W *	SCD 9
45	NMK045DB	NH6	23.90	25.00	28.75	375	F or W *	SCD 9
75	NMK075DB	NH3	26.00	25.00	38.00	540	F or W *	SCD 9
112.5	NMK112DB	NH3	26.00	25.00	38.00	775	F or W *	SCD 9
150	NMK150DB	NH4	32.00	29.50	41.00	850	F	SCD 9
225	NMK225DB	NH4	32.00	29.50	41.00	1400	F	SCD 9
300	NMK300DB	NJ1	39.50	34.00	51.50	1700	F	SCD 9
500	NMK500DB	NJ2	48.50	38.40	59.00	2700	F	NO TAPS
750	NMK750DB	NJ3	51.50	43.40	66.00	3250	F	NO TAPS

For shielded units, please add the suffix "S" to the above part numbers.

*WALL MOUNTING KIT AND/OR DRIP PLATE KIT REQUIRED.
REFER TO PAGES 271 TO 273 FOR DETAILS.

Note: For units smaller than 15kVA, please refer to the three phase encapsulated units in Section 8.

Products listed on this page are available as 'CE Mark' products. Please consult our sales office.

FOR TERMINATION DETAILS SEE PAGE 275.

FOR ACCESSORIES SEE PAGES 271 TO 274.



SECTION 7



ALUMINUM WOUND, THREE PHASE

240 Delta Primary Volts

480Y/277 Secondary Volts

60 Hz

kVA	Catalog Number	Case Style (Pages 260 - 267)	Approx. Dimensions (Inches)			Approx. Weight (Lbs.)	Mtg Type W - Wall F - Floor	Wiring Diagram (Pages 276 - 288)
			Width	Depth	Height			
15	NMK015DK	NH5	19.40	20.20	21.50	200	F or W *	SCD 40
30	NMK030DK	NH6	23.90	25.00	28.75	280	F or W *	SCD 26
45	NMK045DK	NH6	23.90	25.00	28.75	375	F or W *	SCD 26
75	NMK075DK	NH3	26.00	25.00	38.00	540	F or W *	SCD 26
112.5	NMK112DK	NH3	26.00	25.00	38.00	775	F or W *	SCD 26
150	NMK150DK	NH4	32.00	29.50	41.00	850	F	SCD 26
225	NMK225DK	NH4	32.00	29.50	41.00	1400	F	SCD 26
300	NMK300DK	NJ1	39.50	34.00	51.50	1700	F	SCD 26
500	NMK500DK	NJ2	48.50	38.40	59.00	2700	F	NO TAPS
750	NMK750DK	NJ3	51.50	43.40	66.00	3250	F	NO TAPS

For shielded units, please add the suffix "S" to the above part numbers.

*WALL MOUNTING KIT AND/OR DRIP PLATE KIT REQUIRED.
REFER TO PAGES 271 TO 273 FOR DETAILS.

480 Delta Primary Volts

208Y/120 Secondary Volts

60 Hz

May be used on a 4 wire 480Y/277 Volt Supply

kVA	Catalog Number	Case Style (Pages 260 - 267)	Approx. Dimensions (Inches)			Approx. Weight (Lbs.)	Mtg Type W - Wall F - Floor	Wiring Diagram (Pages 276 - 288)
			Width	Depth	Height			
15	NMK015KB	NH5	19.40	20.20	21.50	200	F or W *	SCD 7
30	NMK030KB	NH6	23.90	25.00	28.75	280	F or W *	SCD 19
45	NMK045KB	NH6	23.90	25.00	28.75	375	F or W *	SCD 19
75	NMK075KB	NH3	26.00	25.00	38.00	540	F or W *	SCD 19
112.5	NMK112KB	NH3	26.00	25.00	38.00	775	F or W *	SCD 19
150	NMK150KB	NH4	32.00	29.50	41.00	850	F	SCD 19
225	NMK225KB	NH4	32.00	29.50	41.00	1400	F	SCD 19
300	NMK300KB	NJ1	39.50	34.00	51.50	1700	F	SCD 19
500	NMK500KB	NJ2	48.50	38.40	59.00	2150	F	SCD 20
750	NMK750KB	NJ3	51.50	43.40	66.00	3200	F	SCD 20

For shielded units, please add the suffix "S" to the above part numbers.

*WALL MOUNTING KIT AND/OR DRIP PLATE KIT REQUIRED.
REFER TO PAGES 271 TO 273 FOR DETAILS.

480 Delta Primary Volts

240 Delta/120 CT Secondary Volts

60 Hz

May be used on a 4 wire 480Y/277 Volt Supply

kVA	Catalog Number	Case Style (Pages 260 - 267)	Approx. Dimensions (Inches)			Approx. Weight (Lbs.)	Mtg Type W - Wall F - Floor	Wiring Diagram (Pages 276 - 288)
			Width	Depth	Height			
15	NMK015KD	NH5	19.40	20.20	21.50	200	F or W *	SCD 13
30	NMK030KD	NH6	23.90	25.00	28.75	280	F or W *	SCD 21
45	NMK045KD	NH6	23.90	25.00	28.75	375	F or W *	SCD 21
75	NMK075KD	NH3	26.00	25.00	38.00	540	F or W *	SCD 21
112.5	NMK112KD	NH3	26.00	25.00	38.00	775	F or W *	SCD 21
150	NMK150KD	NH4	32.00	29.50	41.00	850	F	SCD 21
225	NMK225KD	NH4	32.00	29.50	41.00	1400	F	SCD 21
300	NMK300KD	NJ1	39.50	34.00	51.50	1700	F	SCD 21
500	NMK500KD	NJ2	48.50	38.40	59.00	2700	F	SCD 22
750	NMK750KD	NJ3	51.50	43.40	66.00	3250	F	SCD 22

For shielded units, please add the suffix "S" to the above part numbers.

*WALL MOUNTING KIT AND/OR DRIP PLATE KIT REQUIRED.
REFER TO PAGES 271 TO 273 FOR DETAILS.

Note: For units smaller than 15kVA, please refer to the three phase encapsulated units in Section 8.

Products listed on this page are available as 'CE Mark' products. Please consult our sales office.



FOR TERMINATION DETAILS SEE PAGE 275.

FOR ACCESSORIES SEE PAGES 271 TO 274.



ALUMINUM WOUND, THREE PHASE



480 Delta Primary Volts

480Y/277 Secondary Volts

60 Hz

May be used on a 4 wire 480Y/277 Volt Supply

kVA	Catalog Number	Case Style (Pages 260 - 267)	Approx. Dimensions (Inches)			Approx. Weight (Lbs.)	Mtg Type W - Wall F - Floor	Wiring Diagram (Pages 276 - 288)
			Width	Depth	Height			
15	NMK015KK	NH5	19.40	20.20	21.50	200	F or W *	SCD 25
30	NMK030KK	NH6	23.90	25.00	28.75	280	F or W *	SCD 19
45	NMK045KK	NH6	23.90	25.00	28.75	375	F or W *	SCD 19
75	NMK075KK	NH3	26.00	25.00	38.00	540	F or W *	SCD 19
112.5	NMK112KK	NH3	26.00	25.00	38.00	775	F or W *	SCD 19
150	NMK150KK	NH4	32.00	29.50	41.00	850	F	SCD 19
225	NMK225KK	NH4	32.00	29.50	41.00	1400	F	SCD 19
300	NMK300KK	NJ1	39.50	34.00	51.50	1700	F	SCD 19
500	NMK500KK	NJ2	48.50	38.40	59.00	2700	F	SCD 20
750	NMK750KK	NJ3	51.50	43.40	66.00	3250	F	SCD 20

For shielded units, please add the suffix "S" to the above part numbers.

*WALL MOUNTING KIT AND/OR DRIP PLATE KIT REQUIRED. REFER TO PAGES 271 TO 273 FOR DETAILS.

600 Delta Primary Volts

208Y/120 Secondary Volts

60 Hz

May be used on a 4 wire 600Y/347 Volt Supply

kVA	Catalog Number	Case Style (Pages 260 - 267)	Approx. Dimensions (Inches)			Approx. Weight (Lbs.)	Mtg Type W - Wall F - Floor	Wiring Diagram (Pages 276 - 288)
			Width	Depth	Height			
15	NMK015PB	NH5	19.40	20.20	21.50	200	F or W *	SCD 9
30	NMK030PB	NH6	23.90	25.00	28.75	280	F or W *	SCD 9
45	NMK045PB	NH6	23.90	25.00	28.75	375	F or W *	SCD 9
75	NMK075PB	NH3	26.00	25.00	38.00	540	F or W *	SCD 9
112.5	NMK112PB	NH3	26.00	25.00	38.00	775	F or W *	SCD 9
150	NMK150PB	NH4	32.00	29.50	41.00	850	F	SCD 9
225	NMK225PB	NH4	32.00	29.50	41.00	1400	F	SCD 9
300	NMK300PB	NJ1	39.50	34.00	51.50	1700	F	SCD 9
500	NMK500PB	NJ2	48.50	38.40	59.00	2200	F	SCD 10
750	NMK750PB	NJ3	51.50	43.40	66.00	3250	F	SCD 10

For shielded units, please add the suffix "S" to the above part numbers.

*WALL MOUNTING KIT AND/OR DRIP PLATE KIT REQUIRED. REFER TO PAGES 271 TO 273 FOR DETAILS.

600Y Primary Volts

240 Delta Secondary Volts

60 Hz

Do not connect neutral when used on 600Y/347 Volt Supply

kVA	Catalog Number	Case Style (Pages 260 - 267)	Approx. Dimensions (Inches)			Approx. Weight (Lbs.)	Mtg Type W - Wall F - Floor	Wiring Diagram (Pages 276 - 288)
			Width	Depth	Height			
15	NMK015PD	NH5	19.40	20.20	21.50	200	F or W *	SCD 16
30	NMK030PD	NH6	23.90	25.00	28.75	280	F or W *	SCD 16
45	NMK045PD	NH6	23.90	25.00	28.75	375	F or W *	SCD 16
75	NMK075PD	NH3	26.00	25.00	38.00	540	F or W *	SCD 16
112.5	NMK112PD	NH3	26.00	25.00	38.00	775	F or W *	SCD 16
150	NMK150PD	NH4	32.00	29.50	41.00	850	F	SCD 16
225	NMK225PD	NH4	32.00	29.50	41.00	1400	F	SCD 16
300	NMK300PD	NJ1	39.50	34.00	51.50	1700	F	SCD 16
500	NMK500PD	NJ2	48.50	38.40	59.00	2700	F	SCD 29
750	NMK750PD	NJ3	51.50	43.40	66.00	3250	F	SCD 29

For shielded units, please add the suffix "S" to the above part numbers.

*WALL MOUNTING KIT AND/OR DRIP PLATE KIT REQUIRED. REFER TO PAGES 271 TO 273 FOR DETAILS.

Note: For units smaller than 15kVA, please refer to the three phase encapsulated units in Section 8.

Products listed on this page are available as 'CE Mark' products. Please consult our sales office.

FOR TERMINATION DETAILS SEE PAGE 275.

FOR ACCESSORIES SEE PAGES 271 TO 274.

Data subject to change without notice.



SECTION 7

ALUMINUM WOUND, THREE PHASE



600 Delta Primary Volts

480Y/277 Secondary Volts

60 Hz

May be used on a 4 wire 600Y/347 Volt Supply

kVA	Catalog Number	Case Style (Pages 260 - 267)	Approx. Dimensions (Inches)			Approx. Weight (Lbs.)	Mtg Type W - Wall F - Floor	Wiring Diagram (Pages 276 - 288)
			Width	Depth	Height			
15	NMK015PK	NH5	19.40	20.20	21.50	200	F or W *	SCD 9
30	NMK030PK	NH6	23.90	25.00	28.75	280	F or W *	SCD 9
45	NMK045PK	NH6	23.90	25.00	28.75	375	F or W *	SCD 9
75	NMK075PK	NH3	26.00	25.00	38.00	540	F or W *	SCD 9
112.5	NMK112PK	NH3	26.00	25.00	38.00	775	F or W *	SCD 9
150	NMK150PK	NH4	32.00	29.50	41.00	850	F	SCD 9
225	NMK225PK	NH4	32.00	29.50	41.00	1400	F	SCD 9
300	NMK300PK	NJ1	39.50	34.00	51.50	1700	F	SCD 9
500	NMK500PK	NJ2	48.50	38.40	59.00	2700	F	SCD 10
750	NMK750PK	NJ3	51.50	43.40	66.00	3250	F	SCD 10

For shielded units, please add the suffix "S" to the above part numbers.

*WALL MOUNTING KIT AND/OR DRIP PLATE KIT REQUIRED.
REFER TO PAGES 271 TO 273 FOR DETAILS.

Note: For units smaller than 15kVA, please refer to the three phase encapsulated units in Section 8.

Products listed on this page are available as 'CE Mark' products. Please consult our sales office.

FOR TERMINATION DETAILS SEE PAGE 275.

FOR ACCESSORIES SEE PAGES 271 TO 274.

Data subject to change without notice.



COPPER WOUND, THREE PHASE



208 Delta Primary Volts

208Y/120 Secondary Volts

60 Hz

kVA	Catalog Number	Case Style (Pages 260 - 267)	Approx. Dimensions (Inches)			Approx. Weight (Lbs.)	Mtg Type W - Wall F - Floor	Wiring Diagram (Pages 276 - 288)
			Width	Depth	Height			
15	NMK015BBCN	NH5	19.40	20.20	21.50	200	F or W *	SCD 7
30	NMK030BBC	NH6	23.90	25.00	28.75	300	F or W *	SCD 9
45	NMK045BBC	NH6	23.90	25.00	28.75	400	F or W *	SCD 9
75	NMK075BBC	NH3	26.00	25.00	38.00	600	F or W *	SCD 9
112.5	NMK112BBC	NH3	26.00	25.00	38.00	850	F	SCD 9
150	NMK150BBC	NH4	32.00	29.50	41.00	975	F	SCD 9
225	NMK225BBC	NH4	32.00	29.50	41.00	1500	F	SCD 9
300	NMK300BBC	NJ1	39.50	34.00	51.50	1850	F	SCD 9
500	NMK500BBC	NJ2	48.50	38.40	59.00	2800	F	SCD 25
750	NMK750BBC	NJ3	51.50	43.40	66.00	3550	F	SCD 25

For shielded units, please replace the suffix "C" with "K" on the above part numbers.

*WALL MOUNTING KIT AND/OR DRIP PLATE KIT REQUIRED. REFER TO PAGES 271 TO 273 FOR DETAILS.

208 Delta Primary Volts

480Y/277 Secondary Volts

60 Hz

kVA	Catalog Number	Case Style (Pages 260 - 267)	Approx. Dimensions (Inches)			Approx. Weight (Lbs.)	Mtg Type W - Wall F - Floor	Wiring Diagram (Pages 276 - 288)
			Width	Depth	Height			
15	NMK015BKCN	NH5	19.40	20.20	21.50	200	F or W *	SCD 40
30	NMK030BKC	NH6	23.90	25.00	28.75	300	F or W *	SCD 26
45	NMK045BKC	NH6	23.90	25.00	28.75	400	F or W *	SCD 26
75	NMK075BKC	NH3	26.00	25.00	38.00	600	F or W *	SCD 26
112.5	NMK112BKC	NH3	26.00	25.00	38.00	850	F	SCD 26
150	NMK150BKC	NH4	32.00	29.50	41.00	975	F	SCD 26
225	NMK225BKC	NH4	32.00	29.50	41.00	1500	F	SCD 26
300	NMK300BKC	NJ1	39.50	34.00	51.50	1850	F	SCD 26
500	NMK500BKC	NJ2	48.50	38.40	59.00	2800	F	SCD 23
750	NMK750BKC	NJ3	51.50	43.40	66.00	3550	F	SCD 23

For shielded units, please replace the suffix "C" with "K" on the above part numbers.

*WALL MOUNTING KIT AND/OR DRIP PLATE KIT REQUIRED. REFER TO PAGES 271 TO 273 FOR DETAILS.

240 Delta Primary Volts

208Y/120 Secondary Volts

60 Hz

kVA	Catalog Number	Case Style (Pages 260 - 267)	Approx. Dimensions (Inches)			Approx. Weight (Lbs.)	Mtg Type W - Wall F - Floor	Wiring Diagram (Pages 276 - 288)
			Width	Depth	Height			
15	NMK015DBCN	NH5	19.40	20.20	21.50	200	F or W *	SCD 40
30	NMK030DBC	NH6	23.90	25.00	28.75	300	F or W *	SCD 9
45	NMK045DBC	NH6	23.90	25.00	28.75	400	F or W *	SCD 9
75	NMK075DBC	NH3	26.00	25.00	38.00	600	F or W *	SCD 9
112.5	NMK112DBC	NH3	26.00	25.00	38.00	850	F	SCD 9
150	NMK150DBC	NH4	32.00	29.50	41.00	975	F	SCD 9
225	NMK225DBC	NH4	32.00	29.50	41.00	1500	F	SCD 9
300	NMK300DBC	NJ1	39.50	34.00	51.50	1850	F	SCD 9
500	NMK500DBC	NJ2	48.50	38.40	59.00	2800	F	NO TAPS
750	NMK750DBC	NJ3	51.50	43.40	66.00	3550	F	NO TAPS

For shielded units, please replace the suffix "C" with "K" on the above part numbers.

*WALL MOUNTING KIT AND/OR DRIP PLATE KIT REQUIRED. REFER TO PAGES 271 TO 273 FOR DETAILS.

Note: For units smaller than 15kVA, please refer to the three phase encapsulated units in Section 8.

Products listed on this page are available as 'CE Mark' products. Please consult our sales office.

FOR TERMINATION DETAILS SEE PAGE 275.

FOR ACCESSORIES SEE PAGES 271 TO 274.

Data subject to change without notice.



SECTION 7

COPPER WOUND, THREE PHASE



240 Delta Primary Volts

480Y/277 Secondary Volts

60 Hz

kVA	Catalog Number	Case Style (Pages 260 - 267)	Approx. Dimensions (Inches)			Approx. Weight (Lbs.)	Mtg Type W - Wall F - Floor	Wiring Diagram (Pages 276 - 288)
			Width	Depth	Height			
15	NMK015DKCN	NH5	19.40	20.20	21.50	200	F or W *	SCD 40
30	NMK030DKC	NH6	23.90	25.00	28.75	300	F or W *	SCD 26
45	NMK045DKC	NH6	23.90	25.00	28.75	400	F or W *	SCD 26
75	NMK075DKC	NH3	26.00	25.00	38.00	600	F or W *	SCD 26
112.5	NMK112DKC	NH3	26.00	25.00	38.00	850	F	SCD 26
150	NMK150DKC	NH4	32.00	29.50	41.00	975	F	SCD 26
225	NMK225DKC	NH4	32.00	29.50	41.00	1500	F	SCD 26
300	NMK300DKC	NJ1	39.50	34.00	51.50	1850	F	SCD 26
500	NMK500DKC	NJ2	48.50	38.40	59.00	2800	F	NO TAPS
750	NMK750DKC	NJ3	51.50	43.40	66.00	3550	F	NO TAPS

For shielded units, please replace the suffix "C" with "K" on the above part numbers.

*WALL MOUNTING KIT AND/OR DRIP PLATE KIT REQUIRED.
REFER TO PAGES 271 TO 273 FOR DETAILS.

480 Delta Primary Volts

208Y/120 Secondary Volts

60 Hz

May be used on a 4 wire 480Y/277 Volt Supply

kVA	Catalog Number	Case Style (Pages 260 - 267)	Approx. Dimensions (Inches)			Approx. Weight (Lbs.)	Mtg Type W - Wall F - Floor	Wiring Diagram (Pages 276 - 288)
			Width	Depth	Height			
15	NMK015KBCN	NH5	19.40	20.20	21.50	200	F or W *	SCD 7
30	NMK030KBCN	NH6	23.90	25.00	28.75	300	F or W *	SCD 19
45	NMK045KBC	NH6	23.90	25.00	28.75	400	F or W *	SCD 19
75	NMK075KBC	NH3	26.00	25.00	38.00	600	F or W *	SCD 19
112.5	NMK112KBC	NH3	26.00	25.00	38.00	850	F	SCD 19
150	NMK150KBC	NH4	32.00	29.50	41.00	975	F	SCD 19
225	NMK225KBC	NH4	32.00	29.50	41.00	1500	F	SCD 19
300	NMK300KBC	NJ1	39.50	34.00	51.50	1850	F	SCD 19
500	NMK500KBC	NJ2	48.50	38.40	59.00	2500	F	SCD 19
750	NMK750KBC	NJ3	51.50	43.40	66.00	3300	F	SCD 19

For shielded units, please replace the suffix "C" with "K" on the above part numbers.

*WALL MOUNTING KIT AND/OR DRIP PLATE KIT REQUIRED.
REFER TO PAGES 271 TO 273 FOR DETAILS.

480 Delta Primary Volts

240 Delta/120 CT Secondary Volts

60 Hz

May be used on a 4 wire 480Y/277 Volt Supply

kVA	Catalog Number	Case Style (Pages 260 - 267)	Approx. Dimensions (Inches)			Approx. Weight (Lbs.)	Mtg Type W - Wall F - Floor	Wiring Diagram (Pages 276 - 288)
			Width	Depth	Height			
15	NMK015KDCN	NH5	19.40	20.20	21.50	200	F or W *	SCD 13
30	NMK030KDCN	NH6	23.90	25.00	28.75	300	F or W *	SCD 21
45	NMK045KDC	NH6	23.90	25.00	28.75	400	F or W *	SCD 21
75	NMK075KDC	NH3	26.00	25.00	38.00	600	F or W *	SCD 21
112.5	NMK112KDC	NH3	26.00	25.00	38.00	850	F	SCD 21
150	NMK150KDC	NH4	32.00	29.50	41.00	975	F	SCD 21
225	NMK225KDC	NH4	32.00	29.50	41.00	1500	F	SCD 21
300	NMK300KDC	NJ1	39.50	34.00	51.50	1850	F	SCD 21
500	NMK500KDC	NJ2	48.50	38.40	59.00	2800	F	SCD 22
750	NMK750KDC	NJ3	51.50	43.40	66.00	3550	F	SCD 22

For shielded units, please replace the suffix "C" with "K" on the above part numbers.

*WALL MOUNTING KIT AND/OR DRIP PLATE KIT REQUIRED.
REFER TO PAGES 271 TO 273 FOR DETAILS.

Note: For units smaller than 15kVA, please refer to the three phase encapsulated units in Section 8.

Products listed on this page are available as 'CE Mark' products. Please consult our sales office.

FOR TERMINATION DETAILS SEE PAGE 275.

FOR ACCESSORIES SEE PAGES 271 TO 274.

Data subject to change without notice.



COPPER WOUND, THREE PHASE



480 Delta Primary Volts

480Y/277 Secondary Volts

60 Hz

May be used on a 4 wire 480Y/277 Volt Supply

kVA	Catalog Number	Case Style (Pages 260 - 267)	Approx. Dimensions (Inches)			Approx. Weight (Lbs.)	Mtg Type W - Wall F - Floor	Wiring Diagram (Pages 276 - 288)
			Width	Depth	Height			
15	NMK015KCCN	NH5	19.40	20.20	21.50	200	F or W *	SCD 25
30	NMK030KCCN	NH6	23.90	25.00	28.75	300	F or W *	SCD 19
45	NMK045KCCN	NH6	23.90	25.00	28.75	400	F or W *	SCD 19
75	NMK075KCCN	NH3	26.00	25.00	38.00	600	F or W *	SCD 19
112.5	NMK112KCCN	NH3	26.00	25.00	38.00	850	F	SCD 19
150	NMK150KCCN	NH4	32.00	29.50	41.00	975	F	SCD 19
225	NMK225KCCN	NH4	32.00	29.50	41.00	1500	F	SCD 19
300	NMK300KCCN	NJ1	39.50	34.00	51.50	1850	F	SCD 19
500	NMK500KCCN	NJ2	48.50	38.40	59.00	2800	F	SCD 20
750	NMK750KCCN	NJ3	51.50	43.40	66.00	3550	F	SCD 20

For shielded units, please replace the suffix "C" with "K" on the above part numbers.

*WALL MOUNTING KIT AND/OR DRIP PLATE KIT REQUIRED. REFER TO PAGES 271 TO 273 FOR DETAILS.

600 Delta Primary Volts

208Y/120 Secondary Volts

60 Hz

May be used on a 4 wire 600Y/347 Volt Supply

kVA	Catalog Number	Case Style (Pages 260 - 267)	Approx. Dimensions (Inches)			Approx. Weight (Lbs.)	Mtg Type W - Wall F - Floor	Wiring Diagram (Pages 276 - 288)
			Width	Depth	Height			
15	NMK015PBCN	NH5	19.40	20.20	21.50	200	F or W *	SCD 9
30	NMK030PBCN	NH6	23.90	25.00	28.75	300	F or W *	SCD 9
45	NMK045PBCN	NH6	23.90	25.00	28.75	400	F or W *	SCD 9
75	NMK075PBCN	NH3	26.00	25.00	38.00	600	F or W *	SCD 9
112.5	NMK112PBCN	NH3	26.00	25.00	38.00	850	F	SCD 9
150	NMK150PBCN	NH4	32.00	29.50	41.00	975	F	SCD 9
225	NMK225PBCN	NH4	32.00	29.50	41.00	1500	F	SCD 9
300	NMK300PBCN	NJ1	39.50	34.00	51.50	1850	F	SCD 9
500	NMK500PBCN	NJ2	48.50	38.40	59.00	2500	F	SCD 10
750	NMK750PBCN	NJ3	51.50	43.40	66.00	3550	F	SCD 10

For shielded units, please replace the suffix "C" with "K" on the above part numbers.

*WALL MOUNTING KIT AND/OR DRIP PLATE KIT REQUIRED. REFER TO PAGES 271 TO 273 FOR DETAILS.

600Y Primary Volts

240 Delta Secondary Volts

60 Hz

Do not connect neutral when used on 600Y/347 Volt Supply

kVA	Catalog Number	Case Style (Pages 260 - 267)	Approx. Dimensions (Inches)			Approx. Weight (Lbs.)	Mtg Type W - Wall F - Floor	Wiring Diagram (Pages 276 - 288)
			Width	Depth	Height			
15	NMK015PDCN	NH5	19.40	20.20	21.50	200	F or W *	SCD 16
30	NMK030PDCN	NH6	23.90	25.00	28.75	300	F or W *	SCD 16
45	NMK045PDCN	NH6	23.90	25.00	28.75	400	F or W *	SCD 16
75	NMK075PDCN	NH3	26.00	25.00	38.00	600	F or W *	SCD 16
112.5	NMK112PDCN	NH3	26.00	25.00	38.00	850	F	SCD 16
150	NMK150PDCN	NH4	32.00	29.50	41.00	975	F	SCD 16
225	NMK225PDCN	NH4	32.00	29.50	41.00	1500	F	SCD 16
300	NMK300PDCN	NJ1	39.50	34.00	51.50	1850	F	SCD 16
500	NMK500PDCN	NJ2	48.50	38.40	59.00	2800	F	SCD 29
750	NMK750PDCN	NJ3	51.50	43.40	66.00	3550	F	SCD 29

For shielded units, please replace the suffix "C" with "K" on the above part numbers.

*WALL MOUNTING KIT AND/OR DRIP PLATE KIT REQUIRED. REFER TO PAGES 271 TO 273 FOR DETAILS.

Note: For units smaller than 15kVA, please refer to the three phase encapsulated units in Section 8.

Products listed on this page are available as 'CE Mark' products. Please consult our sales office.

FOR TERMINATION DETAILS SEE PAGE 275.

FOR ACCESSORIES SEE PAGES 271 TO 274.

Data subject to change without notice.



SECTION 7

COPPER WOUND, THREE PHASE



600 Delta Primary Volts

480Y/277 Secondary Volts

60 Hz

May be used on a 4 wire 600Y/347 Volt Supply

kVA	Catalog Number	Case Style (Pages 260 - 267)	Approx. Dimensions (Inches)			Approx. Weight (Lbs.)	Mtg Type W - Wall F - Floor	Wiring Diagram (Pages 276 - 288)
			Width	Depth	Height			
15	NMK015PKCN	NH5	19.40	20.20	21.50	200	F or W *	SCD 9
30	NMK030PKCN	NH6	23.90	25.00	28.75	300	F or W *	SCD 9
45	NMK045PKC	NH6	23.90	25.00	28.75	400	F or W *	SCD 9
75	NMK075PKC	NH3	26.00	25.00	38.00	600	F or W *	SCD 9
112.5	NMK112PKC	NH3	26.00	25.00	38.00	850	F	SCD 9
150	NMK150PKC	NH4	32.00	29.50	41.00	975	F	SCD 9
225	NMK225PKC	NH4	32.00	29.50	41.00	1500	F	SCD 9
300	NMK300PKC	NJ1	39.50	34.00	51.50	1850	F	SCD 9
500	NMK500PKC	NJ2	48.50	38.40	59.00	2800	F	SCD 10
750	NMK750PKC	NJ3	51.50	43.40	66.00	3550	F	SCD 10

For shielded units, please replace the suffix "C" with "K" on the above part numbers.

*WALL MOUNTING KIT AND/OR DRIP PLATE KIT REQUIRED.
REFER TO PAGES 271 TO 273 FOR DETAILS.

Note: For units smaller than 15kVA, please refer to the three phase encapsulated units in Section 8.

Products listed on this page are available as 'CE Mark' products. Please consult our sales office.

FOR TERMINATION DETAILS SEE PAGE 275.

FOR ACCESSORIES SEE PAGES 271 TO 274.

Data subject to change without notice.





HPS SUPERSENTINEL®

600 VOLT CLASS ENERGY EFFICIENT GENERAL PURPOSE DISTRIBUTION TRANSFORMERS

General Purpose Distribution Transformer Efficiencies:

Energy efficient general purpose transformers are designed for linear loads and are most frequently used for applications such as commercial buildings which will supply and variety of general loads.

HPS SUPERSENTINEL (PART NUMBER PREFIX SMK OR SMF)

- Exceeds DOE 10 CFR Part 431 and (if applicable) C802.2 efficiencies at 35% of rated load.
- Efficiency performance will meet NEMA Premium® guidelines; 30% lower losses than DOE 10 CFR Part 431 and (if applicable) CSA C802.2 efficiency standards; when measured under a linear load profile.
- Copper and Aluminum Available.



HPS SUPERSENTINEL® 600 VOLT CLASS SUPER ENERGY EFFICIENT GENERAL PURPOSE DISTRIBUTION TRANSFORMER



ALUMINUM & COPPER, SINGLE PHASE STANDARD SPECIFICATIONS



15 to 37.5 kVA



50 to 167 kVA



	15 to 37.5 kVA	50 to 167 kVA
Efficiency	Exceeds DOE 10 CFR Part 431 and C802.2 efficiencies at 35% of the rated load. Efficiency performance will meet the NEMA Premium® guidelines; 30% lower losses than DOE 10 CFR Part 431 and (if applicable) C802.2 efficiency standards; when measured under a linear load profile.	
UL Listed	File: E112313	File: E112313
CSA Certified	File: LR3902	File: LR3902
Frequency	60 Hz	60 Hz
Insulation System	220°C (150°C rise) (optional 115°C and 80°C rise available)	220°C (150°C rise) (optional 115°C and 80°C rise available)
Enclosure Type	Heavy Duty Ventilated Type 3R Optional Type 4, 4X (stainless steel) and 12.	Heavy Duty Ventilated Type 3R Optional Type 4, 4X (stainless steel) and 12.
Enclosure Finish	ANSI 61 Grey, UL50	ANSI 61 Grey, UL50
Standard Primary Taps	Refer to wiring diagrams for details.	Refer to wiring diagrams for details.
Termination	Front accessible separate high and low voltage terminals; connectors suitable for aluminum and copper are provided for easy cable installation.	Front accessible separate high and low voltage terminals; connectors suitable for aluminum and copper are provided for easy cable installation.
Conduit Knock-Outs	Standard on all units.	Standard on 50 kVA, 75 kVA & 100 kVA units.
Impedance	Typically 2.5% to 6.5%	Typically 2.5% to 6.5%
Mounting	Floor or wall/ceiling mounting available. Refer to selection tables for details.	Floor or wall/ceiling mounting available. Refer to selection tables for details.
Seismic	Meets Occupancy Category III Ip=1.25 for Ss=1.0g per IBC 2006; section 1613, earthquake loads and NBCC 2005 for ground level installations only for all locations in North America.	Meets Occupancy Category III Ip=1.25 for Ss=1.0g per IBC 2006; section 1613, earthquake loads and NBCC 2005 for ground level installations only for all locations in North America.
Sound level	Meets NEMA ST-20 standards. (Optional low noise units available)	Meets NEMA ST-20 standards. (Optional low noise units available)

Other voltages and kVA sizes not listed in this section are available upon request for both aluminum and copper wound units. Features as listed above may differ. Please contact customer service for details, price and availability.



FOR TERMINATION DETAILS SEE PAGE 275.

FOR ACCESSORIES SEE PAGES 271 TO 274.



ALUMINUM WOUND, SINGLE PHASE



208 Primary Volts

120/240 Secondary Volts

60 Hz

kVA	Catalog Number	Case Style (Pages 260 - 267)	Approx. Dimensions (Inches)			Approx. Weight (Lbs.)	Mtg Type W - Wall F - Floor	Wiring Diagram (Pages 276 - 288)
			Width	Depth	Height			
15	SMF015BE	NH5	19.40	20.20	21.50	170	F or W *	SCD 32
25	SMF025BE	NH6	23.90	25.00	28.75	220	F or W *	SCD 31
37.5	SMF037BE	NH6	23.90	25.00	28.75	260	F or W *	SCD 31
50	SMF050BE	NH3	26.00	25.00	38.00	375	F or W *	SCD 2
75	SMF075BE	NH3	26.00	25.00	38.00	500	F or W *	SCD 31
100	SMF100BE	NH4	32.00	29.50	41.00	650	F	SCD 39
150	SMF150BE	NJ4	32.00	32.50	50.00	850	F	SCD 39
167	SMF167BE	NJ4	32.00	32.50	50.00	950	F	SCD 39

For shielded units, please add the suffix "S" to the above part numbers.

*WALL MOUNTING KIT AND/OR DRIP PLATE KIT REQUIRED. REFER TO PAGES 271 TO 273 FOR DETAILS.

240 X 480 Primary Volts

120/240 Secondary Volts

60 Hz

kVA	Catalog Number	Case Style (Pages 260 - 267)	Approx. Dimensions (Inches)			Approx. Weight (Lbs.)	Mtg Type W - Wall F - Floor	Wiring Diagram (Pages 276 - 288)
			Width	Depth	Height			
15	SMF015LE	NH5	19.40	20.20	21.50	170	F or W *	SCD 34
25	SMF025LE	NH6	23.90	25.00	28.75	220	F or W *	SCD 17
37.5	SMF037LE	NH6	23.90	25.00	28.75	260	F or W *	SCD 17
50	SMF050LE	NH3	26.00	25.00	38.00	370	F or W *	SCD 17
75	SMF075LE	NH3	26.00	25.00	38.00	500	F or W *	SCD 17
100	SMF100LE	NH4	32.00	29.50	41.00	650	F	SCD 17
150	SMF150LE	NJ4	32.00	32.50	50.00	850	F	SCD 17
167	SMF167LE	NJ4	32.00	32.50	50.00	900	F	SCD 17

For shielded units, please add the suffix "S" to the above part numbers.

*WALL MOUNTING KIT AND/OR DRIP PLATE KIT REQUIRED. REFER TO PAGES 271 TO 273 FOR DETAILS.

277 Primary Volts

120/240 Secondary Volts

60 Hz

kVA	Catalog Number	Case Style (Pages 260 - 267)	Approx. Dimensions (Inches)			Approx. Weight (Lbs.)	Mtg Type W - Wall F - Floor	Wiring Diagram (Pages 276 - 288)
			Width	Depth	Height			
15	SMF015FE	NH5	19.40	20.20	21.50	170	F or W *	SCD 32
25	SMF025FE	NH6	23.90	25.00	28.75	260	F or W *	SCD 31
37.5	SMF037FE	NH6	23.90	25.00	28.75	400	F or W *	SCD 31
50	SMF050FE	NH3	26.00	25.00	38.00	450	F or W *	SCD 31
75	SMF075FE	NH3	26.00	25.00	38.00	650	F or W *	SCD 31
100	SMF100FE	NH4	32.00	29.50	41.00	700	F	SCD 39
150	SMF150FE	NJ4	32.00	32.50	50.00	830	F	SCD 39
167	SMF167FE	NJ4	32.00	32.50	50.00	880	F	SCD 39

For shielded units, please add the suffix "S" to the above part numbers.

*WALL MOUNTING KIT AND/OR DRIP PLATE KIT REQUIRED. REFER TO PAGES 271 TO 273 FOR DETAILS.

Products listed on this page are available as 'CE Mark' products. Please consult our sales office.

FOR TERMINATION DETAILS SEE PAGE 275.

FOR ACCESSORIES SEE PAGES 271 TO 274.



SECTION 7

ALUMINUM WOUND, SINGLE PHASE



416 Primary Volts

120/240 Secondary Volts

60 Hz

kVA	Catalog Number	Case Style (Pages 260 - 267)	Approx. Dimensions (Inches)			Approx. Weight (Lbs.)	Mtg Type W - Wall F - Floor	Wiring Diagram (Pages 276 - 288)
			Width	Depth	Height			
15	SMF015HE	NH5	19.40	20.20	21.50	220	F or W *	SCD 32
25	SMF025HE	NH6	23.90	25.00	28.75	220	F or W *	SCD 31
37.5	SMF037HE	NH6	23.90	25.00	28.75	260	F or W *	SCD 31
50	SMF050HE	NH3	26.00	25.00	38.00	400	F or W *	SCD 31
75	SMF075HE	NH3	26.00	25.00	38.00	480	F or W *	SCD 31
100	SMF100HE	NH4	32.00	29.50	41.00	650	F	SCD 39
150	SMF150HE	NJ4	32.00	32.50	50.00	850	F	SCD 39
167	SMF167HE	NJ4	32.00	32.50	50.00	900	F	SCD 39

For shielded units, please add the suffix "S" to the above part numbers.

*WALL MOUNTING KIT AND/OR DRIP PLATE KIT REQUIRED.
REFER TO PAGES 271 TO 273 FOR DETAILS.

600 Primary Volts

120/240 Secondary Volts

60 Hz

kVA	Catalog Number	Case Style (Pages 260 - 267)	Approx. Dimensions (Inches)			Approx. Weight (Lbs.)	Mtg Type W - Wall F - Floor	Wiring Diagram (Pages 276 - 288)
			Width	Depth	Height			
15	SMF015PE	NH5	19.40	20.20	21.50	220	F or W *	SCD 32
25	SMF025PE	NH6	23.90	25.00	28.75	220	F or W *	SCD 31
37.5	SMF037PE	NH6	23.90	25.00	28.75	260	F or W *	SCD 31
50	SMF050PE	NH3	26.00	25.00	38.00	400	F or W *	SCD 31
75	SMF075PE	NH3	26.00	25.00	38.00	480	F or W *	SCD 31
100	SMF100PE	NH4	32.00	29.50	41.00	650	F	SCD 39
150	SMF150PE	NJ4	32.00	32.50	50.00	850	F	SCD 39
167	SMF167PE	NJ4	32.00	32.50	50.00	900	F	SCD 39

For shielded units, please add the suffix "S" to the above part numbers.

*WALL MOUNTING KIT AND/OR DRIP PLATE KIT REQUIRED.
REFER TO PAGES 271 TO 273 FOR DETAILS.

SINGLE PHASE, EXPORT MODEL

190/200/208/220 X 380/400/416/440 Primary Volts

120/240 Secondary Volts

50/60 Hz**

kVA	Catalog Number	Case Style (Pages 260 - 267)	Approx. Dimensions (Inches)			Approx. Weight (Lbs.)	Mtg Type W - Wall F - Floor	Wiring Diagram (Pages 276 - 288)
			Width	Depth	Height			
15	SMF015XE	NH6	23.90	25.00	28.75	190	F or W *	SCD 30
25	SMF025XE	NH6	23.90	25.00	28.75	240	F or W *	SCD 30
37.5	SMF037XE	NH6	23.90	25.00	28.75	300	F or W *	SCD 30
50	SMF050XE	NH3	26.00	25.00	38.00	390	F or W *	SCD 30
75	SMF075XE	NH3	26.00	25.00	38.00	540	F or W *	SCD 30
100	SMF100XE	NH4	32.00	29.50	41.00	700	F	SCD 30
150	SMF150XE		CONSULT FACTORY				F	SCD 30
167	SMF167XE		CONSULT FACTORY				F	SCD 30

For shielded units, please add the suffix "S" to the above part numbers.

*WALL MOUNTING KIT AND/OR DRIP PLATE KIT REQUIRED.
REFER TO PAGES 271 TO 273 FOR DETAILS.

**Note: Meets DOE 10 CFR Part 431 and C802.2 at 60 Hz.

Products listed on this page are available as 'CE Mark' products. Please consult our sales office.

FOR TERMINATION DETAILS SEE PAGE 275.

FOR ACCESSORIES SEE PAGES 271 TO 274.

Data subject to change without notice.



COPPER WOUND, SINGLE PHASE



208 Primary Volts

120/240 Secondary Volts

60 Hz

kVA	Catalog Number	Case Style (Pages 260 - 267)	Approx. Dimensions (Inches)			Approx. Weight (Lbs.)	Mtg Type W - Wall F - Floor	Wiring Diagram (Pages 276 - 288)
			Width	Depth	Height			
15	SMF015BEC	NH5	19.40	20.20	21.50	180	F or W *	SCD 32
25	SMF025BEC	NH6	23.90	25.00	28.75	240	F or W *	SCD 31
37.5	SMF037BEC	NH6	23.90	25.00	28.75	300	F or W *	SCD 31
50	SMF050BEC	NH3	26.00	25.00	38.00	375	F or W *	SCD 31
75	SMF075BEC	NH3	26.00	25.00	38.00	525	F or W *	SCD 6
100	SMF100BEC	NH4	32.00	29.50	41.00	650	F	SCD 6
150	SMF150BEC	NJ4	32.00	32.50	50.00	900	F	SCD 6
167	SMF167BEC	NJ4	32.00	32.50	50.00	1000	F	SCD 6

For shielded units, please replace the suffix "C" with a 'K' on the above part numbers.

*WALL MOUNTING KIT AND/OR DRIP PLATE KIT REQUIRED. REFER TO PAGES 271 TO 273 FOR DETAILS.

240 X 480 Primary Volts

120/240 Secondary Volts

60 Hz

kVA	Catalog Number	Case Style (Pages 260 - 267)	Approx. Dimensions (Inches)			Approx. Weight (Lbs.)	Mtg Type W - Wall F - Floor	Wiring Diagram (Pages 276 - 288)
			Width	Depth	Height			
15	SMF015LEC	NH5	19.40	20.20	21.50	180	F or W *	SCD 34
25	SMF025LEC	NH6	23.90	25.00	28.75	240	F or W *	SCD 17
37.5	SMF037LEC	NH6	23.90	25.00	28.75	300	F or W *	SCD 17
50	SMF050LEC	NH3	26.00	25.00	38.00	375	F or W *	SCD 17
75	SMF075LEC	NH3	26.00	25.00	38.00	525	F or W *	SCD 17
100	SMF100LEC	NH4	32.00	29.50	41.00	650	F	SCD 17
150	SMF150LEC	NJ4	32.00	32.50	50.00	900	F	SCD 17
167	SMF167LEC	NJ4	32.00	32.50	50.00	1000	F	SCD 17

For shielded units, please replace the suffix "C" with a 'K' on the above part numbers.

*WALL MOUNTING KIT AND/OR DRIP PLATE KIT REQUIRED. REFER TO PAGES 271 TO 273 FOR DETAILS.

277 Primary Volts

120/240 Secondary Volts

60 Hz

kVA	Catalog Number	Case Style (Pages 260 - 267)	Approx. Dimensions (Inches)			Approx. Weight (Lbs.)	Mtg Type W - Wall F - Floor	Wiring Diagram (Pages 276 - 288)
			Width	Depth	Height			
15	SMF015FEC	NH5	19.40	20.20	21.50	180	F or W *	SCD 32
25	SMF025FEC	NH6	23.90	25.00	28.75	240	F or W *	SCD 31
37.5	SMF037FEC	NH6	23.90	25.00	28.75	300	F or W *	SCD 31
50	SMF050FEC	NH3	26.00	25.00	38.00	375	F or W *	SCD 31
75	SMF075FEC	NH3	26.00	25.00	38.00	525	F or W *	SCD 6
100	SMF100FEC	NH4	32.00	29.50	41.00	650	F	SCD 6
150	SMF150FEC	NJ4	32.00	32.50	50.00	900	F	SCD 6
167	SMF167FEC	NJ4	32.00	32.50	50.00	1000	F	SCD 6

For shielded units, please replace the suffix "C" with a 'K' on the above part numbers.

*WALL MOUNTING KIT AND/OR DRIP PLATE KIT REQUIRED. REFER TO PAGES 271 TO 273 FOR DETAILS.

Products listed on this page are available as 'CE Mark' products. Please consult our sales office.

FOR TERMINATION DETAILS SEE PAGE 275.

FOR ACCESSORIES SEE PAGES 271 TO 274.



COPPER WOUND, SINGLE PHASE



416 Primary Volts

120/240 Secondary Volts

60 Hz

kVA	Catalog Number	Case Style (Pages 260 - 267)	Approx. Dimensions (Inches)			Approx. Weight (Lbs.)	Mtg Type W - Wall F - Floor	Wiring Diagram (Pages 276 - 288)
			Width	Depth	Height			
15	SMF015HEC	NH5	19.40	20.20	21.50	180	F or W *	SCD 32
25	SMF025HEC	NH6	23.90	25.00	28.75	240	F or W *	SCD 31
37.5	SMF037HEC	NH6	23.90	25.00	28.75	300	F or W *	SCD 31
50	SMF050HEC	NH3	26.00	25.00	38.00	375	F or W *	SCD 31
75	SMF075HEC	NH3	26.00	25.00	38.00	525	F or W *	SCD 6
100	SMF100HEC	NH4	32.00	29.50	41.00	650	F	SCD 6
150	SMF150HEC	NJ4	32.00	32.50	50.00	900	F	SCD 6
167	SMF167HEC	NJ4	32.00	32.50	50.00	1000	F	SCD 6

For shielded units, please replace the suffix "C" with a 'K' on the above part numbers.

*WALL MOUNTING KIT AND/OR DRIP PLATE KIT REQUIRED.
REFER TO PAGES 271 TO 273 FOR DETAILS.

600 Primary Volts

120/240 Secondary Volts

60 Hz

kVA	Catalog Number	Case Style (Pages 260 - 267)	Approx. Dimensions (Inches)			Approx. Weight (Lbs.)	Mtg Type W - Wall F - Floor	Wiring Diagram (Pages 276 - 288)
			Width	Depth	Height			
15	SMF015PEC	NH5	19.40	20.20	21.50	180	F or W *	SCD 32
25	SMF025PEC	NH6	23.90	25.00	28.75	240	F or W *	SCD 31
37.5	SMF037PEC	NH6	23.90	25.00	28.75	300	F or W *	SCD 31
50	SMF050PEC	NH3	26.00	25.00	38.00	375	F or W *	SCD 31
75	SMF075PEC	NH3	26.00	25.00	38.00	525	F or W *	SCD 6
100	SMF100PEC	NH4	32.00	29.50	41.00	650	F	SCD 6
150	SMF150PEC	NJ4	32.00	32.50	50.00	900	F	SCD 6
167	SMF167PEC	NJ4	32.00	32.50	50.00	1000	F	SCD 6

For shielded units, please replace the suffix "C" with a 'K' on the above part numbers.

*WALL MOUNTING KIT AND/OR DRIP PLATE KIT REQUIRED.
REFER TO PAGES 271 TO 273 FOR DETAILS.

SINGLE PHASE, EXPORT MODEL

190/200/208/220 X 380/400/416/440 Primary Volts

120/240 Secondary Volts

50/60 Hz**

kVA	Catalog Number	Case Style (Pages 260 - 267)	Approx. Dimensions (Inches)			Approx. Weight (Lbs.)	Mtg Type W - Wall F - Floor	Wiring Diagram (Pages 276 - 288)
			Width	Depth	Height			
15	SMF015XEC	NH6	23.90	25.00	28.75	190	F or W *	SCD 30
25	SMF025XEC	NH6	23.90	25.00	28.75	240	F or W *	SCD 30
37.5	SMF037XEC	NH6	23.90	25.00	28.75	300	F or W *	SCD 30
50	SMF050XEC	NH3	26.00	25.00	38.00	390	F or W *	SCD 30
75	SMF075XEC	NH3	26.00	25.00	38.00	540	F or W *	SCD 30
100	SMF100XEC	NH4	32.00	29.50	41.00	700	F	SCD 30
150	SMF150XEC		CONSULT FACTORY				F	SCD 30
167	SMF167XEC		CONSULT FACTORY				F	SCD 30

For shielded units, please add the suffix "S" to the above part numbers.

**Note: Meets DOE 10 CFR Part 431 and C802.2 at 60 Hz.

*WALL MOUNTING KIT AND/OR DRIP PLATE KIT REQUIRED.
REFER TO PAGES 271 TO 273 FOR DETAILS.

Products listed on this page are available as 'CE Mark' products. Please consult our sales office.

FOR TERMINATION DETAILS SEE PAGE 275.

FOR ACCESSORIES SEE PAGES 271 TO 274.

Data subject to change without notice.



HPS SUPERSENTINEL®
600 VOLT CLASS SUPER ENERGY EFFICIENT
GENERAL PURPOSE DISTRIBUTION TRANSFORMER



ALUMINUM & COPPER, THREE PHASE STANDARD SPECIFICATIONS



15 to 45 kVA



75 to 750 kVA



	15 to 45 kVA	75 to 750 kVA
Efficiency	Exceeds DOE 10 CFR Part 431 and C802.2 efficiencies at 35% of the rated load. Efficiency performance will meet the NEMA Premium® guidelines; 30% lower losses than DOE 10 CFR Part 431 and (if applicable) C802.2 efficiency standards; when measured under a linear load profile.	
UL Listed	File: E112313	File: E112313
CSA Certified	File: LR3902	File: LR3902
Frequency	60 Hz	60 Hz
Insulation System	220°C (150°C rise) 200°C (130°C rise) on 15 & 30kVA copper (optional 115°C and 80°C rise available)	220°C (150°C rise) (optional 115°C and 80°C rise available)
Enclosure Type	Heavy Duty Ventilated Type 3R Optional Type 4, 4X (stainless steel) and 12.	Heavy Duty Ventilated Type 3R Optional Type 4, 4X (stainless steel) and 12.
Enclosure Finish	ANSI 61 Grey, UL50	ANSI 61 Grey, UL50
Neutral	Neutral terminal for field connection (on applicable units).	Neutral terminal for field connection (on applicable units).
Standard Primary Taps	Refer to wiring diagrams for details.	Refer to wiring diagrams for details.
Termination	Front accessible separate high and low voltage terminals; connectors suitable for aluminum and copper are provided for easy cable installation.	Front accessible separate high and low voltage terminals; connectors suitable for aluminum and copper are provided for easy cable installation.
Conduit Knock-Outs	Standard on all units.	Standard on 75 kVA & 150 kVA units.
Impedance	Typically 2.5% to 6.5%	Typically 2.5% to 6.5%
Mounting	Floor or wall/ceiling mounting available. Refer to selection tables for details.	Floor or wall/ceiling mounting available. Refer to selection tables for details.
Seismic	Meets Occupancy Category III Ip=1.25 for Ss=1.0g per IBC 2006; section 1613, earthquake loads and NBCC 2005 for ground level installations only for all locations in North America.	Meets Occupancy Category III Ip=1.25 for Ss=1.0g per IBC 2006; section 1613, earthquake loads and NBCC 2005 for ground level installations only for all locations in North America.
Sound level	Meets NEMA ST-20 standards. (Optional low noise units available)	Meets NEMA ST-20 standards. (Optional low noise units available)

Other voltages and kVA sizes not listed in this section are available upon request for both aluminum and copper wound units. Features as listed above may differ. Please contact customer service for details, price and availability.



SECTION 7

ALUMINUM WOUND, THREE PHASE



208 Delta Primary Volts

208Y/120 Secondary Volts

60 Hz

kVA	Catalog Number	Case Style (Pages 260 - 267)	Approx. Dimensions (Inches)			Approx. Weight (Lbs.)	Mtg Type W - Wall F - Floor	Wiring Diagram (Pages 276 - 288)
			Width	Depth	Height			
15	SMK015BB	NH5	19.40	20.20	21.50	250	F or W *	SCD 7
30	SMK030BB	NH6	23.90	25.00	28.75	350	F or W *	SCD 9
45	SMK045BB	NH3	26.00	25.00	38.00	460	F or W *	SCD 9
75	SMK075BB	NH3	26.00	25.00	38.00	650	F or W *	SCD 9
112.5	SMK112BB	NH4	32.00	29.50	41.00	960	F	SCD 9
150	SMK150BB	NH4	32.00	29.50	41.00	1210	F	SCD 9
225	SMK225BB	NH4	32.00	29.50	41.00	1970	F	SCD 9
300	SMK300BB	NJ1	39.50	34.00	51.50	2590	F	SCD 9
500	SMK500BB	NJ2	48.50	38.40	59.00	4450	F	SCD 25
750	SMK750BB	NJ3	51.50	43.40	66.00	6250	F	SCD 25

For shielded units, please add the suffix "S" to the above part numbers.

*WALL MOUNTING KIT AND/OR DRIP PLATE KIT REQUIRED.
REFER TO PAGES 271 TO 273 FOR DETAILS.

208 Delta Primary Volts

480Y/277 Secondary Volts

60 Hz

kVA	Catalog Number	Case Style (Pages 260 - 267)	Approx. Dimensions (Inches)			Approx. Weight (Lbs.)	Mtg Type W - Wall F - Floor	Wiring Diagram (Pages 276 - 288)
			Width	Depth	Height			
15	SMK015BK	NH5	19.40	20.20	21.50	250	F or W *	SCD 40
30	SMK030BK	NH6	23.90	25.00	28.75	350	F or W *	SCD 26
45	SMK045BK	NH3	26.00	25.00	38.00	460	F or W *	SCD 26
75	SMK075BK	NH3	26.00	25.00	38.00	650	F or W *	SCD 26
112.5	SMK112BK	NH4	32.00	29.50	41.00	960	F	SCD 26
150	SMK150BK	NH4	32.00	29.50	41.00	1210	F	SCD 26
225	SMK225BK	NH4	32.00	29.50	41.00	1970	F	SCD 26
300	SMK300BK	NJ1	39.50	34.00	51.50	2590	F	SCD 26
500	SMK500BK	NJ2	48.50	38.40	59.00	4450	F	SCD 23
750	SMK750BK	NJ3	51.50	43.40	66.00	6250	F	SCD 40

For shielded units, please add the suffix "S" to the above part numbers.

*WALL MOUNTING KIT AND/OR DRIP PLATE KIT REQUIRED.
REFER TO PAGES 271 TO 273 FOR DETAILS.

240 Delta Primary Volts

208Y/120 Secondary Volts

60 Hz

kVA	Catalog Number	Case Style (Pages 260 - 267)	Approx. Dimensions (Inches)			Approx. Weight (Lbs.)	Mtg Type W - Wall F - Floor	Wiring Diagram (Pages 276 - 288)
			Width	Depth	Height			
15	SMK015DB	NH5	19.40	20.20	21.50	250	F or W *	SCD 25
30	SMK030DB	NH6	23.90	25.00	28.75	350	F or W *	SCD 9
45	SMK045DB	NH3	26.00	25.00	38.00	460	F or W *	SCD 9
75	SMK075DB	NH3	26.00	25.00	38.00	650	F or W *	SCD 9
112.5	SMK112DB	NH4	32.00	29.50	41.00	960	F	SCD 9
150	SMK150DB	NH4	32.00	29.50	41.00	1210	F	SCD 9
225	SMK225DB	NH4	32.00	29.50	41.00	1970	F	SCD 9
300	SMK300DB	NJ1	39.50	34.00	51.50	2590	F	SCD 9
500	SMK500DB	NJ2	48.50	38.40	59.00	4450	F	NO TAPS
750	SMK750DB	NJ3	51.50	43.40	66.00	6250	F	NO TAPS

For shielded units, please add the suffix "S" to the above part numbers.

*WALL MOUNTING KIT AND/OR DRIP PLATE KIT REQUIRED.
REFER TO PAGES 271 TO 273 FOR DETAILS.

Products listed on this page are available as 'CE Mark' products. Please consult our sales office.

FOR TERMINATION DETAILS SEE PAGE 275.

FOR ACCESSORIES SEE PAGES 271 TO 274.

Data subject to change without notice.



ALUMINUM WOUND, THREE PHASE



240 Delta Primary Volts

480Y/277 Secondary Volts

60 Hz

kVA	Catalog Number	Case Style (Pages 260 - 267)	Approx. Dimensions (Inches)			Approx. Weight (Lbs.)	Mtg Type W - Wall F - Floor	Wiring Diagram (Pages 276 - 288)
			Width	Depth	Height			
15	SMK015DK	NH5	19.40	20.20	21.50	250	F or W *	SCD 40
30	SMK030DK	NH6	23.90	25.00	28.75	350	F or W *	SCD 26
45	SMK045DK	NH3	26.00	25.00	38.00	460	F or W *	SCD 26
75	SMK075DK	NH3	26.00	25.00	38.00	650	F or W *	SCD 26
112.5	SMK112DK	NH4	32.00	29.50	41.00	960	F	SCD 26
150	SMK150DK	NH4	32.00	29.50	41.00	1210	F	SCD 26
225	SMK225DK	NH4	32.00	29.50	41.00	1970	F	SCD 26
300	SMK300DK	NJ1	39.50	34.00	51.50	2590	F	SCD 26
500	SMK500DK	NJ2	48.50	38.40	59.00	4450	F	NO TAPS
750	SMK750DK	NJ3	51.50	43.40	66.00	6250	F	NO TAPS

For shielded units, please add the suffix "S" to the above part numbers.

*WALL MOUNTING KIT AND/OR DRIP PLATE KIT REQUIRED. REFER TO PAGES 271 TO 273 FOR DETAILS.

480 Delta Primary Volts

208Y/120 Secondary Volts

60 Hz

May be used on a 4 wire 480Y/277 Volt Supply

kVA	Catalog Number	Case Style (Pages 260 - 267)	Approx. Dimensions (Inches)			Approx. Weight (Lbs.)	Mtg Type W - Wall F - Floor	Wiring Diagram (Pages 276 - 288)
			Width	Depth	Height			
15	SMK015KB	NH5	19.40	20.20	21.50	250	F or W *	SCD 7
30	SMK030KB	NH6	23.90	25.00	28.75	350	F or W *	SCD 19
45	SMK045KB	NH3	26.00	25.00	38.00	460	F or W *	SCD 19
75	SMK075KB	NH3	26.00	25.00	38.00	650	F or W *	SCD 19
112.5	SMK112KB	NH4	32.00	29.50	41.00	960	F	SCD 19
150	SMK150KB	NH4	32.00	29.50	41.00	1210	F	SCD 19
225	SMK225KB	NH4	32.00	29.50	41.00	1970	F	SCD 19
300	SMK300KB	NJ1	39.50	34.00	51.50	2590	F	SCD 19
500	SMK500KB	NJ2	48.50	38.40	59.00	4450	F	SCD 20
750	SMK750KB	NJ3	51.50	43.40	66.00	6250	F	SCD 20

For shielded units, please add the suffix "S" to the above part numbers.

*WALL MOUNTING KIT AND/OR DRIP PLATE KIT REQUIRED. REFER TO PAGES 271 TO 273 FOR DETAILS.

480 Delta Primary Volts

240 Delta/120 CT Secondary Volts

60 Hz

May be used on a 4 wire 480Y/277 Volt Supply

kVA	Catalog Number	Case Style (Pages 260 - 267)	Approx. Dimensions (Inches)			Approx. Weight (Lbs.)	Mtg Type W - Wall F - Floor	Wiring Diagram (Pages 276 - 288)
			Width	Depth	Height			
15	SMK015KD	NH5	19.40	20.20	21.50	250	F or W *	SCD 13
30	SMK030KD	NH6	23.90	25.00	28.75	350	F or W *	SCD 21
45	SMK045KD	NH3	26.00	25.00	38.00	460	F or W *	SCD 21
75	SMK075KD	NH3	26.00	25.00	38.00	650	F or W *	SCD 21
112.5	SMK112KD	NH4	32.00	29.50	41.00	960	F	SCD 21
150	SMK150KD	NH4	32.00	29.50	41.00	1210	F	SCD 21
225	SMK225KD	NH4	32.00	29.50	41.00	1970	F	SCD 21
300	SMK300KD	NJ1	39.50	34.00	51.50	2590	F	SCD 21
500	SMK500KD	NJ2	48.50	38.40	59.00	4450	F	SCD 22
750	SMK750KD	NJ3	51.50	43.40	66.00	6250	F	SCD 22

For shielded units, please add the suffix "S" to the above part numbers.

*WALL MOUNTING KIT AND/OR DRIP PLATE KIT REQUIRED. REFER TO PAGES 271 TO 273 FOR DETAILS.

Products listed on this page are available as 'CE Mark' products. Please consult our sales office.

FOR TERMINATION DETAILS SEE PAGE 275.

FOR ACCESSORIES SEE PAGES 271 TO 274.



ALUMINUM WOUND, THREE PHASE



480 Delta Primary Volts

480Y/277 Secondary Volts

60 Hz

May be used on a 4 wire 480Y/277 Volt Supply

kVA	Catalog Number	Case Style (Pages 260 - 267)	Approx. Dimensions (Inches)			Approx. Weight (Lbs.)	Mtg Type W - Wall F - Floor	Wiring Diagram (Pages 276 - 288)
			Width	Depth	Height			
15	SMK015KK	NH5	19.40	20.20	21.50	250	F or W *	SCD 25
30	SMK030KK	NH6	23.90	25.00	28.75	350	F or W *	SCD 19
45	SMK045KK	NH3	26.00	25.00	38.00	460	F or W *	SCD 19
75	SMK075KK	NH3	26.00	25.00	38.00	650	F or W *	SCD 19
112.5	SMK112KK	NH4	32.00	29.50	41.00	960	F	SCD 19
150	SMK150KK	NH4	32.00	29.50	41.00	1210	F	SCD 19
225	SMK225KK	NH4	32.00	29.50	41.00	1970	F	SCD 19
300	SMK300KK	NJ1	39.50	34.00	51.50	2590	F	SCD 19
500	SMK500KK	NJ2	48.50	38.40	59.00	4450	F	SCD 20
750	SMK750KK	NJ3	51.50	43.40	66.00	6250	F	SCD 20

For shielded units, please add the suffix "S" to the above part numbers.

*WALL MOUNTING KIT AND/OR DRIP PLATE KIT REQUIRED.
REFER TO PAGES 271 TO 273 FOR DETAILS.

600 Delta Primary Volts

208Y/120 Secondary Volts

60 Hz

May be used on a 4 wire 600Y/347 Volt Supply

kVA	Catalog Number	Case Style (Pages 260 - 267)	Approx. Dimensions (Inches)			Approx. Weight (Lbs.)	Mtg Type W - Wall F - Floor	Wiring Diagram (Pages 276 - 288)
			Width	Depth	Height			
15	SMK015PB	NH5	19.40	20.20	21.50	250	F or W *	SCD 9
30	SMK030PB	NH6	23.90	25.00	28.75	350	F or W *	SCD 9
45	SMK045PB	NH3	26.00	25.00	38.00	460	F or W *	SCD 9
75	SMK075PB	NH3	26.00	25.00	38.00	650	F or W *	SCD 9
112.5	SMK112PB	NH4	32.00	29.50	41.00	960	F	SCD 9
150	SMK150PB	NH4	32.00	29.50	41.00	1210	F	SCD 9
225	SMK225PB	NH4	32.00	29.50	41.00	1970	F	SCD 9
300	SMK300PB	NJ1	39.50	34.00	51.50	2590	F	SCD 9
500	SMK500PB	NJ2	48.50	38.40	59.00	4450	F	SCD 10
750	SMK750PB	NJ3	51.50	43.40	66.00	6250	F	SCD 10

For shielded units, please add the suffix "S" to the above part numbers.

*WALL MOUNTING KIT AND/OR DRIP PLATE KIT REQUIRED.
REFER TO PAGES 271 TO 273 FOR DETAILS.

600Y Primary Volts

240 Delta Secondary Volts

60 Hz

Do not connect neutral when used on 600Y/347 Volt Supply

kVA	Catalog Number	Case Style (Pages 260 - 267)	Approx. Dimensions (Inches)			Approx. Weight (Lbs.)	Mtg Type W - Wall F - Floor	Wiring Diagram (Pages 276 - 288)
			Width	Depth	Height			
15	SMK015PD	NH5	19.40	20.20	21.50	250	F or W *	SCD 16
30	SMK030PD	NH6	23.90	25.00	28.75	350	F or W *	SCD 16
45	SMK045PD	NH3	26.00	25.00	38.00	460	F or W *	SCD 16
75	SMK075PD	NH3	26.00	25.00	38.00	650	F or W *	SCD 16
112.5	SMK112PD	NH4	32.00	29.50	41.00	960	F	SCD 16
150	SMK150PD	NH4	32.00	29.50	41.00	1210	F	SCD 16
225	SMK225PD	NH4	32.00	29.50	41.00	1970	F	SCD 16
300	SMK300PD	NJ1	39.50	34.00	51.50	2590	F	SCD 16
500	SMK500PD	NJ2	48.50	38.40	59.00	4450	F	SCD 29
750	SMK750PD	NJ3	51.50	43.40	66.00	6250	F	SCD 29

For shielded units, please add the suffix "S" to the above part numbers.

*WALL MOUNTING KIT AND/OR DRIP PLATE KIT REQUIRED.
REFER TO PAGES 271 TO 273 FOR DETAILS.

Products listed on this page are available as 'CE Mark' products. Please consult our sales office.

FOR TERMINATION DETAILS SEE PAGE 275.

FOR ACCESSORIES SEE PAGES 271 TO 274.

Data subject to change without notice.



ALUMINUM WOUND, THREE PHASE



600 Delta Primary Volts

480Y/277 Secondary Volts

60 Hz

May be used on a 4 wire 600Y/347 Volt Supply

kVA	Catalog Number	Case Style (Pages 260 - 267)	Approx. Dimensions (Inches)			Approx. Weight (Lbs.)	Mtg Type W - Wall F - Floor	Wiring Diagram (Pages 276 - 288)
			Width	Depth	Height			
15	SMK015PK	NH5	19.40	20.20	21.50	250	F or W *	SCD 9
30	SMK030PK	NH6	23.90	25.00	28.75	350	F or W *	SCD 9
45	SMK045PK	NH3	26.00	25.00	38.00	460	F or W *	SCD 9
75	SMK075PK	NH3	26.00	25.00	38.00	650	F or W *	SCD 9
112.5	SMK112PK	NH4	32.00	29.50	41.00	960	F	SCD 9
150	SMK150PK	NH4	32.00	29.50	41.00	1210	F	SCD 9
225	SMK225PK	NH4	32.00	29.50	41.00	1970	F	SCD 9
300	SMK300PK	NJ1	39.50	34.00	51.50	2590	F	SCD 9
500	SMK500PK	NJ2	48.50	38.40	59.00	4450	F	SCD 10
750	SMK750PK	NJ3	51.50	43.40	66.00	6250	F	SCD 10

For shielded units, please add the suffix "S" to the above part numbers.

*WALL MOUNTING KIT AND/OR DRIP PLATE KIT REQUIRED. REFER TO PAGES 271 TO 273 FOR DETAILS.

SECTION 7

Products listed on this page are available as 'CE Mark' products. Please consult our sales office.

FOR TERMINATION DETAILS SEE PAGE 275.

FOR ACCESSORIES SEE PAGES 271 TO 274.



COPPER WOUND, THREE PHASE



208 Delta Primary Volts

208Y/120 Secondary Volts

60 Hz

kVA	Catalog Number	Case Style (Pages 260 - 267)	Approx. Dimensions (Inches)			Approx. Weight (Lbs.)	Mtg Type W - Wall F - Floor	Wiring Diagram (Pages 276 - 288)
			Width	Depth	Height			
15	SMK015BBCN	NH5	19.40	20.20	21.50	250	F or W *	SCD 7
30	SMK030BBC	NH6	23.90	25.00	28.75	390	F or W *	SCD 9
45	SMK045BBC	NH6	23.90	25.00	28.75	460	F or W *	SCD 9
75	SMK075BBC	NH3	26.00	25.00	38.00	660	F or W *	SCD 9
112.5	SMK112BBC	NH4	32.00	29.50	41.00	1000	F	SCD 9
150	SMK150BBC	NH4	32.00	29.50	41.00	1250	F	SCD 9
225	SMK225BBC	NJ1	39.50	34.00	51.50	1960	F	SCD 9
300	SMK300BBC	NJ2	48.50	38.40	59.00	2470	F	SCD 9
500	SMK500BBC	NJ3	51.50	43.40	66.00	3930	F	SCD 25
750	SMK750BBC	NJ6	64.00	57.40	71.00	5750	F	SCD 25

For shielded units, please replace the suffix "C" with "K" on the above part numbers.

*WALL MOUNTING KIT AND/OR DRIP PLATE KIT REQUIRED.
REFER TO PAGES 271 TO 273 FOR DETAILS.

208 Delta Primary Volts

480Y/277 Secondary Volts

60 Hz

kVA	Catalog Number	Case Style (Pages 260 - 267)	Approx. Dimensions (Inches)			Approx. Weight (Lbs.)	Mtg Type W - Wall F - Floor	Wiring Diagram (Pages 276 - 288)
			Width	Depth	Height			
15	SMK015BKCN	NH5	19.40	20.20	21.50	250	F or W *	SCD 40
30	SMK030BKC	NH6	23.90	25.00	28.75	390	F or W *	SCD 26
45	SMK045BKC	NH6	23.90	25.00	28.75	460	F or W *	SCD 26
75	SMK075BKC	NH3	26.00	25.00	38.00	660	F or W *	SCD 26
112.5	SMK112BKC	NH4	32.00	29.50	41.00	1000	F	SCD 26
150	SMK150BKC	NH4	32.00	29.50	41.00	1250	F	SCD 26
225	SMK225BKC	NJ1	39.50	34.00	51.50	1960	F	SCD 26
300	SMK300BKC	NJ2	48.50	38.40	59.00	2470	F	SCD 26
500	SMK500BKC	NJ3	51.50	43.40	66.00	3930	F	SCD 23
750	SMK750BKC	NJ6	64.00	57.40	71.00	5750	F	SCD 40

For shielded units, please replace the suffix "C" with "K" on the above part numbers.

*WALL MOUNTING KIT AND/OR DRIP PLATE KIT REQUIRED.
REFER TO PAGES 271 TO 273 FOR DETAILS.

240 Delta Primary Volts

208Y/120 Secondary Volts

60 Hz

kVA	Catalog Number	Case Style (Pages 260 - 267)	Approx. Dimensions (Inches)			Approx. Weight (Lbs.)	Mtg Type W - Wall F - Floor	Wiring Diagram (Pages 276 - 288)
			Width	Depth	Height			
15	SMK015DBCN	NH5	19.40	20.20	21.50	250	F or W *	SCD 25
30	SMK030DBC	NH6	23.90	25.00	28.75	390	F or W *	SCD 9
45	SMK045DBC	NH6	23.90	25.00	28.75	460	F or W *	SCD 9
75	SMK075DBC	NH3	26.00	25.00	38.00	660	F or W *	SCD 9
112.5	SMK112DBC	NH4	32.00	29.50	41.00	1000	F	SCD 9
150	SMK150DBC	NH4	32.00	29.50	41.00	1250	F	SCD 9
225	SMK225DBC	NJ1	39.50	34.00	51.50	1960	F	SCD 9
300	SMK300DBC	NJ2	48.50	38.40	59.00	2470	F	SCD 9
500	SMK500DBC	NJ3	51.50	43.40	66.00	3930	F	NO TAPS
750	SMK750DBC	NJ6	64.00	57.40	71.00	5750	F	NO TAPS

For shielded units, please replace the suffix "C" with "K" on the above part numbers.

*WALL MOUNTING KIT AND/OR DRIP PLATE KIT REQUIRED.
REFER TO PAGES 271 TO 273 FOR DETAILS.

Products listed on this page are available as 'CE Mark' products. Please consult our sales office.

FOR TERMINATION DETAILS SEE PAGE 275.

FOR ACCESSORIES SEE PAGES 271 TO 274.

Data subject to change without notice.



COPPER WOUND, THREE PHASE



240 Delta Primary Volts

480Y/277 Secondary Volts

60 Hz

kVA	Catalog Number	Case Style (Pages 260 - 267)	Approx. Dimensions (Inches)			Approx. Weight (Lbs.)	Mtg Type W - Wall F - Floor	Wiring Diagram (Pages 276 - 288)
			Width	Depth	Height			
15	SMK015DKCN	NH5	19.40	20.20	21.50	250	F or W *	SCD 40
30	SMK030DKC	NH6	23.90	25.00	28.75	390	F or W *	SCD 26
45	SMK045DKC	NH6	23.90	25.00	28.75	460	F or W *	SCD 26
75	SMK075DKC	NH3	26.00	25.00	38.00	660	F or W *	SCD 26
112.5	SMK112DKC	NH4	32.00	29.50	41.00	1000	F	SCD 26
150	SMK150DKC	NH4	32.00	29.50	41.00	1250	F	SCD 26
225	SMK225DKC	NJ1	39.50	34.00	51.50	1960	F	SCD 26
300	SMK300DKC	NJ2	48.50	38.40	59.00	2470	F	SCD 26
500	SMK500DKC	NJ3	51.50	43.40	66.00	3930	F	NO TAPS
750	SMK750DKC	NJ6	64.00	57.40	71.00	5750	F	NO TAPS

For shielded units, please replace the suffix "C" with "K" on the above part numbers.

*WALL MOUNTING KIT AND/OR DRIP PLATE KIT REQUIRED. REFER TO PAGES 271 TO 273 FOR DETAILS.

480 Delta Primary Volts

208Y/120 Secondary Volts

60 Hz

May be used on a 4 wire 480Y/277 Volt Supply

kVA	Catalog Number	Case Style (Pages 260 - 267)	Approx. Dimensions (Inches)			Approx. Weight (Lbs.)	Mtg Type W - Wall F - Floor	Wiring Diagram (Pages 276 - 288)
			Width	Depth	Height			
15	SMK015KBCN	NH5	19.40	20.20	21.50	250	F or W *	SCD 7
30	SMK030KBCN	NH6	23.90	25.00	28.75	390	F or W *	SCD 19
45	SMK045KBC	NH6	23.90	25.00	28.75	460	F or W *	SCD 19
75	SMK075KBC	NH3	26.00	25.00	38.00	660	F or W *	SCD 19
112.5	SMK112KBC	NH4	32.00	29.50	41.00	1000	F	SCD 19
150	SMK150KBC	NH4	32.00	29.50	41.00	1250	F	SCD 19
225	SMK225KBC	NJ1	39.50	34.00	51.50	1960	F	SCD 19
300	SMK300KBC	NJ2	48.50	38.40	59.00	2470	F	SCD 19
500	SMK500KBC	NJ3	51.50	43.40	66.00	3930	F	SCD 19
750	SMK750KBC	NJ6	64.00	57.40	71.00	5750	F	SCD 19

For shielded units, please replace the suffix "C" with "K" on the above part numbers.

*WALL MOUNTING KIT AND/OR DRIP PLATE KIT REQUIRED. REFER TO PAGES 271 TO 273 FOR DETAILS.

480 Delta Primary Volts

240 Delta/120 CT Secondary Volts

60 Hz

May be used on a 4 wire 480Y/277 Volt Supply

kVA	Catalog Number	Case Style (Pages 260 - 267)	Approx. Dimensions (Inches)			Approx. Weight (Lbs.)	Mtg Type W - Wall F - Floor	Wiring Diagram (Pages 276 - 288)
			Width	Depth	Height			
15	SMK015KDCN	NH5	19.40	20.20	21.50	250	F or W *	SCD 13
30	SMK030KDCN	NH6	23.90	25.00	28.75	390	F or W *	SCD 21
45	SMK045KDC	NH6	23.90	25.00	28.75	460	F or W *	SCD 21
75	SMK075KDC	NH3	26.00	25.00	38.00	660	F or W *	SCD 21
112.5	SMK112KDC	NH4	32.00	29.50	41.00	1000	F	SCD 21
150	SMK150KDC	NH4	32.00	29.50	41.00	1250	F	SCD 21
225	SMK225KDC	NJ1	39.50	34.00	51.50	1960	F	SCD 21
300	SMK300KDC	NJ2	48.50	38.40	59.00	2470	F	SCD 21
500	SMK500KDC	NJ3	51.50	43.40	66.00	3930	F	SCD 22
750	SMK750KDC	NJ6	64.00	57.40	71.00	5750	F	SCD 22

For shielded units, please replace the suffix "C" with "K" on the above part numbers.

*WALL MOUNTING KIT AND/OR DRIP PLATE KIT REQUIRED. REFER TO PAGES 271 TO 273 FOR DETAILS.

Products listed on this page are available as 'CE Mark' products. Please consult our sales office.

FOR TERMINATION DETAILS SEE PAGE 275.

FOR ACCESSORIES SEE PAGES 271 TO 274.



SECTION 7

COPPER WOUND, THREE PHASE



480 Delta Primary Volts

480Y/277 Secondary Volts

60 Hz

May be used on a 4 wire 480Y/277 Volt Supply

kVA	Catalog Number	Case Style (Pages 260 - 267)	Approx. Dimensions (Inches)			Approx. Weight (Lbs.)	Mtg Type W - Wall F - Floor	Wiring Diagram (Pages 276 - 288)
			Width	Depth	Height			
15	SMK015KCCN	NH5	19.40	20.20	21.50	250	F or W *	SCD 25
30	SMK030KCCN	NH6	23.90	25.00	28.75	390	F or W *	SCD 19
45	SMK045KCC	NH6	23.90	25.00	28.75	460	F or W *	SCD 19
75	SMK075KCC	NH3	26.00	25.00	38.00	660	F or W *	SCD 19
112.5	SMK112KCC	NH4	32.00	29.50	41.00	1000	F	SCD 19
150	SMK150KCC	NH4	32.00	29.50	41.00	1250	F	SCD 19
225	SMK225KCC	NJ1	39.50	34.00	51.50	1960	F	SCD 19
300	SMK300KCC	NJ2	48.50	38.40	59.00	2470	F	SCD 19
500	SMK500KCC	NJ3	51.50	43.40	66.00	3930	F	SCD 20
750	SMK750KCC	NJ6	64.00	57.40	71.00	5750	F	SCD 20

For shielded units, please replace the suffix "C" with "K" on the above part numbers.

*WALL MOUNTING KIT AND/OR DRIP PLATE KIT REQUIRED. REFER TO PAGES 271 TO 273 FOR DETAILS.

600 Delta Primary Volts

208Y/120 Secondary Volts

60 Hz

May be used on a 4 wire 600Y/347 Volt Supply

kVA	Catalog Number	Case Style (Pages 260 - 267)	Approx. Dimensions (Inches)			Approx. Weight (Lbs.)	Mtg Type W - Wall F - Floor	Wiring Diagram (Pages 276 - 288)
			Width	Depth	Height			
15	SMK015PBCN	NH5	19.40	20.20	21.50	250	F or W *	SCD 9
30	SMK030PBCN	NH6	23.90	25.00	28.75	390	F or W *	SCD 9
45	SMK045PBC	NH6	23.90	25.00	28.75	460	F or W *	SCD 9
75	SMK075PBC	NH3	26.00	25.00	38.00	660	F or W *	SCD 9
112.5	SMK112PBC	NH4	32.00	29.50	41.00	1000	F	SCD 9
150	SMK150PBC	NH4	32.00	29.50	41.00	1250	F	SCD 9
225	SMK225PBC	NJ1	39.50	34.00	51.50	1960	F	SCD 9
300	SMK300PBC	NJ2	48.50	38.40	59.00	2470	F	SCD 9
500	SMK500PBC	NJ3	51.50	43.40	66.00	3930	F	SCD 10
750	SMK750PBC	NJ6	64.00	57.40	71.00	5750	F	SCD 10

For shielded units, please replace the suffix "C" with "K" on the above part numbers.

*WALL MOUNTING KIT AND/OR DRIP PLATE KIT REQUIRED. REFER TO PAGES 271 TO 273 FOR DETAILS.

600Y Primary Volts

240 Delta Secondary Volts

60 Hz

Do not connect neutral when used on 600Y/347 Volt Supply

kVA	Catalog Number	Case Style (Pages 260 - 267)	Approx. Dimensions (Inches)			Approx. Weight (Lbs.)	Mtg Type W - Wall F - Floor	Wiring Diagram (Pages 276 - 288)
			Width	Depth	Height			
15	SMK015PDCN	NH5	19.40	20.20	21.50	250	F or W *	SCD 16
30	SMK030PDC	NH6	23.90	25.00	28.75	390	F or W *	SCD 16
45	SMK045PDC	NH6	23.90	25.00	28.75	460	F or W *	SCD 16
75	SMK075PDC	NH3	26.00	25.00	38.00	660	F or W *	SCD 16
112.5	SMK112PDC	NH4	32.00	29.50	41.00	1000	F	SCD 16
150	SMK150PDC	NH4	32.00	29.50	41.00	1250	F	SCD 16
225	SMK225PDC	NJ1	39.50	34.00	51.50	1960	F	SCD 16
300	SMK300PDC	NJ2	48.50	38.40	59.00	2470	F	SCD 16
500	SMK500PDC	NJ3	51.50	43.40	66.00	3930	F	SCD 29
750	SMK750PDC	NJ6	64.00	57.40	71.00	5750	F	SCD 29

For shielded units, please replace the suffix "C" with "K" on the above part numbers.

*WALL MOUNTING KIT AND/OR DRIP PLATE KIT REQUIRED. REFER TO PAGES 271 TO 273 FOR DETAILS.

Products listed on this page are available as 'CE Mark' products. Please consult our sales office.

FOR TERMINATION DETAILS SEE PAGE 275.

FOR ACCESSORIES SEE PAGES 271 TO 274.

Data subject to change without notice.



COPPER WOUND, THREE PHASE



600 Delta Primary Volts

480Y/277 Secondary Volts

60 Hz

May be used on a 4 wire 600Y/347 Volt Supply

kVA	Catalog Number	Case Style (Pages 260 - 267)	Approx. Dimensions (Inches)			Approx. Weight (Lbs.)	Mtg Type W - Wall F - Floor	Wiring Diagram (Pages 276 - 288)
			Width	Depth	Height			
15	SMK015PKCN	NH5	19.40	20.20	21.50	250	F or W *	SCD 9
30	SMK030PKCN	NH6	23.90	25.00	28.75	390	F or W *	SCD 9
45	SMK045PKC	NH6	23.90	25.00	28.75	460	F or W *	SCD 9
75	SMK075PKC	NH3	26.00	25.00	38.00	660	F or W *	SCD 9
112.5	SMK112PKC	NH4	32.00	29.50	41.00	1000	F	SCD 9
150	SMK150PKC	NH4	32.00	29.50	41.00	1250	F	SCD 9
225	SMK225PKC	NJ1	39.50	34.00	51.50	1960	F	SCD 9
300	SMK300PKC	NJ2	48.50	38.40	59.00	2470	F	SCD 9
500	SMK500PKC	NJ3	51.50	43.40	66.00	3930	F	SCD 10
750	SMK750PKC	NJ6	64.00	57.40	71.00	5750	F	SCD 10

For shielded units, please replace the suffix "C" with "K" on the above part numbers.

*WALL MOUNTING KIT AND/OR DRIP PLATE KIT REQUIRED.
REFER TO PAGES 271 TO 273 FOR DETAILS.

SECTION 7

Products listed on this page are available as 'CE Mark' products. Please consult our sales office.

FOR TERMINATION DETAILS SEE PAGE 275.

FOR ACCESSORIES SEE PAGES 271 TO 274.



HPS SYNERGY® Series

600V CLASS ENERGY EFFICIENT K-FACTOR TRANSFORMER

The use of electronic equipment has continued to proliferate in both offices and industrial plants. These electronic devices are powered by either switching power supplies or a rectifier circuit. Examples of these devices include computers, fax machines, copiers, printers, cash registers, UPS's and solid-state ballasts. They all contribute to the distortion of the current waveform and the generation of harmonics.

HARMONICS AND NON-LINEAR LOADS

Harmonics, in an electrical system, are currents created by non-linear loads that generate non-sinusoidal (non-linear) current waveforms. These current and voltage waveforms operate on frequencies that are in multiples of the fundamental 60 hertz frequency. That is, the fundamental frequency is at 60 hertz, the 2nd harmonic is at 120 hertz frequency (60 x 2), the 3rd at 180 hertz, and so forth.

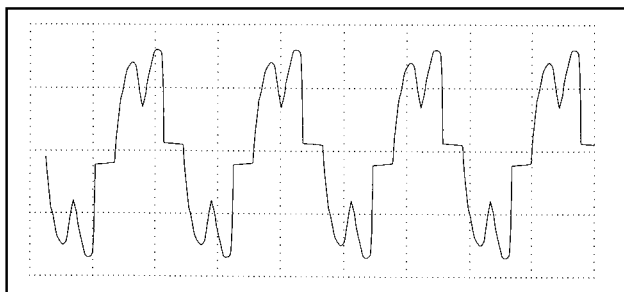

An example of harmonics

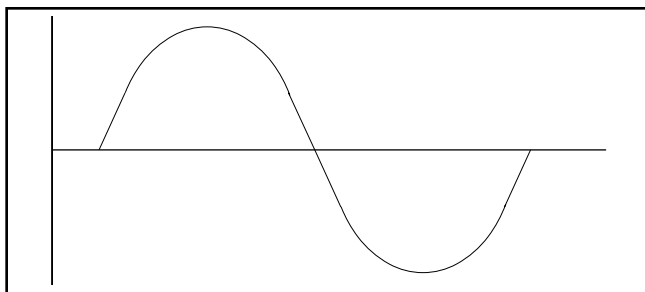

An example of a perfect waveform

Harmonics are principally the by-product of switch-mode power supply technology where AC is rectified to DC, and back again. In the process, a capacitor is charged in the first half-cycle and then discharged in the next half-cycle in supplying current to the load. This cycle is repeated. This action of recharging causes AC current to flow only during a portion of the AC voltage wave in abrupt pulses. These abrupt pulses distort the fundamental wave shape causing distortion to the various harmonic frequencies.

Non-Linear Loads

Today, non-linear loads make up the majority of all electrical demand. Rectified input, switching power supplies and electronic lighting ballasts are the most common single phase non-linear loads. Harmonic currents and voltages produced by single phase, non-linear loads which are connected phase-to-neutral in a three phase four wire system, are third order, zero sequence harmonics (the third harmonic and its odd multiples - 3rd, 9th, 15th, 21st, etc., phasors displaced by zero degrees). These third order, zero sequence harmonic currents do not cancel, but add up arithmetically on the neutral bus, creating a primary source of excessive neutral current.

HPS SYNERGY® Series

600V CLASS ENERGY EFFICIENT K-FACTOR TRANSFORMER continued...

Energy efficient general purpose distribution transformers, most frequently used for applications such as commercial or institutional buildings, will supply widely varied single phase loads. Energy Efficient K-Factor transformers are energy efficient general purpose transformers, but are designed to tolerate the harmonic distortion associated with these loads.

Harmonics indicate their presence in a number of ways:

- Overheating
- Device malfunctions
- Telephone interference
- Equipment vibration
- Breakers tripping

Harmonics For A 60Hz System

In a 60 Hz power system, the fundamental and harmonic frequencies are outlined in the table below.

Fundamental	60 Hz
2nd Harmonic	120 Hz
3rd Harmonic	180 Hz
4th Harmonic	240 Hz
5th Harmonic	300 Hz
6th Harmonic	360 Hz
7th Harmonic	420 Hz
8th Harmonic	480 Hz
9th Harmonic	540 Hz
10th Harmonic	600 Hz
11th Harmonic	660 Hz
12th Harmonic	720 Hz
13th Harmonic	780 Hz

14th Harmonic	840 Hz
15th Harmonic	900 Hz
16th Harmonic	960 Hz
17th Harmonic	1020 Hz
18th Harmonic	1080 Hz
19th Harmonic	1140 Hz
20th Harmonic	1200 Hz
21st Harmonic	1260 Hz
22nd Harmonic	1320 Hz
23rd Harmonic	1380 Hz
24th Harmonic	1440 Hz
25th Harmonic	1500 Hz

K-Factor

K-factor is defined as a ratio between the additional losses due to harmonics and the eddy current losses at 60Hz. It is used to specify transformers for non-linear loads. Transformers with a rated K-factor of 4, 7, 13, 20 and 30 are available. For balanced loading, a transformer with a K-factor of 4 should be specified when no more than 50% of the total load is non-linear. A transformer with K-factor 13 should be specified when 100% of the load is non-linear.

HPS SYNERGY®

600 VOLT CLASS ENERGY EFFICIENT K-FACTOR TRANSFORMERS

K-Factor Transformer Efficiencies:

HPS SYNERGY (PART NUMBER PREFIX NMT)

Energy efficient k-factor transformers are designed to tolerate heating due to harmonics associated with non-linear loads. Harmonics can indicate their presence in a number of ways: overheating, device malfunctions; telephone interference; equipment vibration; and breakers tripping.

- Meets **DOE 10 CFR Part 431** and **C802.2** efficiencies at **35%** of rated load.
- Efficiencies are calculated under a **linear load profile**.
- Copper and Aluminum Available.



HPS SYNERGY® 600V CLASS ENERGY EFFICIENT K-FACTOR TRANSFORMERS

ALUMINUM & COPPER, THREE PHASE STANDARD SPECIFICATIONS

15 to 45 kVA



75 to 750 kVA



	15 to 45 kVA	75 to 750 kVA
Efficiency	Meets DOE 10 CFR Part 431 & C802.2 efficiencies at 35% of rated load. Efficiencies are calculated under a linear load profile.	
UL Listed	File: E112313	File: E112313
CSA Certified	File: LR3902	File: LR3902
Frequency	60 Hz	60 Hz
Insulation System	220°C (150°C rise) 200°C (130°C rise) on 15 & 30kVA copper (optional 115°C and 80°C rise available)	220°C (150°C rise) (optional 115°C and 80°C rise available)
Electrostatic Shield	60dB Common Mode - typical	60dB Common Mode - typical
Enclosure Type	Heavy Duty Ventilated Type 3R Optional Type 4, 4X (stainless steel) and 12.	Heavy Duty Ventilated Type 3R Optional Type 4, 4X (stainless steel) and 12.
Enclosure Finish	ANSI 61 Grey, UL50	ANSI 61 Grey, UL50
Neutral	Neutral terminal for field connection (on applicable units).	Neutral terminal for field connection (on applicable units).
Standard Primary Taps	Refer to wiring diagrams for details.	Refer to wiring diagrams for details.
Termination	Front accessible separate high and low voltage terminals; connectors suitable for aluminum and copper are provided for easy cable installation.	Front accessible separate high and low voltage terminals; connectors suitable for aluminum and copper are provided for easy cable installation.
Conduit Knock-Outs	Standard on all units.	Standard on 75 kVA & 225 kVA units.
Impedance	Typically 2.5% to 6.5%	Typically 2.5% to 6.5%
Mounting	Floor or wall/ceiling mounting available. Refer to selection tables for details.	Floor or wall/ceiling mounting available. Refer to selection tables for details.
Seismic	Meets Occupancy Category III $I_p=1.25$ for $S_s=1.0g$ per IBC 2006; section 1613, earthquake loads and NBCC 2005 for ground level installations only for all locations in North America.	Meets Occupancy Category III $I_p=1.25$ for $S_s=1.0g$ per IBC 2006; section 1613, earthquake loads and NBCC 2005 for ground level installations only for all locations in North America.
Sound level	Meets NEMA ST-20 standards. (Optional low noise units available)	Meets NEMA ST-20 standards. (Optional low noise units available)

Other voltages and kVA sizes not listed in this section are available upon request for both aluminum and copper wound units. Features as listed above may differ. Please contact customer service for details, price and availability.



ALUMINUM WOUND, SHIELDED, THREE PHASE

K-FACTOR 4

480 Delta Primary Volts

208Y/120 Secondary Volts

60 Hz

May be used on a 4 wire 480Y/277 Volt Supply

kVA	Catalog Number	Case Style (Pages 260 - 267)	Approx. Dimensions (Inches)			Approx. Weight (Lbs.)	Mtg Type W - Wall F - Floor	Wiring Diagram (Pages 276 - 288)
			Width	Depth	Height			
15	NMT04K015KBS	NH5	19.40	20.20	21.50	190	F or W *	SCD 7
30	NMT04K030KBS	NH6	23.90	25.00	28.75	330	F or W *	SCD 19
45	NMT04K045KBS	NH6	23.90	25.00	28.75	430	F or W *	SCD 19
75	NMT04K075KBS	NH3	26.00	25.00	38.00	640	F or W *	SCD 19
112.5	NMT04K112KBS	NH3	26.00	25.00	38.00	920	F	SCD 19
150	NMT04K150KBS	NH4	32.00	29.50	41.00	1050	F	SCD 19
225	NMT04K225KBS	NH4	32.00	29.50	41.00	1575	F	SCD 19
300	NMT04K300KBS	NJ1	39.50	34.00	51.50	1830	F	SCD 19
500	NMT04K500KBS	NJ2	48.50	38.40	59.00	2150	F	SCD 20
750	NMT04K750KBS	NJ3	51.50	43.40	66.00	3375	F	SCD 20

*WALL MOUNTING KIT AND/OR DRIP PLATE KIT REQUIRED. REFER TO PAGES 271 TO 273 FOR DETAILS.

600 Delta Primary Volts

208Y/120 Secondary Volts

60 Hz

May be used on a 4 wire 600Y/347 Volt Supply

kVA	Catalog Number	Case Style (Pages 260 - 267)	Approx. Dimensions (Inches)			Approx. Weight (Lbs.)	Mtg Type W - Wall F - Floor	Wiring Diagram (Pages 276 - 288)
			Width	Depth	Height			
15	NMT04K015PBS	NH5	19.40	20.20	21.50	190	F or W *	SCD 9
30	NMT04K030PBS	NH6	23.90	25.00	28.75	330	F or W *	SCD 9
45	NMT04K045PBS	NH6	23.90	25.00	28.75	430	F or W *	SCD 9
75	NMT04K075PBS	NH3	26.00	25.00	38.00	640	F or W *	SCD 9
112.5	NMT04K112PBS	NH3	26.00	25.00	38.00	920	F	SCD 9
150	NMT04K150PBS	NH4	32.00	29.50	41.00	1050	F	SCD 9
225	NMT04K225PBS	NH4	32.00	29.50	41.00	1575	F	SCD 9
300	NMT04K300PBS	NJ1	39.50	34.00	51.50	1830	F	SCD 9
500	NMT04K500PBS	NJ2	48.50	38.40	59.00	3000	F	SCD 10
750	NMT04K750PBS	NJ3	51.50	43.40	66.00	3375	F	SCD 10

*WALL MOUNTING KIT AND/OR DRIP PLATE KIT REQUIRED. REFER TO PAGES 271 TO 273 FOR DETAILS.

COPPER WOUND, SHIELDED, THREE PHASE

K-FACTOR 4

480 Delta Primary Volts

208Y/120 Secondary Volts

60 Hz

May be used on a 4 wire 480Y/277 Volt Supply

kVA	Catalog Number	Case Style (Pages 260 - 267)	Approx. Dimensions (Inches)			Approx. Weight (Lbs.)	Mtg Type W - Wall F - Floor	Wiring Diagram (Pages 276 - 288)
			Width	Depth	Height			
15	NMT04K015KBKF	NH5	19.40	20.20	21.50	210	F or W *	SCD 7
30	NMT04K030KBKN	NH6	23.90	25.00	28.75	350	F or W *	SCD 19
45	NMT04K045KBK	NH6	23.90	25.00	28.75	460	F or W *	SCD 19
75	NMT04K075KBK	NH3	26.00	25.00	38.00	665	F or W *	SCD 19
112.5	NMT04K112KBK	NH3	26.00	25.00	38.00	945	F	SCD 19
150	NMT04K150KBK	NH4	32.00	29.50	41.00	1070	F	SCD 19
225	NMT04K225KBK	NH4	32.00	29.50	41.00	1725	F	SCD 19
300	NMT04K300KBK	NJ1	39.50	34.00	51.50	1925	F	SCD 19
500	NMT04K500KBK	NJ2	48.50	38.40	59.00	2500	F	SCD 20
750	NMT04K750KBK	NJ3	51.50	43.40	66.00	3300	F	SCD 20

*WALL MOUNTING KIT AND/OR DRIP PLATE KIT REQUIRED. REFER TO PAGES 271 TO 273 FOR DETAILS.

600 Delta Primary Volts

208Y/120 Secondary Volts

60 Hz

May be used on a 4 wire 600Y/347 Volt Supply

kVA	Catalog Number	Case Style (Pages 260 - 267)	Approx. Dimensions (Inches)			Approx. Weight (Lbs.)	Mtg Type W - Wall F - Floor	Wiring Diagram (Pages 276 - 288)
			Width	Depth	Height			
15	NMT04K015PBKF	NH5	19.40	20.20	21.50	210	F or W *	SCD 9
30	NMT04K030PBKN	NH6	23.90	25.00	28.75	350	F or W *	SCD 9
45	NMT04K045PBK	NH6	23.90	25.00	28.75	460	F or W *	SCD 19
75	NMT04K075PBK	NH3	26.00	25.00	38.00	665	F or W *	SCD 9
112.5	NMT04K112PBK	NH3	26.00	25.00	38.00	945	F	SCD 9
150	NMT04K150PBK	NH4	32.00	29.50	41.00	1070	F	SCD 9
225	NMT04K225PBK	NJ1	39.50	34.00	51.50	1725	F	SCD 9
300	NMT04K300PBK	NJ1	39.50	34.00	51.50	1925	F	SCD 9
500	NMT04K500PBK	NJ2	48.50	38.40	59.00	2925	F	SCD 10
750	NMT04K750PBK	NJ3	51.50	43.40	66.00	3375	F	SCD 10

*WALL MOUNTING KIT AND/OR DRIP PLATE KIT REQUIRED. REFER TO PAGES 271 TO 273 FOR DETAILS.

Products listed on this page are available as 'CE Mark' products. Please consult our sales office.

FOR TERMINATION DETAILS SEE PAGE 275.

FOR ACCESSORIES SEE PAGES 271 TO 274.

Data subject to change without notice.





ALUMINUM WOUND, SHIELDED, THREE PHASE

K-FACTOR 13

480 Delta Primary Volts

208Y/120 Secondary Volts

60 Hz

May be used on a 4 wire 480Y/277 Volt Supply

kVA	Catalog Number	Case Style (Pages 260 - 267)	Approx. Dimensions (Inches)			Approx. Weight (Lbs.)	Mtg Type W - Wall F - Floor	Wiring Diagram (Pages 276 - 288)
			Width	Depth	Height			
15	NMT13K015KBS	NH6	23.90	25.00	28.75	190	F or W *	SCD 19
30	NMT13K030KBS	NH6	23.90	25.00	28.75	340	F or W *	SCD 19
45	NMT13K045KBS	NH6	23.90	25.00	28.75	410	F or W *	SCD 19
75	NMT13K075KBS	NH3	26.00	25.00	38.00	675	F or W *	SCD 19
112.5	NMT13K112KBS	NH4	32.00	29.50	41.00	920	F	SCD 19
150	NMT13K150KBS	NH4	32.00	29.50	41.00	1050	F	SCD 19
225	NMT13K225KBS	NJ1	39.50	34.00	51.50	1600	F	SCD 19
300	NMT13K300KBS	NJ1	39.50	34.00	51.50	1830	F	SCD 20
500	NMT13K500KBS	NJ3	51.50	43.40	66.00	3000	F	SCD 20
750	NMT13K750KBS	NJ3	51.50	43.40	66.00	4300	F	SCD 10

*WALL MOUNTING KIT AND/OR DRIP PLATE KIT REQUIRED. REFER TO PAGES 271 TO 273 FOR DETAILS.

600 Delta Primary Volts

208Y/120 Secondary Volts

60 Hz

May be used on a 4 wire 600Y/347 Volt Supply

kVA	Catalog Number	Case Style (Pages 260 - 267)	Approx. Dimensions (Inches)			Approx. Weight (Lbs.)	Mtg Type W - Wall F - Floor	Wiring Diagram (Pages 276 - 288)
			Width	Depth	Height			
15	NMT13K015PBS	NH5	19.40	20.20	21.50	190	F or W *	SCD 9
30	NMT13K030PBS	NH6	23.90	25.00	28.75	340	F or W *	SCD 9
45	NMT13K045PBS	NH6	23.90	25.00	28.75	410	F or W *	SCD 9
75	NMT13K075PBS	NH3	26.00	25.00	38.00	675	F or W *	SCD 9
112.5	NMT13K112PBS	NH4	32.00	29.50	41.00	920	F	SCD 9
150	NMT13K150PBS	NH4	32.00	29.50	41.00	1050	F	SCD 9
225	NMT13K225PBS	NJ1	39.50	34.00	51.50	1600	F	SCD 9
300	NMT13K300PBS	NJ1	39.50	34.00	51.50	1900	F	SCD 9
500	NMT13K500PBS	NJ3	51.50	43.40	66.00	3000	F	SCD 10
750	NMT13K750PBS	NJ3	51.50	43.40	66.00	4300	F	SCD 10

*WALL MOUNTING KIT AND/OR DRIP PLATE KIT REQUIRED. REFER TO PAGES 271 TO 273 FOR DETAILS.

COPPER WOUND, SHIELDED, THREE PHASE

K-FACTOR 13

480 Delta Primary Volts

208Y/120 Secondary Volts

60 Hz

May be used on a 4 wire 480Y/277 Volt Supply

kVA	Catalog Number	Case Style (Pages 260 - 267)	Approx. Dimensions (Inches)			Approx. Weight (Lbs.)	Mtg Type W - Wall F - Floor	Wiring Diagram (Pages 276 - 288)
			Width	Depth	Height			
15	NMT13K015KBKF	NH6	23.90	25.00	28.75	280	F or W *	SCD 19
30	NMT13K030KBKN	NH6	23.90	25.00	28.75	350	F or W *	SCD 19
45	NMT13K045KBK	NH6	23.90	25.00	28.75	470	F or W *	SCD 19
75	NMT13K075KBK	NH3	26.00	25.00	38.00	680	F or W *	SCD 19
112.5	NMT13K112KBK	NH4	32.00	29.50	41.00	970	F	SCD 19
150	NMT13K150KBK	NH4	32.00	29.50	41.00	1200	F	SCD 19
225	NMT13K225KBK	NJ1	39.50	34.00	51.50	1900	F	SCD 19
300	NMT13K300KBK	NJ1	39.50	34.00	51.50	2150	F	SCD 19
500	NMT13K500KBK	NJ2	51.50	43.40	66.00	3200	F	SCD 20
750	NMT13K750KBK	NJ3	51.50	43.40	66.00	4500	F	SCD 20

*WALL MOUNTING KIT AND/OR DRIP PLATE KIT REQUIRED. REFER TO PAGES 271 TO 273 FOR DETAILS.

600 Delta Primary Volts

208Y/120 Secondary Volts

60 Hz

May be used on a 4 wire 600Y/347 Volt Supply

kVA	Catalog Number	Case Style (Pages 260 - 267)	Approx. Dimensions (Inches)			Approx. Weight (Lbs.)	Mtg Type W - Wall F - Floor	Wiring Diagram (Pages 276 - 288)
			Width	Depth	Height			
15	NMT13K015PBKF	NH6	23.90	25.00	28.75	295	F or W *	SCD 9
30	NMT13K030PBKN	NH6	23.90	25.00	28.75	350	F or W *	SCD 9
45	NMT13K045PBK	NH6	23.90	25.00	28.75	480	F or W *	SCD 19
75	NMT13K075PBK	NH3	26.00	25.00	38.00	700	F or W *	SCD 9
112.5	NMT13K112PBK	NH4	32.00	29.50	41.00	970	F	SCD 9
150	NMT13K150PBK	NH4	32.00	29.50	41.00	1200	F	SCD 9
225	NMT13K225PBK	NJ1	39.50	34.00	51.50	1900	F	SCD 9
300	NMT13K300PBK	NJ1	39.50	34.00	51.50	2400	F	SCD 9
500	NMT13K500PBK	NJ2	51.50	43.40	66.00	3200	F	SCD 10
750	NMT13K750PBK	NJ3	51.50	43.40	66.00	4500	F	SCD 10

*WALL MOUNTING KIT AND/OR DRIP PLATE KIT REQUIRED. REFER TO PAGES 271 TO 273 FOR DETAILS.

Products listed on this page are available as 'CE Mark' products. Please consult our sales office.

FOR TERMINATION DETAILS SEE PAGE 275.

FOR ACCESSORIES SEE PAGES 271 TO 274.



SECTION 7



ALUMINUM WOUND, SHIELDED, THREE PHASE K-FACTOR 20

480 Delta Primary Volts

208Y/120 Secondary Volts

60 Hz

May be used on a 4 wire 480Y/277 Volt Supply

kVA	Catalog Number	Case Style (Pages 260 - 267)	Approx. Dimensions (Inches)			Approx. Weight (Lbs.)	Mtg Type W - Wall F - Floor	Wiring Diagram (Pages 276 - 288)
			Width	Depth	Height			
15	NMT20K015KBS	NH6	23.90	25.00	28.75	275	F or W *	SCD 19
30	NMT20K030KBS	NH6	23.90	25.00	28.75	365	F or W *	SCD 19
45	NMT20K045KBS	NH3	26.00	25.00	38.00	565	F or W *	SCD 19
75	NMT20K075KBS	NH3	26.00	25.00	38.00	730	F or W *	SCD 19
112.5	NMT20K112KBS	NH4	32.00	29.50	41.00	950	F	SCD 19
150	NMT20K150KBS	NH4	32.00	29.50	41.00	1400	F	SCD 19
225	NMT20K225KBS	NJ1	39.50	34.00	51.50	1900	F	SCD 19
300	NMT20K300KBS	NJ2	48.50	38.40	59.00	2400	F	SCD 20
500	NMT20K500KBS	NJ3	51.50	43.40	66.00	3600	F	SCD 20
750	NMT20K750KBS			CONSULT FACTORY				

*WALL MOUNTING KIT AND/OR DRIP PLATE KIT REQUIRED. REFER TO PAGES 271 TO 273 FOR DETAILS.

600 Delta Primary Volts

208Y/120 Secondary Volts

60 Hz

May be used on a 4 wire 600Y/347 Volt Supply

kVA	Catalog Number	Case Style (Pages 260 - 267)	Approx. Dimensions (Inches)			Approx. Weight (Lbs.)	Mtg Type W - Wall F - Floor	Wiring Diagram (Pages 276 - 288)
			Width	Depth	Height			
15	NMT20K015PBS	NH6	23.90	25.00	28.75	275	F or W *	SCD 9
30	NMT20K030PBS	NH6	23.90	25.00	28.75	365	F or W *	SCD 9
45	NMT20K045PBS	NH3	26.00	25.00	38.00	565	F or W *	SCD 9
75	NMT20K075PBS	NH3	26.00	25.00	38.00	730	F or W *	SCD 9
112.5	NMT20K112PBS	NH4	32.00	29.50	41.00	950	F	SCD 9
150	NMT20K150PBS	NH4	32.00	29.50	41.00	1400	F	SCD 9
225	NMT20K225PBS	NJ1	39.50	34.00	51.50	1900	F	SCD 9
300	NMT20K300PBS	NJ2	48.50	38.40	59.00	2400	F	SCD 10
500	NMT20K500PBS	NJ3	51.50	43.40	66.00	3600	F	SCD 10
750	NMT20K750PBS			CONSULT FACTORY				

*WALL MOUNTING KIT AND/OR DRIP PLATE KIT REQUIRED. REFER TO PAGES 271 TO 273 FOR DETAILS.

COPPER WOUND, SHIELDED, THREE PHASE K-FACTOR 20

480 Delta Primary Volts

208Y/120 Secondary Volts

60 Hz

May be used on a 4 wire 480Y/277 Volt Supply

kVA	Catalog Number	Case Style (Pages 260 - 267)	Approx. Dimensions (Inches)			Approx. Weight (Lbs.)	Mtg Type W - Wall F - Floor	Wiring Diagram (Pages 276 - 288)
			Width	Depth	Height			
15	NMT20K015KBKF	NH6	23.90	25.00	28.75	275	F or W *	SCD 19
30	NMT20K030KBK	NH6	23.90	25.00	28.75	440	F or W *	SCD 19
45	NMT20K045KBK	NH3	26.00	25.00	38.00	700	F or W *	SCD 19
75	NMT20K075KBK	NH3	26.00	25.00	38.00	860	F or W *	SCD 19
112.5	NMT20K112KBK	NH4	32.00	29.50	41.00	1150	F	SCD 19
150	NMT20K150KBK	NH4	32.00	29.50	41.00	1600	F	SCD 19
225	NMT20K225KBK	NJ1	39.50	34.00	51.50	2100	F	SCD 19
300	NMT20K300KBK	NJ2	48.50	38.40	59.00	2600	F	SCD 20
500	NMT20K500KBK	NJ3	51.50	43.40	66.00	3800	F	SCD 20
750	NMT20K750KBK			CONSULT FACTORY				

*WALL MOUNTING KIT AND/OR DRIP PLATE KIT REQUIRED. REFER TO PAGES 271 TO 273 FOR DETAILS.

600 Delta Primary Volts

208Y/120 Secondary Volts

60 Hz

May be used on a 4 wire 600Y/347 Volt Supply

kVA	Catalog Number	Case Style (Pages 260 - 267)	Approx. Dimensions (Inches)			Approx. Weight (Lbs.)	Mtg Type W - Wall F - Floor	Wiring Diagram (Pages 276 - 288)
			Width	Depth	Height			
15	NMT20K015PBKF	NH6	23.90	25.00	28.75	275	F or W *	SCD 9
30	NMT20K030PBKN	NH6	23.90	25.00	28.75	440	F or W *	SCD 9
45	NMT20K045PBK	NH3	26.00	25.00	38.00	700	F or W *	SCD 9
75	NMT20K075PBK	NH3	26.00	25.00	38.00	860	F or W *	SCD 9
112.5	NMT20K112PBK	NH4	32.00	29.50	41.00	1150	F	SCD 9
150	NMT20K150PBK	NH4	32.00	29.50	41.00	1600	F	SCD 9
225	NMT20K225PBK	NJ1	39.50	34.00	51.50	2100	F	SCD 9
300	NMT20K300PBK	NJ2	48.50	38.40	59.00	2600	F	SCD 10
500	NMT20K500PBK	NJ3	51.50	43.40	66.00	3800	F	SCD 10
750	NMT20K750PBK			CONSULT FACTORY				

*WALL MOUNTING KIT AND/OR DRIP PLATE KIT REQUIRED. REFER TO PAGES 271 TO 273 FOR DETAILS.

Products listed on this page are available as 'CE Mark' products. Please consult our sales office.

FOR TERMINATION DETAILS SEE PAGE 275.

FOR ACCESSORIES SEE PAGES 271 TO 274.





HPS SUPERSYNERGY®

600 VOLT CLASS ENERGY EFFICIENT K-FACTOR TRANSFORMERS

K-Factor Transformer Efficiencies:

HPS SUPERSYNERGY (PART NUMBER PREFIX SMT)

The HPS SuperSynergy energy efficient k-factor transformer exceeds DOE 10 CFR Part 431/C802.2 efficiencies over a range of linear loads. It will not only satisfy the necessity for running at k-factor modern building load types, but in addition, because of the increasing need for energy conservation, they are much more efficient than that of our standard energy efficient line.

- Efficiency performance will meet the **NEMA Premium®** guidelines; **30% lower losses** than DOE 10 CFR Part 431 and (if applicable) C802.2 efficiency standards; when measured under a linear load profile at **35%** of rated load.
- Efficiency will meet or exceed DOE 10 CFR Part 431 and (if applicable) C802.2 standards; for linear load even at **50%** of rated load when measured under a **non-linear** load up to **K13**.
- Copper and Aluminum Available.



HPS SUPERSYNERGY® 600V CLASS SUPER ENERGY EFFICIENT K-FACTOR TRANSFORMERS



THREE PHASE STANDARD SPECIFICATIONS

15 TO 45 KVA

75 TO 750 KVA



THREE PHASE SPECIFICATIONS

NEMA 3R

	15 to 45 kVA	75 to 750 kVA
Efficiency	Efficiency performance will meet the NEMA Premium® guidelines; 30% lower losses than DOE 10 CFR Part 431 and (if applicable) C802.2 efficiency standards; when measured under a linear load profile at 35% of the rated load. Efficiency will meet or exceed DOE 10 CFR Part 431 and (if applicable) C802.2 efficiency standards; for linear loads even at 50% of rated load when measured under a non-linear load up to K13 .	
UL Listed	File: E112313	File: E112313
CSA Certified	File: LR3902	File: LR3902
Frequency	60 Hz	60 Hz
Insulation System	220°C (150°C rise) 200°C (130°C rise) on 15 & 30kVA copper (optional 115°C and 80°C rise available)	220°C (150°C rise) (optional 115°C and 80°C rise available)
Electrostatic Shield	60dB Common Mode - typical	60dB Common Mode - typical
Enclosure Type	Heavy Duty Ventilated Type 3R Optional Type 4, 4X (stainless steel) and 12.	Heavy Duty Ventilated Type 3R Optional Type 4, 4X (stainless steel) and 12.
Enclosure Finish	ANSI 61 Grey, UL50	ANSI 61 Grey, UL50
Neutral	Neutral terminal for field connection (on applicable units).	Neutral terminal for field connection (on applicable units).
Standard Primary Taps	Refer to wiring diagrams for details.	Refer to wiring diagrams for details.
Termination	Front accessible separate high and low voltage terminals; connectors suitable for aluminum and copper are provided for easy cable installation.	Front accessible separate high and low voltage terminals; connectors suitable for aluminum and copper are provided for easy cable installation.
Conduit Knock-Outs	Standard on all units.	Standard on 75 kVA & 150 kVA units.
Impedance	Typically 2.5% to 6.5%	Typically 2.5% to 6.5%
Mounting	Floor or wall/ceiling mounting available. Refer to selection tables for details.	Floor or wall/ceiling mounting available. Refer to selection tables for details.
Seismic	Meets Occupancy Category III $I_p=1.25$ for $S_s=1.0g$ per IBC 2006; section 1613, earthquake loads and NBCC 2005 for ground level installations only for all locations in North America.	Meets Occupancy Category III $I_p=1.25$ for $S_s=1.0g$ per IBC 2006; section 1613, earthquake loads and NBCC 2005 for ground level installations only for all locations in North America.
Sound level	Meets NEMA ST-20 standards. (Optional low noise units available)	Meets NEMA ST-20 standards. (Optional low noise units available)

* Optional TVSS available. Dual Output option also available. Features as listed above may differ. Contact sales for more details.

FOR TERMINATION DETAILS SEE PAGE 275.

FOR ACCESSORIES SEE PAGES 271 TO 274.



ALUMINUM WOUND, SHIELDED, THREE PHASE



K-FACTOR 13

208 Delta Primary Volts

208Y/120 Secondary Volts

60 Hz

kVA	Catalog Number	Case Style (Pages 260 - 267)	Approx. Dimensions (Inches)			Approx. Weight (Lbs.)	Mtg Type W - Wall F - Floor	Wiring Diagram (Pages 276 - 288)
			Width	Depth	Height			
15	Only available in copper. Please see SMT13K015BBKN on page 200 for details.							
30	SMT13K030BBS	NH6	23.90	25.00	28.75	350	F or W *	SCD 19
45	SMT13K045BBS	NH3	26.00	25.00	38.00	460	F or W *	SCD 19
75	SMT13K075BBS	NH4	32.00	29.50	41.00	650	F	SCD 19
112.5	SMT13K112BBS	NH4	32.00	29.50	41.00	960	F	SCD 19
150	SMT13K150BBS	NH4	32.00	29.50	41.00	1210	F	SCD 19
225	SMT13K225BBS	NJ1	39.50	34.00	51.50	1970	F	SCD 19
300	SMT13K300BBS	NJ2	48.50	38.40	59.00	2590	F	SCD 20
500	SMT13K500BBS	NJ3	51.50	43.40	66.00	4460	F	SCD 20
750	SMT13K750BBS	NJ6	64.00	51.40	71.00	6260	F	SCD 20

*WALL MOUNTING KIT AND/OR DRIP PLATE KIT REQUIRED. REFER TO PAGES 271 TO 273 FOR DETAILS.

208 Delta Primary Volts

480Y/277 Secondary Volts

60 Hz

kVA	Catalog Number	Case Style (Pages 260 - 267)	Approx. Dimensions (Inches)			Approx. Weight (Lbs.)	Mtg Type W - Wall F - Floor	Wiring Diagram (Pages 276 - 288)
			Width	Depth	Height			
15	Only available in copper. Please see SMT13K015BKKN on page 200 for details.							
30	SMT13K030BKS	NH6	23.90	25.00	28.75	350	F or W *	SCD 19
45	SMT13K045BKS	NH3	26.00	25.00	38.00	460	F or W *	SCD 19
75	SMT13K075BKS	NH4	32.00	29.50	41.00	650	F	SCD 19
112.5	SMT13K112BKS	NH4	32.00	29.50	41.00	960	F	SCD 19
150	SMT13K150BKS	NH4	32.00	29.50	41.00	1210	F	SCD 19
225	SMT13K225BKS	NJ1	39.50	34.00	51.50	1970	F	SCD 19
300	SMT13K300BKS	NJ2	48.50	38.40	59.00	2590	F	SCD 20
500	SMT13K500BKS	NJ3	51.50	43.40	66.00	4460	F	SCD 20
750	SMT13K750BKS	NJ6	64.00	51.40	71.00	6260	F	SCD 20

*WALL MOUNTING KIT AND/OR DRIP PLATE KIT REQUIRED. REFER TO PAGES 271 TO 273 FOR DETAILS.

480 Delta Primary Volts

208Y/120 Secondary Volts

60 Hz

May be used on a 4 wire 480Y/277 Volt Supply

kVA	Catalog Number	Case Style (Pages 260 - 267)	Approx. Dimensions (Inches)			Approx. Weight (Lbs.)	Mtg Type W - Wall F - Floor	Wiring Diagram (Pages 276 - 288)
			Width	Depth	Height			
15	Only available in copper. Please see SMT13K015KBKN on page 200 for details.							
30	SMT13K030KBS	NH6	23.90	25.00	28.75	350	F or W *	SCD 19
45	SMT13K045KBS	NH3	26.00	25.00	38.00	460	F or W *	SCD 19
75	SMT13K075KBS	NH4	32.00	29.50	41.00	650	F	SCD 19
112.5	SMT13K112KBS	NH4	32.00	29.50	41.00	960	F	SCD 19
150	SMT13K150KBS	NH4	32.00	29.50	41.00	1210	F	SCD 19
225	SMT13K225KBS	NJ1	39.50	34.00	51.50	1970	F	SCD 19
300	SMT13K300KBS	NJ2	48.50	38.40	59.00	2590	F	SCD 20
500	SMT13K500KBS	NJ3	51.50	43.40	66.00	4460	F	SCD 20
750	SMT13K750KBS	NJ6	64.00	51.40	71.00	6260	F	SCD 20

*WALL MOUNTING KIT AND/OR DRIP PLATE KIT REQUIRED. REFER TO PAGES 271 TO 273 FOR DETAILS.



ALUMINUM WOUND, SHIELDED, THREE PHASE K-FACTOR 13



480 Delta Primary Volts

480Y/277 Secondary Volts

60 Hz

May be used on a 4 wire 480Y/277 Volt Supply

kVA	Catalog Number	Case Style (Pages 260 - 267)	Approx. Dimensions (Inches)			Approx. Weight (Lbs.)	Mtg Type W - Wall F - Floor	Wiring Diagram (Pages 276 - 288)
			Width	Depth	Height			
15	Only available in copper. Please see SMT13K015KKKN on page 201 for details.							
30	SMT13K030KKS	NH6	23.90	25.00	28.75	350	F or W *	SCD 19
45	SMT13K045KKS	NH3	26.00	25.00	38.00	460	F or W *	SCD 19
75	SMT13K075KKS	NH4	32.00	29.50	41.00	650	F	SCD 19
112.5	SMT13K112KKS	NH4	32.00	29.50	41.00	960	F	SCD 19
150	SMT13K150KKS	NH4	32.00	29.50	41.00	1210	F	SCD 19
225	SMT13K225KKS	NJ1	39.50	34.00	51.50	1970	F	SCD 19
300	SMT13K300KKS	NJ2	48.50	38.40	59.00	2590	F	SCD 20
500	SMT13K500KKS	NJ3	51.50	43.40	66.00	4460	F	SCD 20
750	SMT13K750KKS	NJ6	64.00	51.40	71.00	6260	F	SCD 20

*WALL MOUNTING KIT AND/OR DRIP PLATE KIT REQUIRED. REFER TO PAGES 271 TO 273 FOR DETAILS.

600 Delta Primary Volts

208Y/120 Secondary Volts

60 Hz

May be used on a 4 wire 600Y/347 Volt Supply

kVA	Catalog Number	Case Style (Pages 260 - 267)	Approx. Dimensions (Inches)			Approx. Weight (Lbs.)	Mtg Type W - Wall F - Floor	Wiring Diagram (Pages 276 - 288)
			Width	Depth	Height			
15	Only available in copper. Please see SMT13K015PBKN on page 201 for details.							
30	SMT13K030PBS	NH6	23.90	25.00	28.75	350	F or W *	SCD 9
45	SMT13K045PBS	NH3	26.00	25.00	38.00	460	F or W *	SCD 9
75	SMT13K075PBS	NH4	32.00	29.50	41.00	650	F	SCD 9
112.5	SMT13K112PBS	NH4	32.00	29.50	41.00	960	F	SCD 9
150	SMT13K150PBS	NH4	32.00	29.50	41.00	1210	F	SCD 9
225	SMT13K225PBS	NJ1	39.50	34.00	51.50	1970	F	SCD 9
300	SMT13K300PBS	NJ2	48.50	38.40	59.00	2590	F	SCD 10
500	SMT13K500PBS	NJ3	51.50	43.40	66.00	4460	F	SCD 10
750	SMT13K750PBS	NJ6	64.00	51.40	71.00	6260	F	SCD 10

*WALL MOUNTING KIT AND/OR DRIP PLATE KIT REQUIRED. REFER TO PAGES 271 TO 273 FOR DETAILS.

600 Delta Primary Volts

480Y/277 Secondary Volts

60 Hz

May be used on a 4 wire 600Y/347 Volt Supply

kVA	Catalog Number	Case Style (Pages 260 - 267)	Approx. Dimensions (Inches)			Approx. Weight (Lbs.)	Mtg Type W - Wall F - Floor	Wiring Diagram (Pages 276 - 288)
			Width	Depth	Height			
15	Only available in copper. Please see SMT13K015PKKN on page 201 for details.							
30	SMT13K030PKS	NH6	23.90	25.00	28.75	350	F or W *	SCD 9
45	SMT13K045PKS	NH3	26.00	25.00	38.00	460	F or W *	SCD 9
75	SMT13K075PKS	NH4	32.00	29.50	41.00	650	F	SCD 9
112.5	SMT13K112PKS	NH4	32.00	29.50	41.00	960	F	SCD 9
150	SMT13K150PKS	NH4	32.00	29.50	41.00	1210	F	SCD 9
225	SMT13K225PKS	NJ1	39.50	34.00	51.50	1970	F	SCD 9
300	SMT13K300PKS	NJ2	48.50	38.40	59.00	2590	F	SCD 10
500	SMT13K500PKS	NJ3	51.50	43.40	66.00	4460	F	SCD 10
750	SMT13K750PKS	NJ6	64.00	51.40	71.00	6260	F	SCD 10

*WALL MOUNTING KIT AND/OR DRIP PLATE KIT REQUIRED. REFER TO PAGES 271 TO 273 FOR DETAILS.



FOR TERMINATION DETAILS SEE PAGE 275.

FOR ACCESSORIES SEE PAGES 271 TO 274.



COPPER WOUND, SHIELDED, THREE PHASE



K-FACTOR 13

208 Delta Primary Volts

208Y/120 Secondary Volts

60 Hz

kVA	Catalog Number	Case Style (Pages 260 - 267)	Approx. Dimensions (Inches)			Approx. Weight (Lbs.)	Mtg Type W - Wall F - Floor	Wiring Diagram (Pages 276 - 288)
			Width	Depth	Height			
15	SMT13K015BBKN	NH5	19.40	20.20	21.50	250	F or W *	SCD 19
30	SMT13K030BBKN	NH6	23.90	25.00	28.75	390	F or W *	SCD 19
45	SMT13K045BBK	NH6	23.90	25.00	28.75	460	F or W *	SCD 19
75	SMT13K075BBK	NH3	26.00	25.00	38.00	660	F or W *	SCD 19
112.5	SMT13K112BBK	NH4	32.00	29.50	41.00	1000	F	SCD 19
150	SMT13K150BBK	NH4	32.00	29.50	41.00	1250	F	SCD 19
225	SMT13K225BBK	NJ1	39.50	34.00	51.50	1960	F	SCD 19
300	SMT13K300BBK	NJ2	48.50	38.40	59.00	2470	F	SCD 20
500	SMT13K500BBK	NJ3	51.50	43.40	66.00	3930	F	SCD 20
750	SMT13K750BBK	NJ6	64.00	57.40	71.00	5750	F	SCD20

*WALL MOUNTING KIT AND/OR DRIP PLATE KIT REQUIRED. REFER TO PAGES 271 TO 273 FOR DETAILS.

208 Delta Primary Volts

480Y/277 Secondary Volts

60 Hz

kVA	Catalog Number	Case Style (Pages 260 - 267)	Approx. Dimensions (Inches)			Approx. Weight (Lbs.)	Mtg Type W - Wall F - Floor	Wiring Diagram (Pages 276 - 288)
			Width	Depth	Height			
15	SMT13K015BKK	NH5	19.40	20.20	21.50	250	F or W *	SCD 19
30	SMT13K030BKK	NH6	23.90	25.00	28.75	390	F or W *	SCD 19
45	SMT13K045BKK	NH6	23.90	25.00	28.75	460	F or W *	SCD 19
75	SMT13K075BKK	NH3	26.00	25.00	38.00	660	F or W *	SCD 19
112.5	SMT13K112BKK	NH4	32.00	29.50	41.00	1000	F	SCD 19
150	SMT13K150BKK	NH4	32.00	29.50	41.00	1250	F	SCD 19
225	SMT13K225BKK	NJ1	39.50	34.00	51.50	1960	F	SCD 19
300	SMT13K300BKK	NJ2	48.50	38.40	59.00	2470	F	SCD 20
500	SMT13K500BKK	NJ3	51.50	43.40	66.00	3930	F	SCD 20
750	SMT13K750BKK	NJ6	64.00	57.40	71.00	5750	F	SCD20

*WALL MOUNTING KIT AND/OR DRIP PLATE KIT REQUIRED. REFER TO PAGES 271 TO 273 FOR DETAILS.

480 Delta Primary Volts

208Y/120 Secondary Volts

60 Hz

May be used on a 4 wire 480Y/277 Volt Supply

kVA	Catalog Number	Case Style (Pages 260 - 267)	Approx. Dimensions (Inches)			Approx. Weight (Lbs.)	Mtg Type W - Wall F - Floor	Wiring Diagram (Pages 276 - 288)
			Width	Depth	Height			
15	SMT13K015KBKN	NH5	19.40	20.20	21.50	250	F or W *	SCD 19
30	SMT13K030KBKN	NH6	23.90	25.00	28.75	390	F or W *	SCD 19
45	SMT13K045KBK	NH6	23.90	25.00	28.75	460	F or W *	SCD 19
75	SMT13K075KBK	NH3	26.00	25.00	38.00	660	F or W *	SCD 19
112.5	SMT13K112KBK	NH4	32.00	29.50	41.00	1000	F	SCD 19
150	SMT13K150KBK	NH4	32.00	29.50	41.00	1250	F	SCD 19
225	SMT13K225KBK	NJ1	39.50	34.00	51.50	1960	F	SCD 19
300	SMT13K300KBK	NJ2	48.50	38.40	59.00	2470	F	SCD 20
500	SMT13K500KBK	NJ3	51.50	43.40	66.00	3930	F	SCD 20
750	SMT13K750KBK	NJ6	64.00	57.40	71.00	5750	F	SCD20

*WALL MOUNTING KIT AND/OR DRIP PLATE KIT REQUIRED. REFER TO PAGES 271 TO 273 FOR DETAILS.



COPPER WOUND, SHIELDED, THREE PHASE



K-FACTOR 13

480 Delta Primary Volts

480Y/277 Secondary Volts

60 Hz

May be used on a 4 wire 480Y/277 Volt Supply

kVA	Catalog Number	Case Style (Pages 260 - 267)	Approx. Dimensions (Inches)			Approx. Weight (Lbs.)	Mtg Type W - Wall F - Floor	Wiring Diagram (Pages 276 - 288)
			Width	Depth	Height			
15	SMT13K015KKN	NH5	19.40	20.20	21.50	250	F or W *	SCD 19
30	SMT13K030KKN	NH6	23.90	25.00	28.75	390	F or W *	SCD 19
45	SMT13K045KKN	NH6	23.90	25.00	28.75	460	F or W *	SCD 19
75	SMT13K075KKN	NH3	26.00	25.00	38.00	660	F or W *	SCD 19
112.5	SMT13K112KKN	NH4	32.00	29.50	41.00	1000	F	SCD 19
150	SMT13K150KKN	NH4	32.00	29.50	41.00	1250	F	SCD 19
225	SMT13K225KKN	NJ1	39.50	34.00	51.50	1960	F	SCD 19
300	SMT13K300KKN	NJ2	48.50	38.40	59.00	2470	F	SCD 20
500	SMT13K500KKN	NJ3	51.50	43.40	66.00	3930	F	SCD 20
750	SMT13K750KKN	NJ6	64.00	57.40	71.00	5750	F	SCD20

*WALL MOUNTING KIT AND/OR DRIP PLATE KIT REQUIRED. REFER TO PAGES 271 TO 273 FOR DETAILS.

600 Delta Primary Volts

208Y/120 Secondary Volts

60 Hz

May be used on a 4 wire 600Y/347 Volt Supply

kVA	Catalog Number	Case Style (Pages 260 - 267)	Approx. Dimensions (Inches)			Approx. Weight (Lbs.)	Mtg Type W - Wall F - Floor	Wiring Diagram (Pages 276 - 288)
			Width	Depth	Height			
15	SMT13K015PBKN	NH5	19.40	20.20	21.50	250	F or W *	SCD 19
30	SMT13K030PBKN	NH6	23.90	25.00	28.75	390	F or W *	SCD 19
45	SMT13K045PBKN	NH6	23.90	25.00	28.75	460	F or W *	SCD 19
75	SMT13K075PBKN	NH3	26.00	25.00	38.00	660	F or W *	SCD 19
112.5	SMT13K112PBKN	NH4	32.00	29.50	41.00	1000	F	SCD 19
150	SMT13K150PBKN	NH4	32.00	29.50	41.00	1250	F	SCD 19
225	SMT13K225PBKN	NJ1	39.50	34.00	51.50	1960	F	SCD 19
300	SMT13K300PBKN	NJ2	48.50	38.40	59.00	2470	F	SCD 20
500	SMT13K500PBKN	NJ3	51.50	43.40	66.00	3930	F	SCD 20
750	SMT13K750PBKN	NJ6	64.00	57.40	71.00	5750	F	SCD20

*WALL MOUNTING KIT AND/OR DRIP PLATE KIT REQUIRED. REFER TO PAGES 271 TO 273 FOR DETAILS.

600 Delta Primary Volts

480Y/277 Secondary Volts

60 Hz

May be used on a 4 wire 600Y/347 Volt Supply

kVA	Catalog Number	Case Style (Pages 260 - 267)	Approx. Dimensions (Inches)			Approx. Weight (Lbs.)	Mtg Type W - Wall F - Floor	Wiring Diagram (Pages 276 - 288)
			Width	Depth	Height			
15	SMT13K015PKKN	NH5	19.40	20.20	21.50	250	F or W *	SCD 19
30	SMT13K030PKKN	NH6	23.90	25.00	28.75	390	F or W *	SCD 19
45	SMT13K045PKKN	NH6	23.90	25.00	28.75	460	F or W *	SCD 19
75	SMT13K075PKKN	NH3	26.00	25.00	38.00	660	F or W *	SCD 19
112.5	SMT13K112PKKN	NH4	32.00	29.50	41.00	1000	F	SCD 19
150	SMT13K150PKKN	NH4	32.00	29.50	41.00	1250	F	SCD 19
225	SMT13K225PKKN	NJ1	39.50	34.00	51.50	1960	F	SCD 19
300	SMT13K300PKKN	NJ2	48.50	38.40	59.00	2470	F	SCD 20
500	SMT13K500PKKN	NJ3	51.50	43.40	66.00	3930	F	SCD 20
750	SMT13K750PKKN	NJ6	64.00	57.40	71.00	5750	F	SCD20

*WALL MOUNTING KIT AND/OR DRIP PLATE KIT REQUIRED. REFER TO PAGES 271 TO 273 FOR DETAILS.



FOR TERMINATION DETAILS SEE PAGE 275.

FOR ACCESSORIES SEE PAGES 271 TO 274.



HPS CENTURION® Series

600V CLASS HARMONIC MITIGATING TRANSFORMERS

The HPS Centurion Energy Efficient, Harmonic Mitigating Transformers with zero sequence flux cancellation technology is specifically designed to treat the harmonics generated by computer equipment and other non-linear, power electronic loads.

Harmonic mitigating transformers are superior to K-Rated and conventional transformers in reducing voltage distortion (flat-topping) and power losses due to current harmonics created by single-phase, non-linear loads such as computer equipment. Secondary windings are designed to cancel zero sequence fluxes and eliminate primary winding circulating currents. They treat zero sequence harmonics (3rd, 9th and 15th) within the secondary windings and 5th and 7th harmonics upstream with an appropriate phase shift.



Dual Output Option

Dual output, phase shifting HMT provides extremely low output voltage distortion and input current distortion even under severe non-linear loading conditions (Data Centers, Internet Service Providers, Telecom Sites, Broadcasting Studios, etc). Combining zero sequence flux cancellation with phase shifting treats 3rd, 5th, 7th, 9th, 15th, 17th and 19th harmonics within its secondary windings.

HPS Centurion Series Harmonic Mitigating Transformer:

- Prevents voltage flat-topping caused by non-linear loads
- Reduces upstream harmonic currents
- Eliminates transformer overheating and high operating temperatures
- Eliminates primary winding circulating current
- Saves energy by reducing harmonic losses
- Maintains high energy efficiency even under non-linear loading conditions
- Electrostatic shielding for high frequency noise attenuation
- Lowers voltage distortion to prevent premature equipment failure
- Restores ride-through capability of computer equipment
- Treats power quality harmonic issues which K-rated transformers do not address
- Suitable for high K-factor loads
- Reduces current distortion at UPS, generator or Utility service
- Improves Upstream Total Power Factor

HPS CENTURION[®]

600 VOLT CLASS ENERGY EFFICIENT HARMONIC MITIGATING TRANSFORMERS

Harmonic Mitigating Transformer Efficiencies:

The HPS Centurion energy efficient, harmonic mitigating transformer with zero sequence flux cancellation technology is specifically designed to treat the harmonics generated by computer equipment and other non-linear, power electronic loads.

Combining zero sequence flux cancellation with phase shifting treats 3rd, 5th, 7th, 9th, 15th, 17th and 19th, harmonics within its secondary windings. Typical applications of severe non-linear loading conditions include data centers, internet-service providers, telecom sites, call centers, broadcast centers, etc.

HPS CENTURION (PART NUMBER PREFIX H1EM OR H2EM)

- Meets **DOE 10 CFR Part 431 and C802.2** efficiencies at an operating range from **35% to 65%** of rated linear load.
- Meets **DOE 10 CFR Part 431 and C802.2** efficiency standards when measured under a **non-linear** load profile up to **K20** in an operating range from **35% to 50%**.
- Copper & Aluminum Available.



HPS Centurion®

600V CLASS ENERGY EFFICIENT HARMONIC MITIGATING TRANSFORMERS

THREE PHASE STANDARD SPECIFICATIONS



15 to 45 kVA



75 TO 750 KVA



THREE PHASE SPECIFICATIONS

NEMA 3R

	15 to 45 kVA	75 to 750 kVA
Efficiency	Meets DOE 10 CFR Part 431 and C802.2 efficiencies at an operating range from 35% to 65% of rated linear load. Meets DOE 10 CFR Part 431 and C802.2 efficiency standards when measured under a non-linear load profile up to K20 in an operating range from 35% to 50%.	
UL Listed	File: E112313	File: E112313
CSA Certified	File: LR3902	File: LR3902
Frequency	60 Hz	60 Hz
Insulation System	220°C (150°C rise) 200°C (130°C rise) on 15 & 30kVA copper (optional 115°C and 80°C rise available)	220°C (150°C rise) (optional 115°C and 80°C rise available)
Electrostatic Shield	60dB Common Mode - typical	60dB Common Mode - typical
Enclosure Type	Heavy Duty Ventilated Type 3R Optional Type 4, 4X (stainless steel) and 12.	Heavy Duty Ventilated Type 3R Optional Type 4, 4X (stainless steel) and 12.
Enclosure Finish	ANSI 61 Grey, UL50	ANSI 61 Grey, UL50
Neutral	Neutral terminal for field connection (on applicable units).	Neutral terminal for field connection (on applicable units).
Standard Primary Taps	Refer to wiring diagrams for details.	Refer to wiring diagrams for details.
Termination	Front accessible separate high and low voltage terminals; connectors suitable for aluminum and copper are provided for easy cable installation.	Front accessible separate high and low voltage terminals; connectors suitable for aluminum and copper are provided for easy cable installation.
Conduit Knock-Outs	Standard on all units.	Standard on 75 kVA & 150 kVA units.
Impedance	Typically 2.5% to 6.5%	Typically 2.5% to 6.5%
Mounting	Floor or wall/ceiling mounting available. Refer to selection tables for details.	Floor or wall/ceiling mounting available. Refer to selection tables for details.
Seismic	Meets Occupancy Category III Ip=1.25 for Ss=1.0g per IBC 2006; section 1613, earthquake loads and NBCC 2005 for ground level installations only for all locations in North America.	Meets Occupancy Category III Ip=1.25 for Ss=1.0g per IBC 2006; section 1613, earthquake loads and NBCC 2005 for ground level installations only for all locations in North America.
Sound level	Meets NEMA ST-20 standards. (Optional low noise units available)	Meets NEMA ST-20 standards. (Optional low noise units available)

* Optional TVSS available. Dual Output option also available. Features as listed above may differ. Contact sales for more details.

FOR TERMINATION DETAILS SEE PAGE 275.

FOR ACCESSORIES SEE PAGES 271 TO 274.

SECTION 7



ALUMINUM WOUND, THREE PHASE, SHIELDED 0° PHASE SHIFT



208 Delta Primary Volts

208Y/120 Secondary Volts

60 Hz

kVA	Catalog Number	Case Style (Pages 260 - 267)	Approx. Dimensions (Inches)			Approx. Weight (Lbs.)	Mtg Type W - Wall F - Floor	Wiring Diagram (Pages 276 - 288)
			Width	Depth	Height			
15	H1EM015BB00S	NH5	19.40	20.20	21.50	220	F or W *	SCD 35
30	H1EM030BB00S	NH6	23.90	25.00	28.75	320	F or W *	SCD 35
45	H1EM045BB00S	NH6	23.90	25.00	28.75	430	F or W *	SCD 35
75	H1EM075BB00S	NH3	26.00	25.00	38.00	640	F or W *	SCD 35
112.5	H1EM112BB00S	NH4	32.00	29.50	41.00	920	F	SCD 35
150	H1EM150BB00S	NH4	32.00	29.50	41.00	1100	F	SCD 35
225	H1EM225BB00S	NJ1	39.50	34.00	51.50	1575	F	SCD 35
300	H1EM300BB00S	NJ2	48.50	38.40	59.00	1830	F	SCD 35
500	H1EM500BB00S	NJ3	51.50	43.40	66.00	2700	F	SCD 35
750	H1EM750BB00S	NJ3	51.50	43.40	66.00	3800	F	SCD 35

*WALL MOUNTING KIT AND/OR DRIP PLATE KIT REQUIRED.
REFER TO PAGES 271 TO 273 FOR DETAILS.

208 Delta Primary Volts

480Y/277 Secondary Volts

60 Hz

kVA	Catalog Number	Case Style (Pages 260 - 267)	Approx. Dimensions (Inches)			Approx. Weight (Lbs.)	Mtg Type W - Wall F - Floor	Wiring Diagram (Pages 276 - 288)
			Width	Depth	Height			
15	H1EM015BK00S	NH5	19.40	20.20	21.50	220	F or W *	SCD 35
30	H1EM030BK00S	NH6	23.90	25.00	28.75	320	F or W *	SCD 35
45	H1EM045BK00S	NH6	23.90	25.00	28.75	430	F or W *	SCD 35
75	H1EM075BK00S	NH3	26.00	25.00	38.00	640	F or W *	SCD 35
112.5	H1EM112BK00S	NH4	32.00	29.50	41.00	920	F	SCD 35
150	H1EM150BK00S	NH4	32.00	29.50	41.00	1100	F	SCD 35
225	H1EM225BK00S	NJ1	39.50	34.00	51.50	1575	F	SCD 35
300	H1EM300BK00S	NJ2	48.50	38.40	59.00	1830	F	SCD 35
500	H1EM500BK00S	NJ3	51.50	43.40	66.00	2700	F	SCD 35
750	H1EM750BK00S	NJ3	51.50	43.40	66.00	3800	F	SCD 35

*WALL MOUNTING KIT AND/OR DRIP PLATE KIT REQUIRED.
REFER TO PAGES 271 TO 273 FOR DETAILS.

480 Delta Primary Volts

208Y/120 Secondary Volts

60 Hz

kVA	Catalog Number	Case Style (Pages 260 - 267)	Approx. Dimensions (Inches)			Approx. Weight (Lbs.)	Mtg Type W - Wall F - Floor	Wiring Diagram (Pages 276 - 288)
			Width	Depth	Height			
15	H1EM015KB00S	NH5	19.40	20.20	21.50	220	F or W *	SCD 35
30	H1EM030KB00S	NH6	23.90	25.00	28.75	320	F or W *	SCD 35
45	H1EM045KB00S	NH6	23.90	25.00	28.75	430	F or W *	SCD 35
75	H1EM075KB00S	NH3	26.00	25.00	38.00	640	F or W *	SCD 35
112.5	H1EM112KB00S	NH4	32.00	29.50	41.00	920	F	SCD 35
150	H1EM150KB00S	NH4	32.00	29.50	41.00	1100	F	SCD 35
225	H1EM225KB00S	NJ1	39.50	34.00	51.50	1575	F	SCD 35
300	H1EM300KB00S	NJ2	48.50	38.40	59.00	1830	F	SCD 35
500	H1EM500KB00S	NJ3	51.50	43.40	66.00	2700	F	SCD 35
750	H1EM750KB00S	NJ3	51.50	43.40	66.00	3800	F	SCD 35

*WALL MOUNTING KIT AND/OR DRIP PLATE KIT REQUIRED.
REFER TO PAGES 271 TO 273 FOR DETAILS.





ALUMINUM WOUND, THREE PHASE, SHIELDED 0° PHASE SHIFT

480 Delta Primary Volts

480Y/277 Secondary Volts

60 Hz

kVA	Catalog Number	Case Style (Pages 260 - 267)	Approx. Dimensions (Inches)			Approx. Weight (Lbs.)	Mtg Type W - Wall F - Floor	Wiring Diagram (Pages 276 - 288)
			Width	Depth	Height			
15	H1EM015KK00S	NH5	19.40	20.20	21.50	220	F or W *	SCD 35
30	H1EM030KK00S	NH6	23.90	25.00	28.75	320	F or W *	SCD 35
45	H1EM045KK00S	NH6	23.90	25.00	28.75	430	F or W *	SCD 35
75	H1EM075KK00S	NH3	26.00	25.00	38.00	640	F or W *	SCD 35
112.5	H1EM112KK00S	NH4	32.00	29.50	41.00	920	F	SCD 35
150	H1EM150KK00S	NH4	32.00	29.50	41.00	1100	F	SCD 35
225	H1EM225KK00S	NJ1	39.50	34.00	51.50	1575	F	SCD 35
300	H1EM300KK00S	NJ2	48.50	38.40	59.00	1830	F	SCD 35
500	H1EM500KK00S	NJ3	51.50	43.40	66.00	2700	F	SCD 35
750	H1EM750KK00S	NJ3	51.50	43.40	66.00	3800	F	SCD 35

*WALL MOUNTING KIT AND/OR DRIP PLATE KIT REQUIRED.
REFER TO PAGES 271 TO 273 FOR DETAILS.

600 Delta Primary Volts

208Y/120 Secondary Volts

60 Hz

kVA	Catalog Number	Case Style (Pages 260 - 267)	Approx. Dimensions (Inches)			Approx. Weight (Lbs.)	Mtg Type W - Wall F - Floor	Wiring Diagram (Pages 276 - 288)
			Width	Depth	Height			
15	H1EM015PB00S	NH5	19.40	20.20	21.50	220	F or W *	SCD 35
30	H1EM030PB00S	NH6	23.90	25.00	28.75	320	F or W *	SCD 35
45	H1EM045PB00S	NH6	23.90	25.00	28.75	430	F or W *	SCD 35
75	H1EM075PB00S	NH3	26.00	25.00	38.00	640	F or W *	SCD 35
112.5	H1EM112PB00S	NH4	32.00	29.50	41.00	920	F	SCD 35
150	H1EM150PB00S	NH4	32.00	29.50	41.00	1100	F	SCD 35
225	H1EM225PB00S	NJ1	39.50	34.00	51.50	1575	F	SCD 35
300	H1EM300PB00S	NJ2	48.50	38.40	59.00	1830	F	SCD 35
500	H1EM500PB00S	NJ3	51.50	43.40	66.00	2700	F	SCD 35
750	H1EM750PB00S	NJ3	51.50	43.40	66.00	3800	F	SCD 35

*WALL MOUNTING KIT AND/OR DRIP PLATE KIT REQUIRED.
REFER TO PAGES 271 TO 273 FOR DETAILS.

600 Delta Primary Volts

480Y/277 Secondary Volts

60 Hz

kVA	Catalog Number	Case Style (Pages 260 - 267)	Approx. Dimensions (Inches)			Approx. Weight (Lbs.)	Mtg Type W - Wall F - Floor	Wiring Diagram (Pages 276 - 288)
			Width	Depth	Height			
15	H1EM015PK00S	NH5	19.40	20.20	21.50	220	F or W *	SCD 35
30	H1EM030PK00S	NH6	23.90	25.00	28.75	320	F or W *	SCD 35
45	H1EM045PK00S	NH6	23.90	25.00	28.75	430	F or W *	SCD 35
75	H1EM075PK00S	NH3	26.00	25.00	38.00	640	F or W *	SCD 35
112.5	H1EM112PK00S	NH4	32.00	29.50	41.00	920	F	SCD 35
150	H1EM150PK00S	NH4	32.00	29.50	41.00	1100	F	SCD 35
225	H1EM225PK00S	NJ1	39.50	34.00	51.50	1575	F	SCD 35
300	H1EM300PK00S	NJ2	48.50	38.40	59.00	1830	F	SCD 35
500	H1EM500PK00S	NJ3	51.50	43.40	66.00	2700	F	SCD 35
750	H1EM750PB00S	NJ3	51.50	43.40	66.00	3800	F	SCD 35

*WALL MOUNTING KIT AND/OR DRIP PLATE KIT REQUIRED.
REFER TO PAGES 271 TO 273 FOR DETAILS.





ALUMINUM WOUND, THREE PHASE, SHIELDED -30° PHASE SHIFT

208 Wye Primary Volts

208Y/120 Secondary Volts

60 Hz

kVA	Catalog Number	Case Style (Pages 260 - 267)	Approx. Dimensions (Inches)			Approx. Weight (Lbs.)	Mtg Type W - Wall F - Floor	Wiring Diagram (Pages 276 - 288)
			Width	Depth	Height			
15	H1EM015BB30S	NH5	19.40	20.20	21.50	220	F or W *	SCD 35
30	H1EM030BB30S	NH6	23.90	25.00	28.75	320	F or W *	SCD 35
45	H1EM045BB30S	NH6	23.90	25.00	28.75	430	F or W *	SCD 35
75	H1EM075BB30S	NH3	26.00	25.00	38.00	640	F or W *	SCD 35
112.5	H1EM112BB30S	NH4	32.00	29.50	41.00	920	F	SCD 35
150	H1EM150BB30S	NH4	32.00	29.50	41.00	1100	F	SCD 35
225	H1EM225BB30S	NJ1	39.50	34.00	51.50	1575	F	SCD 35
300	H1EM300BB30S	NJ2	48.50	38.40	59.00	1830	F	SCD 35
500	H1EM500BB30S	NJ3	51.50	43.40	66.00	2700	F	SCD 35
750	H1EM750BB30S	NJ3	51.50	43.40	66.00	3800	F	SCD 35

*WALL MOUNTING KIT AND/OR DRIP PLATE KIT REQUIRED.
REFER TO PAGES 271 TO 273 FOR DETAILS.

208 Wye Primary Volts

480Y/277 Secondary Volts

60 Hz

kVA	Catalog Number	Case Style (Pages 260 - 267)	Approx. Dimensions (Inches)			Approx. Weight (Lbs.)	Mtg Type W - Wall F - Floor	Wiring Diagram (Pages 276 - 288)
			Width	Depth	Height			
15	H1EM015BK30S	NH5	19.40	20.20	21.50	220	F or W *	SCD 35
30	H1EM030BK30S	NH6	23.90	25.00	28.75	320	F or W *	SCD 35
45	H1EM045BK30S	NH6	23.90	25.00	28.75	430	F or W *	SCD 35
75	H1EM075BK30S	NH3	26.00	25.00	38.00	640	F or W *	SCD 35
112.5	H1EM112BK30S	NH4	32.00	29.50	41.00	920	F	SCD 35
150	H1EM150BK30S	NH4	32.00	29.50	41.00	1100	F	SCD 35
225	H1EM225BK30S	NJ1	39.50	34.00	51.50	1575	F	SCD 35
300	H1EM300BK30S	NJ2	48.50	38.40	59.00	1830	F	SCD 35
500	H1EM500BK30S	NJ3	51.50	43.40	66.00	3200	F	SCD 35
750	H1EM750BK30S	NJ3	51.50	43.40	66.00	3800	F	SCD 35

*WALL MOUNTING KIT AND/OR DRIP PLATE KIT REQUIRED.
REFER TO PAGES 271 TO 273 FOR DETAILS.

480 Wye Primary Volts

208Y/120 Secondary Volts

60 Hz

kVA	Catalog Number	Case Style (Pages 260 - 267)	Approx. Dimensions (Inches)			Approx. Weight (Lbs.)	Mtg Type W - Wall F - Floor	Wiring Diagram (Pages 276 - 288)
			Width	Depth	Height			
15	H1EM015KB30S	NH5	19.40	20.20	21.50	220	F or W *	SCD 35
30	H1EM030KB30S	NH6	23.90	25.00	28.75	320	F or W *	SCD 35
45	H1EM045KB30S	NH6	23.90	25.00	28.75	430	F or W *	SCD 35
75	H1EM075KB30S	NH3	26.00	25.00	38.00	640	F or W *	SCD 35
112.5	H1EM112KB30S	NH4	32.00	29.50	41.00	920	F	SCD 35
150	H1EM150KB30S	NH4	32.00	29.50	41.00	1100	F	SCD 35
225	H1EM225KB30S	NJ1	39.50	34.00	51.50	1575	F	SCD 35
300	H1EM300KB30S	NJ2	48.50	38.40	59.00	1830	F	SCD 35
500	H1EM500KB30S	NJ3	51.50	43.40	66.00	2700	F	SCD 35
750	H1EM750KB30S	NJ3	51.50	43.40	66.00	3800	F	SCD 35

*WALL MOUNTING KIT AND/OR DRIP PLATE KIT REQUIRED.
REFER TO PAGES 271 TO 273 FOR DETAILS.





ALUMINUM WOUND, THREE PHASE, SHIELDED -30° PHASE SHIFT

480 Wye Primary Volts

480Y/277 Secondary Volts

60 Hz

kVA	Catalog Number	Case Style (Pages 260 - 267)	Approx. Dimensions (Inches)			Approx. Weight (Lbs.)	Mtg Type W - Wall F - Floor	Wiring Diagram (Pages 276 - 288)
			Width	Depth	Height			
15	H1EM015KK30S	NH5	19.40	20.20	21.50	220	F or W *	SCD 35
30	H1EM030KK30S	NH6	23.90	25.00	28.75	320	F or W *	SCD 35
45	H1EM045KK30S	NH6	23.90	25.00	28.75	430	F or W *	SCD 35
75	H1EM075KK30S	NH3	26.00	25.00	38.00	640	F or W *	SCD 35
112.5	H1EM112KK30S	NH4	32.00	29.50	41.00	920	F	SCD 35
150	H1EM150KK30S	NH4	32.00	29.50	41.00	1100	F	SCD 35
225	H1EM225KK30S	NJ1	39.50	34.00	51.50	1575	F	SCD 35
300	H1EM300KK30S	NJ2	48.50	38.40	59.00	1830	F	SCD 35
500	H1EM500KK30S	NJ3	51.50	43.40	66.00	2700	F	SCD 35
750	H1EM750KK30S	NJ3	51.50	43.40	66.00	3800	F	SCD 35

*WALL MOUNTING KIT AND/OR DRIP PLATE KIT REQUIRED.
REFER TO PAGES 271 TO 273 FOR DETAILS.

600 Wye Primary Volts

208Y/120 Secondary Volts

60 Hz

kVA	Catalog Number	Case Style (Pages 260 - 267)	Approx. Dimensions (Inches)			Approx. Weight (Lbs.)	Mtg Type W - Wall F - Floor	Wiring Diagram (Pages 276 - 288)
			Width	Depth	Height			
15	H1EM015PB30S	NH5	19.40	20.20	21.50	220	F or W *	SCD 35
30	H1EM030PB30S	NH6	23.90	25.00	28.75	320	F or W *	SCD 35
45	H1EM045PB30S	NH6	23.90	25.00	28.75	430	F or W *	SCD 35
75	H1EM075PB30S	NH3	26.00	25.00	38.00	640	F or W *	SCD 35
112.5	H1EM112PB30S	NH4	32.00	29.50	41.00	920	F	SCD 35
150	H1EM150PB30S	NH4	32.00	29.50	41.00	1100	F	SCD 35
225	H1EM225PB30S	NJ1	39.50	34.00	51.50	1575	F	SCD 35
300	H1EM300PB30S	NJ2	48.50	38.40	59.00	1830	F	SCD 35
500	H1EM500PB30S	NJ3	51.50	43.40	66.00	2700	F	SCD 35
750	H1EM750PB30S	NJ3	51.50	43.40	66.00	3800	F	SCD 35

*WALL MOUNTING KIT AND/OR DRIP PLATE KIT REQUIRED.
REFER TO PAGES 271 TO 273 FOR DETAILS.

600 Wye Primary Volts

480Y/277 Secondary Volts

60 Hz

kVA	Catalog Number	Case Style (Pages 260 - 267)	Approx. Dimensions (Inches)			Approx. Weight (Lbs.)	Mtg Type W - Wall F - Floor	Wiring Diagram (Pages 276 - 288)
			Width	Depth	Height			
15	H1EM015PK30S	NH5	19.40	20.20	21.50	220	F or W *	SCD 35
30	H1EM030PK30S	NH6	23.90	25.00	28.75	320	F or W *	SCD 35
45	H1EM045PK30S	NH6	23.90	25.00	28.75	430	F or W *	SCD 35
75	H1EM075PK30S	NH3	26.00	25.00	38.00	640	F or W *	SCD 35
112.5	H1EM112PK30S	NH4	32.00	29.50	41.00	920	F	SCD 35
150	H1EM150PK30S	NH4	32.00	29.50	41.00	1100	F	SCD 35
225	H1EM225PK30S	NJ1	39.50	34.00	51.50	1575	F	SCD 35
300	H1EM300PK30S	NJ2	48.50	38.40	59.00	1830	F	SCD 35
500	H1EM500PK30S	NJ3	51.50	43.40	66.00	2700	F	SCD 35
750	H1EM500PK30S	NJ3	51.50	43.40	66.00	3800	F	SCD 35

*WALL MOUNTING KIT AND/OR DRIP PLATE KIT REQUIRED.
REFER TO PAGES 271 TO 273 FOR DETAILS.

SECTION 7





COPPER WOUND, THREE PHASE, SHIELDED 0° PHASE SHIFT

208 Delta Primary Volts

208Y/120 Secondary Volts

60 Hz

kVA	Catalog Number	Case Style (Pages 260 - 267)	Approx. Dimensions (Inches)			Approx. Weight (Lbs.)	Mtg Type W - Wall F - Floor	Wiring Diagram (Pages 276 - 288)
			Width	Depth	Height			
15	H1EM015BB00	NH5	19.40	20.20	21.50	240	F or W *	SCD 35
30	H1EM030BB00	NH6	23.90	25.00	28.75	360	F or W *	SCD 35
45	H1EM045BB00	NH6	23.90	25.00	28.75	465	F or W *	SCD 35
75	H1EM075BB00	NH3	26.00	25.00	38.00	740	F or W *	SCD 35
112.5	H1EM112BB00	NH4	32.00	29.50	41.00	1100	F	SCD 35
150	H1EM150BB00	NH4	32.00	29.50	41.00	1350	F	SCD 35
225	H1EM225BB00	NJ1	39.50	34.00	51.50	1800	F	SCD 35
300	H1EM300BB00	NJ2	48.50	38.40	59.00	2250	F	SCD 35
500	H1EM500BB00	NJ3	51.50	43.40	66.00	3000	F	SCD 35
750	H1EM750BB00	NJ3	51.50	43.40	66.00	4200	F	SCD 35

*WALL MOUNTING KIT AND/OR DRIP PLATE KIT REQUIRED.
REFER TO PAGES 271 TO 273 FOR DETAILS.

208 Delta Primary Volts

480Y/277 Secondary Volts

60 Hz

kVA	Catalog Number	Case Style (Pages 260 - 267)	Approx. Dimensions (Inches)			Approx. Weight (Lbs.)	Mtg Type W - Wall F - Floor	Wiring Diagram (Pages 276 - 288)
			Width	Depth	Height			
15	H1EM015BK00	NH5	19.40	20.20	21.50	240	F or W *	SCD 35
30	H1EM030BK00	NH6	23.90	25.00	28.75	360	F or W *	SCD 35
45	H1EM045BK00	NH6	23.90	25.00	28.75	465	F or W *	SCD 35
75	H1EM075BK00	NH3	26.00	25.00	38.00	740	F or W *	SCD 35
112.5	H1EM112BK00	NH4	32.00	29.50	41.00	1100	F	SCD 35
150	H1EM150BK00	NH4	32.00	29.50	41.00	1350	F	SCD 35
225	H1EM225BK00	NJ1	39.50	34.00	51.50	1800	F	SCD 35
300	H1EM300BK00	NJ2	48.50	38.40	59.00	2250	F	SCD 35
500	H1EM500BK00	NJ3	51.50	43.40	66.00	3000	F	SCD 35
750	H1EM750BK00	NJ3	51.50	43.40	66.00	4200	F	SCD 35

*WALL MOUNTING KIT AND/OR DRIP PLATE KIT REQUIRED.
REFER TO PAGES 271 TO 273 FOR DETAILS.

480 Delta Primary Volts

208Y/120 Secondary Volts

60 Hz

kVA	Catalog Number	Case Style (Pages 260 - 267)	Approx. Dimensions (Inches)			Approx. Weight (Lbs.)	Mtg Type W - Wall F - Floor	Wiring Diagram (Pages 276 - 288)
			Width	Depth	Height			
15	H1EM015KB00	NH5	19.40	20.20	21.50	240	F or W *	SCD 35
30	H1EM030KB00	NH6	23.90	25.00	28.75	360	F or W *	SCD 35
45	H1EM045KB00	NH6	23.90	25.00	28.75	465	F or W *	SCD 35
75	H1EM075KB00	NH3	26.00	25.00	38.00	740	F or W *	SCD 35
112.5	H1EM112KB00	NH4	32.00	29.50	41.00	1100	F	SCD 35
150	H1EM150KB00	NH4	32.00	29.50	41.00	1350	F	SCD 35
225	H1EM225KB00	NJ1	39.50	34.00	51.50	1800	F	SCD 35
300	H1EM300KB00	NJ2	48.50	38.40	59.00	2250	F	SCD 35
500	H1EM500KB00	NJ3	51.50	43.40	66.00	3000	F	SCD 35
750	H1EM750KB00	NJ3	51.50	43.40	66.00	4200	F	SCD 35

*WALL MOUNTING KIT AND/OR DRIP PLATE KIT REQUIRED.
REFER TO PAGES 271 TO 273 FOR DETAILS.



FOR TERMINATION DETAILS SEE PAGE 275.

FOR ACCESSORIES SEE PAGES 271 TO 274.





COPPER WOUND, THREE PHASE, SHIELDED 0° PHASE SHIFT

480 Delta Primary Volts

480Y/277 Secondary Volts

60 Hz

kVA	Catalog Number	Case Style (Pages 260 - 267)	Approx. Dimensions (Inches)			Approx. Weight (Lbs.)	Mtg Type W - Wall F - Floor	Wiring Diagram (Pages 276 - 288)
			Width	Depth	Height			
15	H1EM015KK00	NH5	19.40	20.20	21.50	240	F or W *	SCD 35
30	H1EM030KK00	NH6	23.90	25.00	28.75	360	F or W *	SCD 35
45	H1EM045KK00	NH6	23.90	25.00	28.75	465	F or W *	SCD 35
75	H1EM075KK00	NH3	26.00	25.00	38.00	740	F or W *	SCD 35
112.5	H1EM112KK00	NH4	32.00	29.50	41.00	1100	F	SCD 35
150	H1EM150KK00	NH4	32.00	29.50	41.00	1350	F	SCD 35
225	H1EM225KK00	NJ1	39.50	34.00	51.50	1800	F	SCD 35
300	H1EM300KK00	NJ2	48.50	38.40	59.00	2250	F	SCD 35
500	H1EM500KK00	NJ3	51.50	43.40	66.00	3000	F	SCD 35
750	H1EM750KK00	NJ3	51.50	43.40	66.00	4200	F	SCD 35

*WALL MOUNTING KIT AND/OR DRIP PLATE KIT REQUIRED.
REFER TO PAGES 271 TO 273 FOR DETAILS.

600 Delta Primary Volts

208Y/120 Secondary Volts

60 Hz

kVA	Catalog Number	Case Style (Pages 260 - 267)	Approx. Dimensions (Inches)			Approx. Weight (Lbs.)	Mtg Type W - Wall F - Floor	Wiring Diagram (Pages 276 - 288)
			Width	Depth	Height			
15	H1EM015PB00	NH5	19.40	20.20	21.50	240	F or W *	SCD 35
30	H1EM030PB00	NH6	23.90	25.00	28.75	360	F or W *	SCD 35
45	H1EM045PB00	NH6	23.90	25.00	28.75	465	F or W *	SCD 35
75	H1EM075PB00	NH3	26.00	25.00	38.00	740	F or W *	SCD 35
112.5	H1EM112PB00	NH4	32.00	29.50	41.00	1100	F	SCD 35
150	H1EM150PB00	NH4	32.00	29.50	41.00	1350	F	SCD 35
225	H1EM225PB00	NJ1	39.50	34.00	51.50	1800	F	SCD 35
300	H1EM300PB00	NJ2	48.50	38.40	59.00	2250	F	SCD 35
500	H1EM500PB00	NJ3	51.50	43.40	66.00	3000	F	SCD 35
750	H1EM750PB00	NJ3	51.50	43.40	66.00	4200	F	SCD 35

*WALL MOUNTING KIT AND/OR DRIP PLATE KIT REQUIRED.
REFER TO PAGES 271 TO 273 FOR DETAILS.

600 Delta Primary Volts

480Y/277 Secondary Volts

60 Hz

kVA	Catalog Number	Case Style (Pages 260 - 267)	Approx. Dimensions (Inches)			Approx. Weight (Lbs.)	Mtg Type W - Wall F - Floor	Wiring Diagram (Pages 276 - 288)
			Width	Depth	Height			
15	H1EM015PK00	NH5	19.40	20.20	21.50	240	F or W *	SCD 35
30	H1EM030PK00	NH6	23.90	25.00	28.75	360	F or W *	SCD 35
45	H1EM045PK00	NH6	23.90	25.00	28.75	465	F or W *	SCD 35
75	H1EM075PK00	NH3	26.00	25.00	38.00	740	F or W *	SCD 35
112.5	H1EM112PK00	NH4	32.00	29.50	41.00	1100	F	SCD 35
150	H1EM150PK00	NH4	32.00	29.50	41.00	1350	F	SCD 35
225	H1EM225PK00	NJ1	39.50	34.00	51.50	1800	F	SCD 35
300	H1EM300PK00	NJ2	48.50	38.40	59.00	2250	F	SCD 35
500	H1EM500PK00	NJ3	51.50	43.40	66.00	3000	F	SCD 35
750	H1EM750PK00	NJ3	51.50	43.40	66.00	4200	F	SCD 35

*WALL MOUNTING KIT AND/OR DRIP PLATE KIT REQUIRED.
REFER TO PAGES 271 TO 273 FOR DETAILS.



SECTION 7



COPPER WOUND, THREE PHASE, SHIELDED -30° PHASE SHIFT

208 Wye Primary Volts

208Y/120 Secondary Volts

60 Hz

kVA	Catalog Number	Case Style (Pages 260 - 267)	Approx. Dimensions (Inches)			Approx. Weight (Lbs.)	Mtg Type W - Wall F - Floor	Wiring Diagram (Pages 276 - 288)
			Width	Depth	Height			
15	H1EM015BB30	NH5	19.40	20.20	21.50	240	F or W *	SCD 35
30	H1EM030BB30	NH6	23.90	25.00	28.75	360	F or W *	SCD 35
45	H1EM045BB30	NH6	23.90	25.00	28.75	465	F or W *	SCD 35
75	H1EM075BB30	NH3	26.00	25.00	38.00	740	F or W *	SCD 35
112.5	H1EM112BB30	NH4	32.00	29.50	41.00	1100	F	SCD 35
150	H1EM150BB30	NH4	32.00	29.50	41.00	1350	F	SCD 35
225	H1EM225BB30	NJ1	39.50	34.00	51.50	1800	F	SCD 35
300	H1EM300BB30	NJ2	48.50	38.40	59.00	2250	F	SCD 35
500	H1EM500BB30	NJ3	51.50	43.40	66.00	3000	F	SCD 35
750	H1EM750BB30	NJ3	51.50	43.40	66.00	4200	F	SCD 35

*WALL MOUNTING KIT AND/OR DRIP PLATE KIT REQUIRED.
REFER TO PAGES 271 TO 273 FOR DETAILS.

208 Wye Primary Volts

480Y/277 Secondary Volts

60 Hz

kVA	Catalog Number	Case Style (Pages 260 - 267)	Approx. Dimensions (Inches)			Approx. Weight (Lbs.)	Mtg Type W - Wall F - Floor	Wiring Diagram (Pages 276 - 288)
			Width	Depth	Height			
15	H1EM015BK30	NH5	19.40	20.20	21.50	240	F or W *	SCD 35
30	H1EM030BK30	NH6	23.90	25.00	28.75	360	F or W *	SCD 35
45	H1EM045BK30	NH6	23.90	25.00	28.75	465	F or W *	SCD 35
75	H1EM075BK30	NH3	26.00	25.00	38.00	740	F or W *	SCD 35
112.5	H1EM112BK30	NH4	32.00	29.50	41.00	1100	F	SCD 35
150	H1EM150BK30	NH4	32.00	29.50	41.00	1350	F	SCD 35
225	H1EM225BK30	NJ1	39.50	34.00	51.50	1800	F	SCD 35
300	H1EM300BK30	NJ2	48.50	38.40	59.00	2250	F	SCD 35
500	H1EM500BK30	NJ3	51.50	43.40	66.00	3000	F	SCD 35
750	H1EM750BK30	NJ3	51.50	43.40	66.00	4200	F	SCD 35

*WALL MOUNTING KIT AND/OR DRIP PLATE KIT REQUIRED.
REFER TO PAGES 271 TO 273 FOR DETAILS.

480 Wye Primary Volts

208Y/120 Secondary Volts

60 Hz

kVA	Catalog Number	Case Style (Pages 260 - 267)	Approx. Dimensions (Inches)			Approx. Weight (Lbs.)	Mtg Type W - Wall F - Floor	Wiring Diagram (Pages 276 - 288)
			Width	Depth	Height			
15	H1EM015KB30	NH5	19.40	20.20	21.50	240	F or W *	SCD 35
30	H1EM030KB30	NH6	23.90	25.00	28.75	360	F or W *	SCD 35
45	H1EM045KB30	NH6	23.90	25.00	28.75	465	F or W *	SCD 35
75	H1EM075KB30	NH3	26.00	25.00	38.00	740	F or W *	SCD 35
112.5	H1EM112KB30	NH4	32.00	29.50	41.00	1100	F	SCD 35
150	H1EM150KB30	NH4	32.00	29.50	41.00	1350	F	SCD 35
225	H1EM225KB30	NJ1	39.50	34.00	51.50	1800	F	SCD 35
300	H1EM300KB30	NJ2	48.50	38.40	59.00	2250	F	SCD 35
500	H1EM500KB30	NJ3	51.50	43.40	66.00	3000	F	SCD 35
750	H1EM750KB30	NJ3	51.50	43.40	66.00	4200	F	SCD 35

*WALL MOUNTING KIT AND/OR DRIP PLATE KIT REQUIRED.
REFER TO PAGES 271 TO 273 FOR DETAILS.



FOR TERMINATION DETAILS SEE PAGE 275.

FOR ACCESSORIES SEE PAGES 271 TO 274.

Data subject to change without notice.





COPPER WOUND, THREE PHASE, SHIELDED -30° PHASE SHIFT

480 Wye Primary Volts

480Y/277 Secondary Volts

60 Hz

kVA	Catalog Number	Case Style (Pages 260 - 267)	Approx. Dimensions (Inches)			Approx. Weight (Lbs.)	Mtg Type W - Wall F - Floor	Wiring Diagram (Pages 276 - 288)
			Width	Depth	Height			
15	H1EM015KK30	NH5	19.40	20.20	21.50	240	F or W *	SCD 35
30	H1EM030KK30	NH6	23.90	25.00	28.75	360	F or W *	SCD 35
45	H1EM045KK30	NH6	23.90	25.00	28.75	465	F or W *	SCD 35
75	H1EM075KK30	NH3	26.00	25.00	38.00	740	F or W *	SCD 35
112.5	H1EM112KK30	NH4	32.00	29.50	41.00	1100	F	SCD 35
150	H1EM150KK30	NH4	32.00	29.50	41.00	1350	F	SCD 35
225	H1EM225KK30	NJ1	39.50	34.00	51.50	1800	F	SCD 35
300	H1EM300KK30	NJ2	48.50	38.40	59.00	2250	F	SCD 35
500	H1EM500KK30	NJ3	51.50	43.40	66.00	3000	F	SCD 35
750	H1EM750KK30	NJ3	51.50	43.40	66.00	4200	F	SCD 35

*WALL MOUNTING KIT AND/OR DRIP PLATE KIT REQUIRED.
REFER TO PAGES 271 TO 273 FOR DETAILS.

600 Wye Primary Volts

208Y/120 Secondary Volts

60 Hz

kVA	Catalog Number	Case Style (Pages 260 - 267)	Approx. Dimensions (Inches)			Approx. Weight (Lbs.)	Mtg Type W - Wall F - Floor	Wiring Diagram (Pages 276 - 288)
			Width	Depth	Height			
15	H1EM015PB30	NH5	19.40	20.20	21.50	240	F or W *	SCD 35
30	H1EM030PB30	NH6	23.90	25.00	28.75	360	F or W *	SCD 35
45	H1EM045PB30	NH6	23.90	25.00	28.75	465	F or W *	SCD 35
75	H1EM075PB30	NH3	26.00	25.00	38.00	740	F or W *	SCD 35
112.5	H1EM112PB30	NH4	32.00	29.50	41.00	1100	F	SCD 35
150	H1EM150PB30	NH4	32.00	29.50	41.00	1350	F	SCD 35
225	H1EM225PB30	NJ1	39.50	34.00	51.50	1800	F	SCD 35
300	H1EM300PB30	NJ2	48.50	38.40	59.00	2250	F	SCD 35
500	H1EM500PB30	NJ3	51.50	43.40	66.00	3000	F	SCD 35
750	H1EM750PB30	NJ3	51.50	43.40	66.00	4200	F	SCD 35

*WALL MOUNTING KIT AND/OR DRIP PLATE KIT REQUIRED.
REFER TO PAGES 271 TO 273 FOR DETAILS.

600 Wye Primary Volts

480Y/277 Secondary Volts

60 Hz

kVA	Catalog Number	Case Style (Pages 260 - 267)	Approx. Dimensions (Inches)			Approx. Weight (Lbs.)	Mtg Type W - Wall F - Floor	Wiring Diagram (Pages 276 - 288)
			Width	Depth	Height			
15	H1EM015PK30	NH5	19.40	20.20	21.50	240	F or W *	SCD 35
30	H1EM030PK30	NH6	23.90	25.00	28.75	360	F or W *	SCD 35
45	H1EM045PK30	NH6	23.90	25.00	28.75	465	F or W *	SCD 35
75	H1EM075PK30	NH3	26.00	25.00	38.00	740	F or W *	SCD 35
112.5	H1EM112PK30	NH4	32.00	29.50	41.00	1100	F	SCD 35
150	H1EM150PK30	NH4	32.00	29.50	41.00	1350	F	SCD 35
225	H1EM225PK30	NJ1	39.50	34.00	51.50	1800	F	SCD 35
300	H1EM300PK30	NJ2	48.50	38.40	59.00	2250	F	SCD 35
500	H1EM500PK30	NJ3	51.50	43.40	66.00	3000	F	SCD 35
750	H1EM750PK30	NJ3	51.50	43.40	66.00	4200	F	SCD 35

*WALL MOUNTING KIT AND/OR DRIP PLATE KIT REQUIRED.
REFER TO PAGES 271 TO 273 FOR DETAILS.





HPS SUPERCENTURION®

600 VOLT CLASS ENERGY EFFICIENT HARMONIC MITIGATING TRANSFORMERS

Harmonic Mitigating Transformer Efficiencies:

The HPS Centurion energy efficient, harmonic mitigating transformer with zero sequence flux cancellation technology is specifically designed to treat the harmonics generated by computer equipment and other non-linear, power electronic loads. Combining zero sequence flux cancellation with phase shifting treats 3rd, 5th, 7th, 9th, 15th, 17th and 19th, harmonics within its secondary windings. Typical applications of severe non-linear loading conditions include data centers, internet-service providers, telecom sites, call centers, broadcast centers, etc.

HPS SuperCENTURION (PART NUMBER PREFIX S1EM OR S2EM)

- Exceeds DOE 10 CFR Part 431 and C802.2 efficiencies at 35% of rated load.
- Efficiency performance will meet the NEMA Premium® guidelines; 30% lower losses than DOE 10 CFR Part 431 and (if applicable) C802.2 efficiency standards; when measured under a linear load profile.
- Efficiencies will exceed DOE 10 CFR Part 431 and (if applicable) C802.2 efficiency standards; at an operating range from 35% to 65% of rated load when measured under a non-linear load profile up to K20.
- Copper & Aluminum Available.





HPS SUPERCENTURION®
600 VOLT CLASS ENERGY EFFICIENT
HARMONIC MITIGATING TRANSFORMERS

THREE PHASE STANDARD SPECIFICATIONS

15 to 45 kVA

75 TO 750 KVA



THREE PHASE SPECIFICATIONS

NEMA 3R

	15 to 45 kVA	75 to 750 kVA
Efficiency	Efficiency performance will meet the NEMA Premium® guidelines; 30% lower losses than DOE 10 CFR Part 431 and (if applicable) C802.2 efficiency standards; when measured under a linear load profile. Efficiencies will exceed DOE 10 CFR Part 431 and (if applicable) C802.2 efficiency standards; at an operating range from 35% to 65% of rated load when measured under a non-linear load profile up to K20 .	
UL Listed	File: E112313	File: E112313
CSA Certified	File: LR3902	File: LR3902
Frequency	60 Hz	60 Hz
Insulation System	220°C (150°C rise) 200°C (130°C rise) on 15 & 30kVA copper (optional 115°C and 80°C rise available)	220°C (150°C rise) (optional 115°C and 80°C rise available)
Electrostatic Shield	60dB Common Mode - typical	60dB Common Mode - typical
Enclosure Type	Heavy Duty Ventilated Type 3R Optional Type 4, 4X (stainless steel) and 12.	Heavy Duty Ventilated Type 3R Optional Type 4, 4X (stainless steel) and 12.
Enclosure Finish	ANSI 61 Grey, UL50	ANSI 61 Grey, UL50
Neutral	Neutral terminal for field connection (on applicable units).	Neutral terminal for field connection (on applicable units).
Standard Primary Taps	Refer to wiring diagrams for details.	Refer to wiring diagrams for details.
Termination	Front accessible separate high and low voltage terminals; connectors suitable for aluminum and copper are provided for easy cable installation.	Front accessible separate high and low voltage terminals; connectors suitable for aluminum and copper are provided for easy cable installation.
Conduit Knock-Outs	Standard on all units.	Standard on 75 kVA & 150 kVA units.
Impedance	Typically 2.5% to 6.5%	Typically 2.5% to 6.5%
Mounting	Floor or wall/ceiling mounting available. Refer to selection tables for details.	Floor or wall/ceiling mounting available. Refer to selection tables for details.
Seismic	Meets Occupancy Category III Ip=1.25 for Ss=1.0g per IBC 2006; section 1613, earthquake loads and NBCC 2005 for ground level installations only for all locations in North America.	Meets Occupancy Category III Ip=1.25 for Ss=1.0g per IBC 2006; section 1613, earthquake loads and NBCC 2005 for ground level installations only for all locations in North America.
Sound level	Meets NEMA ST-20 standards. (Optional low noise units available)	Meets NEMA ST-20 standards. (Optional low noise units available)

* Optional TVSS available. Dual Output option also available. Features as listed above may differ. Contact sales for more details.

FOR TERMINATION DETAILS SEE PAGE 275.

FOR ACCESSORIES SEE PAGES 271 TO 274.

SECTION 7



SECTION 7

ENERGY EFFICIENT HARMONIC MITIGATING

ALUMINUM WOUND, THREE PHASE, SHIELDED, 0° PHASE SHIFT



208 Delta Primary Volts

208Y/120 Secondary Volts

60 Hz

kVA	Catalog Number	Case Style (Pages 260 - 267)	Approx. Dimensions (Inches)			Approx. Weight (Lbs.)	Mtg Type W - Wall F - Floor	Wiring Diagram (Pages 276 - 288)
			Width	Depth	Height			
15	S1EM015BB00S	NH5	19.40	20.20	21.50	250	F or W *	SCD 35
30	S1EM030BB00S	NH6	23.90	25.00	28.75	350	F or W *	SCD 35
45	S1EM045BB00S	NH3	26.00	25.00	38.00	460	F or W *	SCD 35
75	S1EM075BB00S	NH4	32.00	29.50	41.00	650	F	SCD 35
112.5	S1EM112BB00S	NH4	32.00	29.50	41.00	960	F	SCD 35
150	S1EM150BB00S	NH4	32.00	29.50	41.00	1210	F	SCD 35
225	S1EM225BB00S	NJ2	48.50	38.40	59.00	1970	F	SCD 35
300	S1EM300BB00S	NJ2	48.50	38.40	59.00	2590	F	SCD 35
500	S1EM500BB00S	NJ3	51.50	43.40	66.00	4460	F	SCD 35
750	S1EM750BB00S	NJ6	64.00	57.40	71.00	6260	F	SCD 35

*WALL MOUNTING KIT AND/OR DRIP PLATE KIT REQUIRED.
REFER TO PAGES 271 TO 273 FOR DETAILS.

208 Delta Primary Volts

480Y/277 Secondary Volts

60 Hz

kVA	Catalog Number	Case Style (Pages 260 - 267)	Approx. Dimensions (Inches)			Approx. Weight (Lbs.)	Mtg Type W - Wall F - Floor	Wiring Diagram (Pages 276 - 288)
			Width	Depth	Height			
15	S1EM015BK00S	NH5	19.40	20.20	21.50	250	F or W *	SCD 35
30	S1EM030BK00S	NH6	23.90	25.00	28.75	350	F or W *	SCD 35
45	S1EM045BK00S	NH3	26.00	25.00	38.00	460	F or W *	SCD 35
75	S1EM075BK00S	NH4	32.00	29.50	41.00	650	F	SCD 35
112.5	S1EM112BK00S	NH4	32.00	29.50	41.00	960	F	SCD 35
150	S1EM150BK00S	NH4	32.00	29.50	41.00	1210	F	SCD 35
225	S1EM225BK00S	NJ2	48.50	38.40	59.00	1970	F	SCD 35
300	S1EM300BK00S	NJ2	48.50	38.40	59.00	2590	F	SCD 35
500	S1EM500BK00S	NJ3	51.50	43.40	66.00	4460	F	SCD 35
750	S1EM750BK00S	NJ6	64.00	57.40	71.00	6260	F	SCD 35

*WALL MOUNTING KIT AND/OR DRIP PLATE KIT REQUIRED.
REFER TO PAGES 271 TO 273 FOR DETAILS.

480 Delta Primary Volts

208Y/120 Secondary Volts

60 Hz

kVA	Catalog Number	Case Style (Pages 260 - 267)	Approx. Dimensions (Inches)			Approx. Weight (Lbs.)	Mtg Type W - Wall F - Floor	Wiring Diagram (Pages 276 - 288)
			Width	Depth	Height			
15	S1EM015KB00S	NH5	19.40	20.20	21.50	250	F or W *	SCD 35
30	S1EM030KB00S	NH6	23.90	25.00	28.75	350	F or W *	SCD 35
45	S1EM045KB00S	NH3	26.00	25.00	38.00	460	F or W *	SCD 35
75	S1EM075KB00S	NH4	32.00	29.50	41.00	650	F	SCD 35
112.5	S1EM112KB00S	NH4	32.00	29.50	41.00	960	F	SCD 35
150	S1EM150KB00S	NH4	32.00	29.50	41.00	1210	F	SCD 35
225	S1EM225KB00S	NJ2	48.50	38.40	59.00	1970	F	SCD 35
300	S1EM300KB00S	NJ2	48.50	38.40	59.00	2590	F	SCD 35
500	S1EM500KB00S	NJ3	51.50	43.40	66.00	4460	F	SCD 35
750	S1EM750KB00S	NJ6	64.00	57.40	71.00	6260	F	SCD 35

*WALL MOUNTING KIT AND/OR DRIP PLATE KIT REQUIRED.
REFER TO PAGES 271 TO 273 FOR DETAILS.

SECTION 7



FOR TERMINATION DETAILS SEE PAGE 275.

FOR ACCESSORIES SEE PAGES 271 TO 274.



ALUMINUM WOUND, THREE PHASE, SHIELDED, 0° PHASE SHIFT



480 Delta Primary Volts

480Y/277 Secondary Volts

60 Hz

kVA	Catalog Number	Case Style (Pages 260 - 267)	Approx. Dimensions (Inches)			Approx. Weight (Lbs.)	Mtg Type W - Wall F - Floor	Wiring Diagram (Pages 276 - 288)
			Width	Depth	Height			
15	S1EM015KK00S	NH5	19.40	20.20	21.50	250	F or W *	SCD 35
30	S1EM030KK00S	NH6	23.90	25.00	28.75	350	F or W *	SCD 35
45	S1EM045KK00S	NH3	26.00	25.00	38.00	460	F or W *	SCD 35
75	S1EM075KK00S	NH4	32.00	29.50	41.00	650	F	SCD 35
112.5	S1EM112KK00S	NH4	32.00	29.50	41.00	960	F	SCD 35
150	S1EM150KK00S	NH4	32.00	29.50	41.00	1210	F	SCD 35
225	S1EM225KK00S	NJ2	48.50	38.40	59.00	1970	F	SCD 35
300	S1EM300KK00S	NJ2	48.50	38.40	59.00	2590	F	SCD 35
500	S1EM500KK00S	NJ3	51.50	43.40	66.00	4460	F	SCD 35
750	S1EM750KK00S	NJ6	64.00	57.40	71.00	6260	F	SCD 35

*WALL MOUNTING KIT AND/OR DRIP PLATE KIT REQUIRED.
REFER TO PAGES 271 TO 273 FOR DETAILS.

600 Delta Primary Volts

208Y/120 Secondary Volts

60 Hz

kVA	Catalog Number	Case Style (Pages 260 - 267)	Approx. Dimensions (Inches)			Approx. Weight (Lbs.)	Mtg Type W - Wall F - Floor	Wiring Diagram (Pages 276 - 288)
			Width	Depth	Height			
15	S1EM015PB00S	NH5	19.40	20.20	21.50	250	F or W *	SCD 35
30	S1EM030PB00S	NH6	23.90	25.00	28.75	350	F or W *	SCD 35
45	S1EM045PB00S	NH3	26.00	25.00	38.00	460	F or W *	SCD 35
75	S1EM075PB00S	NH4	32.00	29.50	41.00	650	F	SCD 35
112.5	S1EM112PB00S	NH4	32.00	29.50	41.00	960	F	SCD 35
150	S1EM150PB00S	NH4	32.00	29.50	41.00	1210	F	SCD 35
225	S1EM225PB00S	NJ2	48.50	38.40	59.00	1970	F	SCD 35
300	S1EM300PB00S	NJ2	48.50	38.40	59.00	2590	F	SCD 35
500	S1EM500PB00S	NJ3	51.50	43.40	66.00	4460	F	SCD 35
750	S1EM750PB00S	NJ6	64.00	57.40	71.00	6260	F	SCD 35

*WALL MOUNTING KIT AND/OR DRIP PLATE KIT REQUIRED.
REFER TO PAGES 271 TO 273 FOR DETAILS.

600 Delta Primary Volts

480Y/277 Secondary Volts

60 Hz

kVA	Catalog Number	Case Style (Pages 260 - 267)	Approx. Dimensions (Inches)			Approx. Weight (Lbs.)	Mtg Type W - Wall F - Floor	Wiring Diagram (Pages 276 - 288)
			Width	Depth	Height			
15	S1EM015PK00S	NH5	19.40	20.20	21.50	250	F or W *	SCD 35
30	S1EM030PK00S	NH6	23.90	25.00	28.75	350	F or W *	SCD 35
45	S1EM045PK00S	NH3	26.00	25.00	38.00	460	F or W *	SCD 35
75	S1EM075PK00S	NH4	32.00	29.50	41.00	650	F	SCD 35
112.5	S1EM112PK00S	NH4	32.00	29.50	41.00	960	F	SCD 35
150	S1EM150PK00S	NH4	32.00	29.50	41.00	1210	F	SCD 35
225	S1EM225PK00S	NJ2	48.50	38.40	59.00	1970	F	SCD 35
300	S1EM300PK00S	NJ2	48.50	38.40	59.00	2590	F	SCD 35
500	S1EM500PK00S	NJ3	51.50	43.40	66.00	4460	F	SCD 35
750	S1EM750PK00S	NJ6	64.00	57.40	71.00	6260	F	SCD 35

*WALL MOUNTING KIT AND/OR DRIP PLATE KIT REQUIRED.
REFER TO PAGES 271 TO 273 FOR DETAILS.



SECTION 7

ENERGY EFFICIENT HARMONIC MITIGATING

ALUMINUM WOUND, THREE PHASE, SHIELDED, -30° PHASE SHIFT



208 Wye Primary Volts

208Y/120 Secondary Volts

60 Hz

kVA	Catalog Number	Case Style (Pages 260 - 267)	Approx. Dimensions (Inches)			Approx. Weight (Lbs.)	Mtg Type W - Wall F - Floor	Wiring Diagram (Pages 276 - 288)
			Width	Depth	Height			
15	S1EM015BB30S	NH5	19.40	20.20	21.50	250	F or W *	SCD 35
30	S1EM030BB30S	NH6	23.90	25.00	28.75	350	F or W *	SCD 35
45	S1EM045BB30S	NH3	26.00	25.00	38.00	460	F or W *	SCD 35
75	S1EM075BB30S	NH4	32.00	29.50	41.00	650	F	SCD 35
112.5	S1EM112BB30S	NH4	32.00	29.50	41.00	960	F	SCD 35
150	S1EM150BB30S	NH4	32.00	29.50	41.00	1210	F	SCD 35
225	S1EM225BB30S	NJ2	48.50	38.40	59.00	1970	F	SCD 35
300	S1EM300BB30S	NJ2	48.50	38.40	59.00	2590	F	SCD 35
500	S1EM500BB30S	NJ3	51.50	43.40	66.00	4460	F	SCD 35
750	S1EM750BB30S	NJ6	64.00	57.40	71.00	6260	F	SCD 35

*WALL MOUNTING KIT AND/OR DRIP PLATE KIT REQUIRED.
REFER TO PAGES 271 TO 273 FOR DETAILS.

208 Wye Primary Volts

480Y/277 Secondary Volts

60 Hz

kVA	Catalog Number	Case Style (Pages 260 - 267)	Approx. Dimensions (Inches)			Approx. Weight (Lbs.)	Mtg Type W - Wall F - Floor	Wiring Diagram (Pages 276 - 288)
			Width	Depth	Height			
15	S1EM015BK30S	NH5	19.40	20.20	21.50	250	F or W *	SCD 35
30	S1EM030BK30S	NH6	23.90	25.00	28.75	350	F or W *	SCD 35
45	S1EM045BK30S	NH3	26.00	25.00	38.00	460	F or W *	SCD 35
75	S1EM075BK30S	NH4	32.00	29.50	41.00	650	F	SCD 35
112.5	S1EM112BK30S	NH4	32.00	29.50	41.00	960	F	SCD 35
150	S1EM150BK30S	NH4	32.00	29.50	41.00	1210	F	SCD 35
225	S1EM225BK30S	NJ2	48.50	38.40	59.00	1970	F	SCD 35
300	S1EM300BK30S	NJ2	48.50	38.40	59.00	2590	F	SCD 35
500	S1EM500BK30S	NJ3	51.50	43.40	66.00	4460	F	SCD 35
750	S1EM750BK30S	NJ6	64.00	57.40	71.00	6260	F	SCD 35

*WALL MOUNTING KIT AND/OR DRIP PLATE KIT REQUIRED.
REFER TO PAGES 271 TO 273 FOR DETAILS.

480 Wye Primary Volts

208Y/120 Secondary Volts

60 Hz

kVA	Catalog Number	Case Style (Pages 260 - 267)	Approx. Dimensions (Inches)			Approx. Weight (Lbs.)	Mtg Type W - Wall F - Floor	Wiring Diagram (Pages 276 - 288)
			Width	Depth	Height			
15	S1EM015KB30S	NH5	19.40	20.20	21.50	250	F or W *	SCD 35
30	S1EM030KB30S	NH6	23.90	25.00	28.75	350	F or W *	SCD 35
45	S1EM045KB30S	NH3	26.00	25.00	38.00	460	F or W *	SCD 35
75	S1EM075KB30S	NH4	32.00	29.50	41.00	650	F	SCD 35
112.5	S1EM112KB30S	NH4	32.00	29.50	41.00	960	F	SCD 35
150	S1EM150KB30S	NH4	32.00	29.50	41.00	1210	F	SCD 35
225	S1EM225KB30S	NJ2	48.50	38.40	59.00	1970	F	SCD 35
300	S1EM300KB30S	NJ2	48.50	38.40	59.00	2590	F	SCD 35
500	S1EM500KB30S	NJ3	51.50	43.40	66.00	4460	F	SCD 35
750	S1EM750KB30S	NJ6	64.00	57.40	71.00	6260	F	SCD 35

*WALL MOUNTING KIT AND/OR DRIP PLATE KIT REQUIRED.
REFER TO PAGES 271 TO 273 FOR DETAILS.

SECTION 7



FOR TERMINATION DETAILS SEE PAGE 275.

FOR ACCESSORIES SEE PAGES 271 TO 274.



ALUMINUM WOUND, THREE PHASE, SHIELDED, -30° PHASE SHIFT



480 Wye Primary Volts

480Y/277 Secondary Volts

60 Hz

kVA	Catalog Number	Case Style (Pages 260 - 267)	Approx. Dimensions (Inches)			Approx. Weight (Lbs.)	Mtg Type W - Wall F - Floor	Wiring Diagram (Pages 276 - 288)
			Width	Depth	Height			
15	S1EM015KK30S	NH5	19.40	20.20	21.50	250	F or W *	SCD 35
30	S1EM030KK30S	NH6	23.90	25.00	28.75	350	F or W *	SCD 35
45	S1EM045KK30S	NH3	26.00	25.00	38.00	460	F or W *	SCD 35
75	S1EM075KK30S	NH4	32.00	29.50	41.00	650	F	SCD 35
112.5	S1EM112KK30S	NH4	32.00	29.50	41.00	960	F	SCD 35
150	S1EM150KK30S	NH4	32.00	29.50	41.00	1210	F	SCD 35
225	S1EM225KK30S	NJ2	48.50	38.40	59.00	1970	F	SCD 35
300	S1EM300KK30S	NJ2	48.50	38.40	59.00	2590	F	SCD 35
500	S1EM500KK30S	NJ3	51.50	43.40	66.00	4460	F	SCD 35
750	S1EM750KK30S	NJ6	64.00	57.40	71.00	6260	F	SCD 35

*WALL MOUNTING KIT AND/OR DRIP PLATE KIT REQUIRED.
REFER TO PAGES 271 TO 273 FOR DETAILS.

600 Wye Primary Volts

208Y/120 Secondary Volts

60 Hz

kVA	Catalog Number	Case Style (Pages 260 - 267)	Approx. Dimensions (Inches)			Approx. Weight (Lbs.)	Mtg Type W - Wall F - Floor	Wiring Diagram (Pages 276 - 288)
			Width	Depth	Height			
15	S1EM015PB30S	NH5	19.40	20.20	21.50	250	F or W *	SCD 35
30	S1EM030PB30S	NH6	23.90	25.00	28.75	350	F or W *	SCD 35
45	S1EM045PB30S	NH3	26.00	25.00	38.00	460	F or W *	SCD 35
75	S1EM075PB30S	NH4	32.00	29.50	41.00	650	F	SCD 35
112.5	S1EM112PB30S	NH4	32.00	29.50	41.00	960	F	SCD 35
150	S1EM150PB30S	NH4	32.00	29.50	41.00	1210	F	SCD 35
225	S1EM225PB30S	NJ2	48.50	38.40	59.00	1970	F	SCD 35
300	S1EM300PB30S	NJ2	48.50	38.40	59.00	2590	F	SCD 35
500	S1EM500PB30S	NJ3	51.50	43.40	66.00	4460	F	SCD 35
750	S1EM750PB30S	NJ6	64.00	57.40	71.00	6260	F	SCD 35

*WALL MOUNTING KIT AND/OR DRIP PLATE KIT REQUIRED.
REFER TO PAGES 271 TO 273 FOR DETAILS.

600 Wye Primary Volts

480Y/277 Secondary Volts

60 Hz

kVA	Catalog Number	Case Style (Pages 260 - 267)	Approx. Dimensions (Inches)			Approx. Weight (Lbs.)	Mtg Type W - Wall F - Floor	Wiring Diagram (Pages 276 - 288)
			Width	Depth	Height			
15	S1EM015PK30S	NH5	19.40	20.20	21.50	250	F or W *	SCD 35
30	S1EM030PK30S	NH6	23.90	25.00	28.75	350	F or W *	SCD 35
45	S1EM045PK30S	NH3	26.00	25.00	38.00	460	F or W *	SCD 35
75	S1EM075PK30S	NH4	32.00	29.50	41.00	650	F	SCD 35
112.5	S1EM112PK30S	NH4	32.00	29.50	41.00	960	F	SCD 35
150	S1EM150PK30S	NH4	32.00	29.50	41.00	1210	F	SCD 35
225	S1EM225PK30S	NJ2	48.50	38.40	59.00	1970	F	SCD 35
300	S1EM300PK30S	NJ2	48.50	38.40	59.00	2590	F	SCD 35
500	S1EM500PK30S	NJ3	51.50	43.40	66.00	4460	F	SCD 35
750	S1EM750PK30S	NJ6	64.00	57.40	71.00	6260	F	SCD 35

*WALL MOUNTING KIT AND/OR DRIP PLATE KIT REQUIRED.
REFER TO PAGES 271 TO 273 FOR DETAILS.



SECTION 7

ENERGY EFFICIENT HARMONIC MITIGATING

COPPER WOUND, THREE PHASE, SHIELDED, 0° PHASE SHIFT



208 Delta Primary Volts

208Y/120 Secondary Volts

60 Hz

kVA	Catalog Number	Case Style (Pages 260 - 267)	Approx. Dimensions (Inches)			Approx. Weight (Lbs.)	Mtg Type W - Wall F - Floor	Wiring Diagram (Pages 276 - 288)
			Width	Depth	Height			
15	S1EM015BB00	NH5	19.40	20.20	21.50	250	F or W *	SCD 35
30	S1EM030BB00	NH6	23.90	25.00	28.75	390	F or W *	SCD 35
45	S1EM045BB00	NH6	23.90	25.00	28.75	460	F or W *	SCD 35
75	S1EM075BB00	NH3	26.00	25.00	38.00	660	F or W *	SCD 35
112.5	S1EM112BB00	NH4	32.00	29.50	41.00	1000	F	SCD 35
150	S1EM150BB00	NH4	32.00	29.50	41.00	1250	F	SCD 35
225	S1EM225BB00	NJ1	39.50	34.00	51.50	1960	F	SCD 35
300	S1EM300BB00	NJ2	48.50	38.40	59.00	2470	F	SCD 35
500	S1EM500BB00	NJ3	51.50	43.40	66.00	3930	F	SCD 35
750	S1EM750BB00	NJ6	64.00	57.40	71.00	5760	F	SCD 35

*WALL MOUNTING KIT AND/OR DRIP PLATE KIT REQUIRED.
REFER TO PAGES 271 TO 273 FOR DETAILS.

208 Delta Primary Volts

480Y/277 Secondary Volts

60 Hz

kVA	Catalog Number	Case Style (Pages 260 - 267)	Approx. Dimensions (Inches)			Approx. Weight (Lbs.)	Mtg Type W - Wall F - Floor	Wiring Diagram (Pages 276 - 288)
			Width	Depth	Height			
15	S1EM015BK00	NH5	19.40	20.20	21.50	250	F or W *	SCD 35
30	S1EM030BK00	NH6	23.90	25.00	28.75	390	F or W *	SCD 35
45	S1EM045BK00	NH6	23.90	25.00	28.75	460	F or W *	SCD 35
75	S1EM075BK00	NH3	26.00	25.00	38.00	660	F or W *	SCD 35
112.5	S1EM112BK00	NH4	32.00	29.50	41.00	1000	F	SCD 35
150	S1EM150BK00	NH4	32.00	29.50	41.00	1250	F	SCD 35
225	S1EM225BK00	NJ1	39.50	34.00	51.50	1960	F	SCD 35
300	S1EM300BK00	NJ2	48.50	38.40	59.00	2470	F	SCD 35
500	S1EM500BK00	NJ3	51.50	43.40	66.00	3930	F	SCD 35
750	S1EM750BK00	NJ6	64.00	57.40	71.00	5760	F	SCD 35

*WALL MOUNTING KIT AND/OR DRIP PLATE KIT REQUIRED.
REFER TO PAGES 271 TO 273 FOR DETAILS.

480 Delta Primary Volts

208Y/120 Secondary Volts

60 Hz

kVA	Catalog Number	Case Style (Pages 260 - 267)	Approx. Dimensions (Inches)			Approx. Weight (Lbs.)	Mtg Type W - Wall F - Floor	Wiring Diagram (Pages 276 - 288)
			Width	Depth	Height			
15	S1EM015KB00	NH5	19.40	20.20	21.50	250	F or W *	SCD 35
30	S1EM030KB00	NH6	23.90	25.00	28.75	390	F or W *	SCD 35
45	S1EM045KB00	NH6	23.90	25.00	28.75	460	F or W *	SCD 35
75	S1EM075KB00	NH3	26.00	25.00	38.00	660	F or W *	SCD 35
112.5	S1EM112KB00	NH4	32.00	29.50	41.00	1000	F	SCD 35
150	S1EM150KB00	NH4	32.00	29.50	41.00	1250	F	SCD 35
225	S1EM225KB00	NJ1	39.50	34.00	51.50	1960	F	SCD 35
300	S1EM300KB00	NJ2	48.50	38.40	59.00	2470	F	SCD 35
500	S1EM500KB00	NJ3	51.50	43.40	66.00	3930	F	SCD 35
750	S1EM750KB00	NJ6	64.00	57.40	71.00	5760	F	SCD 35

*WALL MOUNTING KIT AND/OR DRIP PLATE KIT REQUIRED.
REFER TO PAGES 271 TO 273 FOR DETAILS.

SECTION 7



FOR TERMINATION DETAILS SEE PAGE 275.

FOR ACCESSORIES SEE PAGES 271 TO 274.



COPPER WOUND, THREE PHASE, SHIELDED, 0° PHASE SHIFT



480 Delta Primary Volts

480Y/277 Secondary Volts

60 Hz

kVA	Catalog Number	Case Style (Pages 260 - 267)	Approx. Dimensions (Inches)			Approx. Weight (Lbs.)	Mtg Type W - Wall F - Floor	Wiring Diagram (Pages 276 - 288)
			Width	Depth	Height			
15	S1EM015KK00	NH5	19.40	20.20	21.50	250	F or W *	SCD 35
30	S1EM030KK00	NH6	23.90	25.00	28.75	390	F or W *	SCD 35
45	S1EM045KK00	NH6	23.90	25.00	28.75	460	F or W *	SCD 35
75	S1EM075KK00	NH3	26.00	25.00	38.00	660	F or W *	SCD 35
112.5	S1EM112KK00	NH4	32.00	29.50	41.00	1000	F	SCD 35
150	S1EM150KK00	NH4	32.00	29.50	41.00	1250	F	SCD 35
225	S1EM225KK00	NJ1	39.50	34.00	51.50	1960	F	SCD 35
300	S1EM300KK00	NJ2	48.50	38.40	59.00	2470	F	SCD 35
500	S1EM500KK00	NJ3	51.50	43.40	66.00	3930	F	SCD 35
750	S1EM750KK00	NJ6	64.00	57.40	71.00	5760	F	SCD 35

*WALL MOUNTING KIT AND/OR DRIP PLATE KIT REQUIRED.
REFER TO PAGES 271 TO 273 FOR DETAILS.

600 Delta Primary Volts

208Y/120 Secondary Volts

60 Hz

kVA	Catalog Number	Case Style (Pages 260 - 267)	Approx. Dimensions (Inches)			Approx. Weight (Lbs.)	Mtg Type W - Wall F - Floor	Wiring Diagram (Pages 276 - 288)
			Width	Depth	Height			
15	S1EM015PB00	NH5	19.40	20.20	21.50	250	F or W *	SCD 35
30	S1EM030PB00	NH6	23.90	25.00	28.75	390	F or W *	SCD 35
45	S1EM045PB00	NH6	23.90	25.00	28.75	460	F or W *	SCD 35
75	S1EM075PB00	NH3	26.00	25.00	38.00	660	F or W *	SCD 35
112.5	S1EM112PB00	NH4	32.00	29.50	41.00	1000	F	SCD 35
150	S1EM150PB00	NH4	32.00	29.50	41.00	1250	F	SCD 35
225	S1EM225PB00	NJ1	39.50	34.00	51.50	1960	F	SCD 35
300	S1EM300PB00	NJ2	48.50	38.40	59.00	2470	F	SCD 35
500	S1EM500PB00	NJ3	51.50	43.40	66.00	3930	F	SCD 35
750	S1EM750PB00	NJ6	64.00	57.40	71.00	5760	F	SCD 35

*WALL MOUNTING KIT AND/OR DRIP PLATE KIT REQUIRED.
REFER TO PAGES 271 TO 273 FOR DETAILS.

600 Delta Primary Volts

480Y/277 Secondary Volts

60 Hz

kVA	Catalog Number	Case Style (Pages 260 - 267)	Approx. Dimensions (Inches)			Approx. Weight (Lbs.)	Mtg Type W - Wall F - Floor	Wiring Diagram (Pages 276 - 288)
			Width	Depth	Height			
15	S1EM015PK00	NH5	19.40	20.20	21.50	250	F or W *	SCD 35
30	S1EM030PK00	NH6	23.90	25.00	28.75	390	F or W *	SCD 35
45	S1EM045PK00	NH6	23.90	25.00	28.75	460	F or W *	SCD 35
75	S1EM075PK00	NH3	26.00	25.00	38.00	660	F or W *	SCD 35
112.5	S1EM112PK00	NH4	32.00	29.50	41.00	1000	F	SCD 35
150	S1EM150PK00	NH4	32.00	29.50	41.00	1250	F	SCD 35
225	S1EM225PK00	NJ1	39.50	34.00	51.50	1960	F	SCD 35
300	S1EM300PK00	NJ2	48.50	38.40	59.00	2470	F	SCD 35
500	S1EM500PK00	NJ3	51.50	43.40	66.00	3930	F	SCD 35
750	S1EM750PK00	NJ6	64.00	57.40	71.00	5760	F	SCD 35

*WALL MOUNTING KIT AND/OR DRIP PLATE KIT REQUIRED.
REFER TO PAGES 271 TO 273 FOR DETAILS.

SECTION 7



SECTION 7

ENERGY EFFICIENT HARMONIC MITIGATING

COPPER WOUND, THREE PHASE, SHIELDED, -30° PHASE SHIFT



208 Wye Primary Volts

208Y/120 Secondary Volts

60 Hz

kVA	Catalog Number	Case Style (Pages 260 - 267)	Approx. Dimensions (Inches)			Approx. Weight (Lbs.)	Mtg Type W - Wall F - Floor	Wiring Diagram (Pages 276 - 288)
			Width	Depth	Height			
15	S1EM015BB30	NH5	19.40	20.20	21.50	250	F or W *	SCD 35
30	S1EM030BB30	NH6	23.90	25.00	28.75	390	F or W *	SCD 35
45	S1EM045BB30	NH6	23.90	25.00	28.75	460	F or W *	SCD 35
75	S1EM075BB30	NH3	26.00	25.00	38.00	660	F or W *	SCD 35
112.5	S1EM112BB30	NH4	32.00	29.50	41.00	1000	F	SCD 35
150	S1EM150BB30	NH4	32.00	29.50	41.00	1250	F	SCD 35
225	S1EM225BB30	NJ1	39.50	34.00	51.50	1960	F	SCD 35
300	S1EM300BB30	NJ2	48.50	38.40	59.00	2470	F	SCD 35
500	S1EM500BB30	NJ3	51.50	43.40	66.00	3930	F	SCD 35
750	S1EM750BB30	NJ6	64.00	57.40	71.00	5760	F	SCD 35

*WALL MOUNTING KIT AND/OR DRIP PLATE KIT REQUIRED.
REFER TO PAGES 271 TO 273 FOR DETAILS.

208 Wye Primary Volts

480Y/277 Secondary Volts

60 Hz

kVA	Catalog Number	Case Style (Pages 260 - 267)	Approx. Dimensions (Inches)			Approx. Weight (Lbs.)	Mtg Type W - Wall F - Floor	Wiring Diagram (Pages 276 - 288)
			Width	Depth	Height			
15	S1EM015BK30	NH5	19.40	20.20	21.50	250	F or W *	SCD 35
30	S1EM030BK30	NH6	23.90	25.00	28.75	390	F or W *	SCD 35
45	S1EM045BK30	NH6	23.90	25.00	28.75	460	F or W *	SCD 35
75	S1EM075BK30	NH3	26.00	25.00	38.00	660	F or W *	SCD 35
112.5	S1EM112BK30	NH4	32.00	29.50	41.00	1000	F	SCD 35
150	S1EM150BK30	NH4	32.00	29.50	41.00	1250	F	SCD 35
225	S1EM225BK30	NJ1	39.50	34.00	51.50	1960	F	SCD 35
300	S1EM300BK30	NJ2	48.50	38.40	59.00	2470	F	SCD 35
500	S1EM500BK30	NJ3	51.50	43.40	66.00	3930	F	SCD 35
750	S1EM750BK30	NJ6	64.00	57.40	71.00	5760	F	SCD 35

*WALL MOUNTING KIT AND/OR DRIP PLATE KIT REQUIRED.
REFER TO PAGES 271 TO 273 FOR DETAILS.

480 Wye Primary Volts

208Y/120 Secondary Volts

60 Hz

kVA	Catalog Number	Case Style (Pages 260 - 267)	Approx. Dimensions (Inches)			Approx. Weight (Lbs.)	Mtg Type W - Wall F - Floor	Wiring Diagram (Pages 276 - 288)
			Width	Depth	Height			
15	S1EM015KB30	NH5	19.40	20.20	21.50	250	F or W *	SCD 35
30	S1EM030KB30	NH6	23.90	25.00	28.75	390	F or W *	SCD 35
45	S1EM045KB30	NH6	23.90	25.00	28.75	460	F or W *	SCD 35
75	S1EM075KB30	NH3	26.00	25.00	38.00	660	F or W *	SCD 35
112.5	S1EM112KB30	NH4	32.00	29.50	41.00	1000	F	SCD 35
150	S1EM150KB30	NH4	32.00	29.50	41.00	1250	F	SCD 35
225	S1EM225KB30	NJ1	39.50	34.00	51.50	1960	F	SCD 35
300	S1EM300KB30	NJ2	48.50	38.40	59.00	2470	F	SCD 35
500	S1EM500KB30	NJ3	51.50	43.40	66.00	3930	F	SCD 35
750	S1EM750KB30	NJ6	64.00	57.40	71.00	5760	F	SCD 35

*WALL MOUNTING KIT AND/OR DRIP PLATE KIT REQUIRED.
REFER TO PAGES 271 TO 273 FOR DETAILS.

SECTION 7



FOR TERMINATION DETAILS SEE PAGE 275.

FOR ACCESSORIES SEE PAGES 271 TO 274.



COPPER WOUND, THREE PHASE, SHIELDED, -30° PHASE SHIFT



480 Wye Primary Volts

480Y/277 Secondary Volts

60 Hz

kVA	Catalog Number	Case Style (Pages 260 - 267)	Approx. Dimensions (Inches)			Approx. Weight (Lbs.)	Mtg Type W - Wall F - Floor	Wiring Diagram (Pages 276 - 288)
			Width	Depth	Height			
15	S1EM015KK30	NH5	19.40	20.20	21.50	250	F or W *	SCD 35
30	S1EM030KK30	NH6	23.90	25.00	28.75	390	F or W *	SCD 35
45	S1EM045KK30	NH6	23.90	25.00	28.75	460	F or W *	SCD 35
75	S1EM075KK30	NH3	26.00	25.00	38.00	660	F or W *	SCD 35
112.5	S1EM112KK30	NH4	32.00	29.50	41.00	1000	F	SCD 35
150	S1EM150KK30	NH4	32.00	29.50	41.00	1250	F	SCD 35
225	S1EM225KK30	NJ1	39.50	34.00	51.50	1960	F	SCD 35
300	S1EM300KK30	NJ2	48.50	38.40	59.00	2470	F	SCD 35
500	S1EM500KK30	NJ3	51.50	43.40	66.00	3930	F	SCD 35
750	S1EM750KK30	NJ6	64.00	57.40	71.00	5760	F	SCD 35

*WALL MOUNTING KIT AND/OR DRIP PLATE KIT REQUIRED.
REFER TO PAGES 271 TO 273 FOR DETAILS.

600 Wye Primary Volts

208Y/120 Secondary Volts

60 Hz

kVA	Catalog Number	Case Style (Pages 260 - 267)	Approx. Dimensions (Inches)			Approx. Weight (Lbs.)	Mtg Type W - Wall F - Floor	Wiring Diagram (Pages 276 - 288)
			Width	Depth	Height			
15	S1EM015PB30	NH5	19.40	20.20	21.50	250	F or W *	SCD 35
30	S1EM030PB30	NH6	23.90	25.00	28.75	390	F or W *	SCD 35
45	S1EM045PB30	NH6	23.90	25.00	28.75	460	F or W *	SCD 35
75	S1EM075PB30	NH3	26.00	25.00	38.00	660	F or W *	SCD 35
112.5	S1EM112PB30	NH4	32.00	29.50	41.00	1000	F	SCD 35
150	S1EM150PB30	NH4	32.00	29.50	41.00	1250	F	SCD 35
225	S1EM225PB30	NJ1	39.50	34.00	51.50	1960	F	SCD 35
300	S1EM300PB30	NJ2	48.50	38.40	59.00	2470	F	SCD 35
500	S1EM500PB30	NJ3	51.50	43.40	66.00	3930	F	SCD 35
750	S1EM750PB30	NJ6	64.00	57.40	71.00	5760	F	SCD 35

*WALL MOUNTING KIT AND/OR DRIP PLATE KIT REQUIRED.
REFER TO PAGES 271 TO 273 FOR DETAILS.

600 Wye Primary Volts

480Y/277 Secondary Volts

60 Hz

kVA	Catalog Number	Case Style (Pages 260 - 267)	Approx. Dimensions (Inches)			Approx. Weight (Lbs.)	Mtg Type W - Wall F - Floor	Wiring Diagram (Pages 276 - 288)
			Width	Depth	Height			
15	S1EM015PK30	NH5	19.40	20.20	21.50	250	F or W *	SCD 35
30	S1EM030PK30	NH6	23.90	25.00	28.75	390	F or W *	SCD 35
45	S1EM045PK30	NH6	23.90	25.00	28.75	460	F or W *	SCD 35
75	S1EM075PK30	NH3	26.00	25.00	38.00	660	F or W *	SCD 35
112.5	S1EM112PK30	NH4	32.00	29.50	41.00	1000	F	SCD 35
150	S1EM150PK30	NH4	32.00	29.50	41.00	1250	F	SCD 35
225	S1EM225PK30	NJ1	39.50	34.00	51.50	1960	F	SCD 35
300	S1EM300PK30	NJ2	48.50	38.40	59.00	2470	F	SCD 35
500	S1EM500PK30	NJ3	51.50	43.40	66.00	3930	F	SCD 35
750	S1EM750PK30	NJ6	64.00	57.40	71.00	5760	F	SCD 35

*WALL MOUNTING KIT AND/OR DRIP PLATE KIT REQUIRED.
REFER TO PAGES 271 TO 273 FOR DETAILS.





SECTION 8

ENCAPSULATED DISTRIBUTION TRANSFORMERS

Commercial & Industrial Single Phase and Three Phase

HPS FORTRESS™ Commercial Encapsulated Transformers

Applications & Features	224
Single Phase Standard Specification	226
Single Phase Selection Tables	227
Three Phase Standard Specifications	230
Three Phase Selection Tables	231

HPS TITAN® Industrial Encapsulated Transformers

Applications	233
Features & Benefits	234
Single Phase Standard Specifications	235
Single Phase Selection Tables	236
Three Phase Standard Specifications	238
Three Phase Selection Tables	239

Enclosure Dimensional Drawings	260
Accessories - Enclosure Mounting Kits, Anti-Vibration Pads & Isolators	271
Wiring Schematic Drawings	276

HPS FORTRESS Features

HPS Fortress is an innovative design that provides the ideal solution for commercial applications where **quality, ease of installation, and low cost** are key.

All units are encapsulated with electrical grade silica sand and resin compounds, which completely enclose the core and coil to seal out moisture, airborne contaminants and eliminates corrosion and deterioration.

STANDARD FEATURES

Features	Single Phase	Three Phase
Voltage Groups	9 standard voltage groups	8 standard voltage groups
Ratings	From 50VA to 37.5kVA	From 2kVA to 75kVA
Shield	Standard shield from 750VA and up	Standard shield on all units
Frequency	60 Hz (50Hz standard on four voltage groups)	60Hz standard on all voltage groups
Connection	Standard via copper leads	
Enclosure	NEMA 3R	NEMA 3R (NEMA 4/12 with optional gasket kit installed)
Quality Design	All units are encapsulated with electrical grade silica sand and resin compounds, which completely enclose the core and coil to seal out moisture, airborne contaminants and eliminates corrosion and deterioration.	
Conduit Knockouts	For rear and side entry into an easily accessible and roomy wiring compartment.	
Installation	Wall mounting up to 25kVA, optional wall mounting bracket available on 37.5kVA. Wall mounting template supplied.	Wall mounting up to 9kVA, optional wall mounting bracket available on 15kVA, 30kVA and 45kVA. Wall mounting template supplied.
Warranty	All HPS standard catalog encapsulated transformers come with a 10 year limited* warranty	

*(Please refer to the HPS Warranty on page 28 for full details.)

Inexpensive
& easy



APPLICATIONS

- Shopping Centers
- Schools
- Sports Complexes
- Office Buildings
- Lighting



FOR ACCESSORIES SEE PAGES 271-274.



HPS FORTRESS Features continued

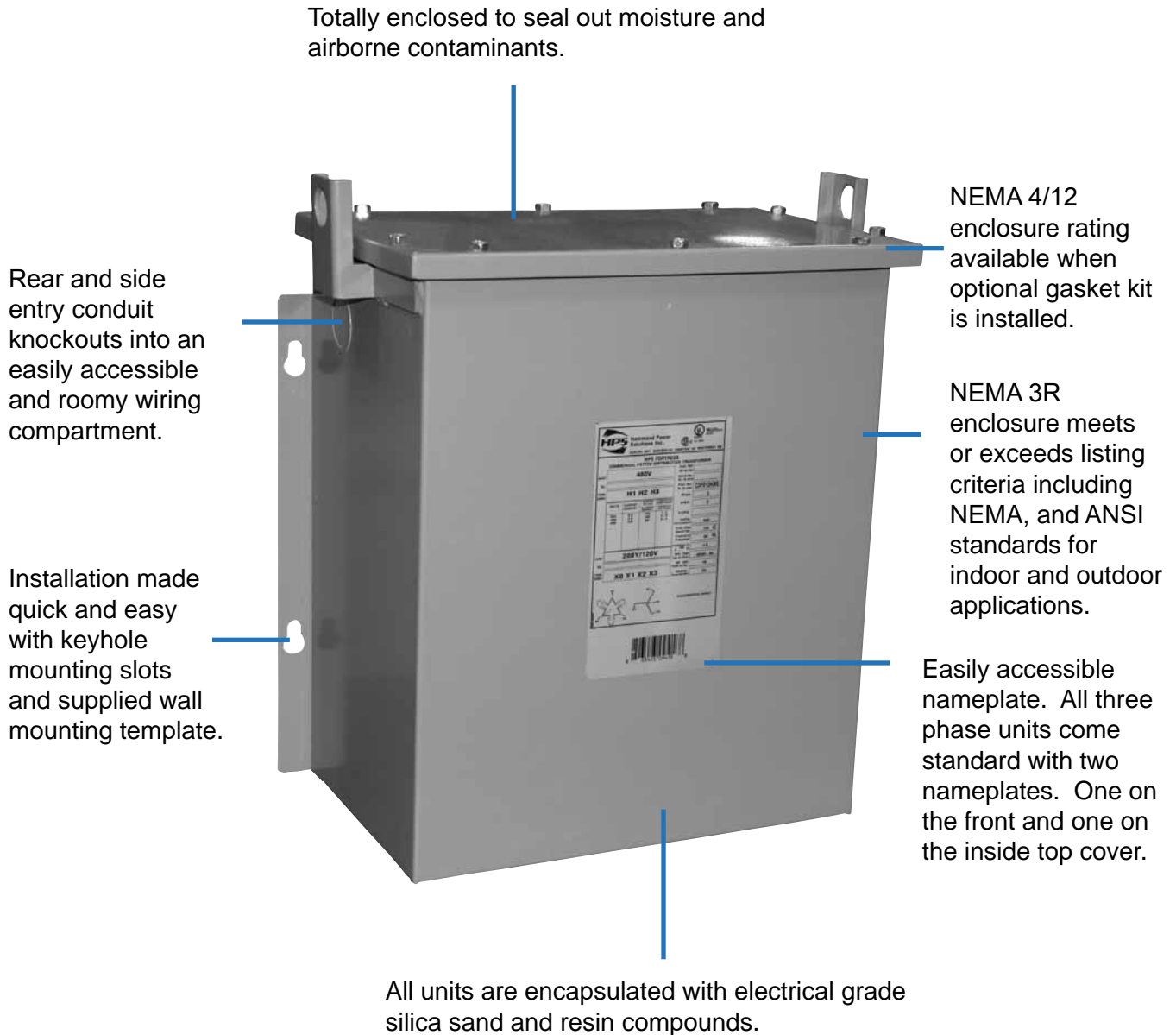

SECTION 8

Note: Picture displayed above is a standard three phase HPS Fortress units.



HPS FORTRESS™ COMMERCIAL ENCAPSULATED DISTRIBUTION TRANSFORMERS SINGLE PHASE STANDARD SPECIFICATIONS

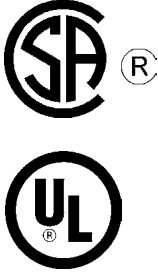

0.50 TO 1 KVA



1.5 TO 37.5 KVA



	.05 kVA to 1 kVA	1.5 kVA to 37.5 kVA
UL Listed	File: E50394	File: E50394
CSA Certified	File: LR3902	File: LR3902
Frequency	60 Hz (50/60 Hz)	60 Hz (50/60 Hz)
Insulation System	130°C standard on all units	180°C standard on all units.
Electrostatic Shield	Standard on 0.75 kVA and up.	Standard on all units.
Encapsulation	All units are encapsulated with electrical grade silica sand and resin compounds.	All units are encapsulated with electrical grade silica sand and resin compounds.
Enclosure Type	NEMA Type 3R	NEMA Type 3R
Enclosure Finish	ANSI 61 Grey, UL50	ANSI 61 Grey, UL50
Termination	Front accessible separate high and low voltage lead wires or copper tabs.	Front accessible separate high and low voltage lead wires or copper tabs.
Conduit Knock-Outs	Standard side and rear knock-outs on all units.	Standard side and rear knock-outs on all units.
Impedance	Typically 5 to 10%.	Typically 1 to 5%.
Mounting	Standard Wall Mounting.	Standard Wall Mounting up to 25kVA. Optional wall mounting kit for 37.5kVA units. Lifting provisions standard on units 5 kVA and up.
Sound Level	Meets NEMA ST-20 standards.	Meets NEMA ST-20 standards

Other voltages and kVA ratings not listed in this section are available upon request. Please contact customer service for details, price and availability.

SECTION 8

COMMERCIAL ENCAPSULATED

SINGLE PHASE, NEMA 3R STYLE ENCLOSURE



120 X 240 Primary Volts

120/240 Secondary Volts

60 Hz

kVA	Catalog Number	Case Style (Pages 260 - 267)	Approx. Dimensions (Inches)			Approx. Weight (Lbs.)	Mtg Type W - Wall F - Floor	Wiring Diagram (Pages 276 - 288)
			Width	Depth	Height			
0.05	C1FC05EE	NQ0	3.75	5.25	7.25	7	W	SCD1
0.10	C1FC10EE	NQ0	3.75	5.25	7.25	7	W	SCD1
0.15	C1FC15EE	NQ0	3.75	5.25	7.25	8	W	SCD1
0.25	C1FC25EE	NQ0	3.75	5.25	7.25	9	W	SCD1
0.35	C1FC35EE	NQ1	4.50	5.75	7.25	15	W	SCD1
0.50	C1FC50EE	NQ1	4.50	5.75	7.25	16	W	SCD1
0.75	C1FC75EES	NQ2	5.00	4.75	9.25	23	W	SCD1
1	C1F1C0EES	NQ3	5.88	5.50	10.50	24	W	SCD1
1.5	C1F1C5EES	NQ3	5.88	5.50	10.50	33	W	SCD1
2	C1F002EES	NQ4	7.00	6.50	11.75	42	W	SCD1
3	C1F003EES	NQ4	7.00	6.50	11.75	55	W	SCD1
5	C1F005EES	NQ5	10.00	7.75	17.25	96	W	SCD1
7.5	C1F007EES	NQ6A	12.25	9.25	17.63	148	W	SCD2
10	C1F010EES	NQ6	12.25	9.25	20.88	178	W	SCD2

208 X 416 Primary Volts

120/240 Secondary Volts

60 Hz

kVA	Catalog Number	Case Style (Pages 260 - 267)	Approx. Dimensions (Inches)			Approx. Weight (Lbs.)	Mtg Type W - Wall F - Floor	Wiring Diagram (Pages 276 - 288)
			Width	Depth	Height			
0.05	C1FC05GE	NQ0	3.75	5.25	7.25	7	W	SCD1
0.10	C1FC10GE	NQ0	3.75	5.25	7.25	7	W	SCD1
0.15	C1FC15GE	NQ0	3.75	5.25	7.25	8	W	SCD1
0.25	C1FC25GE	NQ0	3.75	5.25	7.25	9	W	SCD1
0.35	C1FC35GE	NQ1	4.50	5.75	7.25	15	W	SCD1
0.50	C1FC50GE	NQ1	4.50	5.75	7.25	16	W	SCD1
0.75	C1FC75GES	NQ2	5.00	4.75	9.25	23	W	SCD1
1	C1F1C0GES	NQ3	5.88	5.50	10.50	24	W	SCD1
1.5	C1F1C5GES	NQ3	5.88	5.50	10.50	33	W	SCD1
2	C1F002GES	NQ4	7.00	6.50	11.75	42	W	SCD1
3	C1F003GES	NQ4	7.00	6.50	11.75	55	W	SCD1
5	C1F005GES	NQ5	10.00	7.75	17.25	96	W	SCD1
7.5	C1F007GES	NQ6A	12.25	9.25	17.63	148	W	SCD2
10	C1F010GES	NQ6	12.25	9.25	20.88	178	W	SCD2

120/208/240/277 Primary Volts

120/240 Secondary Volts

60 Hz

kVA	Catalog Number	Case Style (Pages 260 - 267)	Approx. Dimensions (Inches)			Approx. Weight (Lbs.)	Mtg Type W - Wall F - Floor	Wiring Diagram (Pages 276 - 288)
			Width	Depth	Height			
0.05	C1FC05WE	NQ0	3.75	5.25	7.25	7	W	SCD41
0.10	C1FC10WE	NQ0	3.75	5.25	7.25	7	W	SCD41
0.15	C1FC15WE	NQ0	3.75	5.25	7.25	8	W	SCD41
0.25	C1FC25WE	NQ1	4.50	5.75	7.25	10	W	SCD41
0.35	C1FC35WE	NQ2	5.00	4.75	9.25	17	W	SCD41
0.50	C1FC50WE	NQ2	5.00	4.75	9.25	25	W	SCD41
0.75	C1FC75WES	NQ2	5.00	4.75	9.25	23	W	SCD41
1	C1F1C0WES	NQ3	5.88	5.50	10.50	24	W	SCD41
1.5	C1F1C5WES	NQ3	5.88	5.50	10.50	37	W	SCD41
2	C1F002WES	NQ4	7.00	6.50	11.75	52	W	SCD41
3	C1F003WES	NQ5	10.00	7.75	17.25	65	W	SCD2
5	C1F005WES	NQ5	10.00	7.75	17.25	108	W	SCD2
7.5	C1F007WES	NQ6	12.25	9.25	20.88	171	W	SCD2
10	C1F010WES	NQ6	12.25	9.25	20.88	183	W	SCD2

SECTION 8



SINGLE PHASE, NEMA 3R STYLE ENCLOSURE



240 X 480 Primary Volts

120/240 Secondary Volts

60 Hz

kVA	Catalog Number	Case Style (Pages 260 - 267)	Approx. Dimensions (Inches)			Approx. Weight (Lbs.)	Mtg Type W - Wall F - Floor	Wiring Diagram (Pages 276 - 288)
			Width	Depth	Height			
0.05	C1FC05LE	NQ0	3.75	5.25	7.25	7	W	SCD1
0.10	C1FC10LE	NQ0	3.75	5.25	7.25	7	W	SCD1
0.15	C1FC15LE	NQ0	3.75	5.25	7.25	8	W	SCD1
0.25	C1FC25LE	NQ0	4.50	5.75	7.25	9	W	SCD1
0.35	C1FC35LE	NQ1	4.50	5.75	7.25	15	W	SCD1
0.50	C1FC50LE	NQ1	4.50	5.75	7.25	16	W	SCD1
0.75	C1FC75LES	NQ2	5.00	4.75	9.25	23	W	SCD1
1	C1F1C0LES	NQ3	5.88	5.50	10.50	24	W	SCD1
1.5	C1F1C5LES	NQ3	5.88	5.50	10.50	33	W	SCD1
2	C1F002LES	NQ4	7.00	6.50	11.75	42	W	SCD1
3	C1F003LES	NQ4	7.00	6.50	11.75	55	W	SCD1
5	C1F005LES	NQ5	10.00	7.75	17.25	96	W	SCD1
7.5	C1F007LES	NQ6A	12.25	9.25	17.63	148	W	SCD2
10	C1F010LES	NQ6	12.25	9.25	20.88	179	W	SCD2
15	C1F015LES	NQ7	14.50	10.75	21.38	265	W	SCD2
25	C1F025LES	NQ8	14.50	10.75	27.38	385	W	SCD2
37.5	C1F037LES	NQS10	21.88	18.50	31.00	598	F or W*	SCD2

*OPTIONAL WALL MOUNTING KIT REQUIRED.
REFER TO PAGE 273 FOR DETAILS.

277 Primary Volts

120/240 Secondary Volts

50/60 Hz

kVA	Catalog Number	Case Style (Pages 260 - 267)	Approx. Dimensions (Inches)			Approx. Weight (Lbs.)	Mtg Type W - Wall F - Floor	Wiring Diagram (Pages 276 - 288)
			Width	Depth	Height			
0.05	C1FC05CE	NQ0	3.75	5.25	7.25	7	W	SCD4
0.10	C1FC10CE	NQ0	3.75	5.25	7.25	7	W	SCD4
0.15	C1FC15CE	NQ0	3.75	5.25	7.25	8	W	SCD4
0.25	C1FC25CE	NQ0	3.75	5.25	7.25	9	W	SCD4
0.35	C1FC35CE	NQ1	4.50	5.75	7.25	15	W	SCD4
0.50	C1FC50CE	NQ2	4.50	5.75	7.25	15	W	SCD4
0.75	C1FC75CES	NQ2	5.00	4.75	9.25	23	W	SCD4
1	C1F1C0CES	NQ3	5.88	5.50	10.50	24	W	SCD4
1.5	C1F1C5CES	NQ3	5.88	5.50	10.50	33	W	SCD4
2	C1F002CES	NQ4	7.00	6.50	11.75	42	W	SCD4
3	C1F003CES	NQ4	7.00	6.50	11.75	55	W	SCD4
5	C1F005CES	NQ5	10.00	7.75	17.25	96	W	SCD4
7.5	C1F007CES	NQ6A	12.25	9.25	17.63	148	W	SCD2
10	C1F010CES	NQ6	12.25	9.25	20.88	178	W	SCD2

277/480 Primary Volts

208/277 Secondary Volts

50/60 Hz

kVA	Catalog Number	Case Style (Pages 260 - 267)	Approx. Dimensions (Inches)			Approx. Weight (Lbs.)	Mtg Type W - Wall F - Floor	Wiring Diagram (Pages 276 - 288)
			Width	Depth	Height			
0.05	C1FC05HR	NQ0	3.75	5.25	7.25	7	W	SCD42
0.10	C1FC10HR	NQ0	3.75	5.25	7.25	8	W	SCD42
0.15	C1FC15HR	NQ0	3.75	5.25	7.25	11	W	SCD42
0.25	C1FC25HR	NQ1	4.50	5.75	7.25	12	W	SCD42
0.35	C1FC35HR	NQ2	5.00	4.75	9.25	15	W	SCD42
0.50	C1FC50HR	NQ2	5.00	4.75	9.25	18	W	SCD42
0.75	C1FC75HRS	NQ3	5.88	5.50	10.50	25	W	SCD42
1	C1F1C0HRS	NQ3	5.88	5.50	10.50	31	W	SCD42
1.5	C1F1C5HRS	NQ4	7.00	6.50	11.75	39	W	SCD42
2	C1F002HRS	NQ4	7.00	6.50	11.75	54	W	SCD42
3	C1F003HRS	NQ5	10.00	7.75	17.25	80	W	SCD43
5	C1F005HRS	NQ6	12.25	9.25	20.88	156	W	SCD43
7.5	C1F007HRS	NQ6	12.25	9.25	20.88	188	W	SCD43
10	C1F010HRS	NQ6	12.25	9.25	20.88	179	W	SCD43



SINGLE PHASE, NEMA 3R STYLE ENCLOSURE



347/380 Primary Volts **CE** 120/240 Secondary Volts

50/60 Hz

kVA	Catalog Number	Case Style (Pages 260 - 267)	Approx. Dimensions (Inches)			Approx. Weight (Lbs.)	Mtg Type W - Wall F - Floor	Wiring Diagram (Pages 276 - 288)
			Width	Depth	Height			
0.05	C1FC05JE	NQ0	3.75	5.25	7.25	7	W	SCD33
0.10	C1FC10JE	NQ0	3.75	5.25	7.25	7	W	SCD33
0.15	C1FC15JE	NQ0	3.75	5.25	7.25	8	W	SCD33
0.25	C1FC25JE	NQ0	3.75	5.25	7.25	9	W	SCD33
0.35	C1FC35JE	NQ1	4.50	5.75	7.25	14	W	SCD33
0.50	C1FC50JE	NQ1	4.50	5.75	7.25	14	W	SCD33
0.75	C1FC75JES	NQ2	5.00	4.75	9.25	23	W	SCD33
1	C1F1C0JES	NQ3	5.88	5.50	10.50	32	W	SCD33
1.5	C1F1C5JES	NQ3	5.88	5.50	10.50	35	W	SCD33
2	C1F002JES	NQ4	7.00	6.50	11.75	51	W	SCD33
3	C1F003JES	NQ5	10.00	7.75	17.25	89	W	SCD33
5	C1F005JES	NQ5	10.00	7.75	17.25	106	W	SCD44
7.5	C1F007JES	NQ6A	12.25	9.25	17.63	162	W	SCD44
10	C1F010JES	NQ6	12.25	9.25	20.88	194	W	SCD44

600 Primary Volts 120/240 Secondary Volts

60 Hz

kVA	Catalog Number	Case Style (Pages 260 - 267)	Approx. Dimensions (Inches)			Approx. Weight (Lbs.)	Mtg Type W - Wall F - Floor	Wiring Diagram (Pages 276 - 288)
			Width	Depth	Height			
0.05	C1FC05PE	NQ0	3.75	5.25	7.25	7	W	SCD4
0.10	C1FC10PE	NQ0	3.75	5.25	7.25	7	W	SCD4
0.15	C1FC15PE	NQ0	3.75	5.25	7.25	8	W	SCD4
0.25	C1FC25PE	NQ0	3.75	5.25	7.25	9	W	SCD4
0.35	C1FC35PE	NQ1	4.50	5.75	7.25	15	W	SCD4
0.50	C1FC50PE	NQ1	4.50	5.75	7.25	16	W	SCD4
0.75	C1FC75PES	NQ2	5.00	4.75	9.25	23	W	SCD4
1	C1F1C0PES	NQ3	5.88	5.50	10.50	24	W	SCD4
1.5	C1F1C5PES	NQ3	5.88	5.50	10.50	33	W	SCD4
2	C1F002PES	NQ4	7.00	6.50	11.75	42	W	SCD4
3	C1F003PES	NQ4	7.00	6.50	11.75	55	W	SCD4
5	C1F005PES	NQ5	10.00	7.75	17.25	96	W	SCD4
7.5	C1F007PES	NQ6A	12.25	9.25	17.63	148	W	SCD5
10	C1F010PES	NQ6	12.25	9.25	20.88	179	W	SCD5
15	C1F015PES	NQ7	14.50	10.75	21.38	265	W	SCD5
25	C1F025PES	NQ8	14.50	10.75	27.38	385	W	SCD5
37.5	C1F037PES	NQS10	21.88	18.50	31.00	598	F or W*	SCD5

*OPTIONAL WALL MOUNTING KIT REQUIRED. REFER TO PAGE 273 FOR DETAILS.

Export Model



190/200/208/220/240¹ X 380/400/416/440/480¹ Primary Volts 120/240 Secondary Volts 50/60 Hz

kVA	Catalog Number	Case Style (Pages 260 - 267)	Approx. Dimensions (Inches)			Approx. Weight (Lbs.)	Mtg Type W - Wall F - Floor	Wiring Diagram (Pages 276 - 288)
			Width	Depth	Height			
0.05	C1FC05XE	NQ0	3.75	5.25	7.25	7	W	SCD28
0.10	C1FC10XE	NQ0	3.75	5.25	7.25	7	W	SCD28
0.15	C1FC15XE	NQ0	3.75	5.25	7.25	9	W	SCD28
0.25	C1FC25XE	NQ0	3.75	5.25	7.25	10	W	SCD28
0.35	C1FC35XE	NQ1	4.50	5.75	7.25	15	W	SCD28
0.50	C1FC50XE	NQ1	4.50	5.75	7.25	16	W	SCD28
0.75	C1FC75XES	NQ2	5.00	4.75	9.25	24	W	SCD28
1	C1F1C0XES	NQ3	5.88	5.50	10.50	32	W	SCD28
1.5	C1F1C5XES	NQ4	7.00	6.50	11.75	37	W	SCD28
2	C1F002XES	NQ4	7.00	6.50	11.75	52	W	SCD28
3	C1F003XES	NQ5	10.00	7.75	17.25	89	W	SCD2
5	C1F005XES	NQ5	10.00	7.75	17.25	96	W	SCD2
7.5	C1F007XES	NQ6A	12.25	9.25	17.63	148	W	SCD2
10	C1F010XES	NQ6	12.25	9.25	20.88	179	W	SCD2

Note ¹: The primary voltage ratio of 240 or 480 is available at 60Hz only with a secondary voltage of approximately 130/262V.



HPS FORTRESS™

COMMERCIAL ENCAPSULATED DISTRIBUTION TRANSFORMERS THREE PHASE STANDARD SPECIFICATIONS

2 TO 5 KVA



6 TO 150 KVA



	2 kVA to 5 kVA	6 kVA to 150 kVA
UL Listed	File: E50394	File: E50394
CSA Certified	File: LR3902	File: LR3902
Frequency	60 Hz (50/60 Hz)	60 Hz (50/60 Hz)
Insulation System	130°C standard on all units.	180°C standard on all units.
Electrostatic Shield	Standard on all units.	Standard on all units.
Encapsulation	All units are encapsulated with electrical grade silica sand and resin compounds.	All units are encapsulated with electrical grade silica sand and resin compounds.
Enclosure Type	NEMA Type 3R	NEMA Type 3R
Enclosure Finish	ANSI 61 Grey, UL50	ANSI 61 Grey, UL50
Termination	Top accessible separate high and low voltage lead wires or copper tabs.	Top accessible separate high and low voltage lead wires or copper tabs.
Conduit Knock-Outs	Standard side and rear knock-outs on all units.	Standard side and rear knock-outs on all units.
Impedance	Typically 4 to 8%	Typically 1 to 5%.
Mounting	Standard Wall Mounting Lifting provisions standard on all units.	Standard Wall Mounting up to 15 kVA. (Optional wall mounting kit available for 15 kVA, 30 kVA and 45 kVa.) Floor mount only over 45 kVA. Lifting provisions standard 6 kVA to 150 kVA.
Sound Level	Meets NEMA ST-20 standards.	Meets NEMA ST-20 standards.

Other voltages and kVA ratings not listed in this section are available upon request. Please contact customer service for details, price and availability.

THREE PHASE, NEMA 3R STYLE ENCLOSURE



208 Primary Volts

208Y/120 Secondary Volts

60 Hz

kVA	Catalog Number	Case Style (Pages 260 - 267)	Approx. Dimensions (Inches)			Approx. Weight (Lbs.)	Mtg Type W - Wall F - Floor	Wiring Diagram (Pages 276 - 288)
			Width	Depth	Height			
2	C3F002BBS	NQT3	12.38	5.44	11.13	50	W	SCD8
3	C3F003BBS	NQT3	12.38	5.44	11.13	70	W	SCD8
6	C3F006BBS	NQT5	16.63	10.25	16.63	140	W	SCD8
9	C3F009BBS	NQT6	19.25	10.44	16.63	210	W	SCD8
15	C3F015BBS	NQT7	20.25	13.00	23.38	350	F or W*	SCD8
30	C3F030BBS	NQT8	22.25	13.00	28.38	525	F or W*	SCD9
45	C3F045BBS	NQT9	31.50	16.00	29.88	700	F or W*	SCD9
75	C3F075BBS	NQT9A	34.63	18.50	36.75	1420	F	SCD9

*OPTIONAL WALL MOUNTING KIT REQUIRED.
REFER TO PAGE 273 FOR DETAILS.

208 Primary Volts

480Y/277 Secondary Volts

60 Hz

kVA	Catalog Number	Case Style (Pages 260 - 267)	Approx. Dimensions (Inches)			Approx. Weight (Lbs.)	Mtg Type W - Wall F - Floor	Wiring Diagram (Pages 276 - 288)
			Width	Depth	Height			
2	C3F002BKS	NQT3	12.38	5.44	11.13	50	W	SCD23
3	C3F003BKS	NQT3	12.38	5.44	11.13	70	W	SCD23
6	C3F006BKS	NQT5	16.63	10.25	16.63	140	W	SCD23
9	C3F009BKS	NQT6	19.25	10.44	16.63	210	W	SCD23
15	C3F015BKS	NQT7	20.25	13.00	23.38	350	F or W*	SCD23
30	C3F030BKS	NQT8	22.25	13.00	28.38	525	F or W*	SCD26
45	C3F045BKS	NQT9	31.50	16.00	29.88	700	F or W*	SCD26
75	C3F075BKS	NQT9A	34.63	18.50	36.75	1420	F	SCD26

*OPTIONAL WALL MOUNTING KIT REQUIRED.
REFER TO PAGE 273 FOR DETAILS.

240 Primary Volts

208Y/120 Secondary Volts

60 Hz

kVA	Catalog Number	Case Style (Pages 260 - 267)	Approx. Dimensions (Inches)			Approx. Weight (Lbs.)	Mtg Type W - Wall F - Floor	Wiring Diagram (Pages 276 - 288)
			Width	Depth	Height			
2	C3F002DBS	NQT3	12.38	5.44	11.13	50	W	SCD8
3	C3F003DBS	NQT3	12.38	5.44	11.13	70	W	SCD8
6	C3F006DBS	NQT5	16.63	10.25	16.63	140	W	SCD8
9	C3F009DBS	NQT6	19.25	10.44	16.63	210	W	SCD8
15	C3F015DBS	NQT7	20.25	13.00	23.38	350	F or W*	SCD8
30	C3F030DBS	NQT8	22.25	13.00	28.38	525	F or W*	SCD9
45	C3F045DBS	NQT9	31.50	16.00	29.88	700	F or W*	SCD9
75	C3F075DBS	NQT9A	34.63	18.50	36.75	1420	F	SCD9

*OPTIONAL WALL MOUNTING KIT REQUIRED.
REFER TO PAGE 273 FOR DETAILS.

240 Primary Volts

480Y/277 Secondary Volts

60 Hz

kVA	Catalog Number	Case Style (Pages 260 - 267)	Approx. Dimensions (Inches)			Approx. Weight (Lbs.)	Mtg Type W - Wall F - Floor	Wiring Diagram (Pages 276 - 288)
			Width	Depth	Height			
2	C3F002DKS	NQT3	12.38	5.44	11.13	50	W	SCD23
3	C3F003DKS	NQT3	12.38	5.44	11.13	70	W	SCD23
6	C3F006DKS	NQT5	16.63	10.25	16.63	140	W	SCD23
9	C3F009DKS	NQT6	19.25	10.44	16.63	210	W	SCD23
15	C3F015DKS	NQT7	20.25	13.00	23.38	350	F or W*	SCD23
30	C3F030DKS	NQT8	22.25	13.00	28.38	525	F or W*	SCD26
45	C3F045DKS	NQT9	31.50	16.00	29.88	700	F or W*	SCD26
75	C3F075DKS	NQT9A	34.63	18.50	36.75	1420	F	SCD26

*OPTIONAL WALL MOUNTING KIT REQUIRED.
REFER TO PAGE 273 FOR DETAILS.



THREE PHASE, NEMA 3R STYLE ENCLOSURE



480 Primary Volts

208Y/120 Secondary Volts

60 Hz

kVA	Catalog Number	Case Style (Pages 260 - 267)	Approx. Dimensions (Inches)			Approx. Weight (Lbs.)	Mtg Type W - Wall F - Floor	Wiring Diagram (Pages 276 - 288)
			Width	Depth	Height			
2	C3F002KBS	NQT3	12.38	5.44	11.13	50	W	SCD8
3	C3F003KBS	NQT3	12.38	5.44	11.13	70	W	SCD8
6	C3F006KBS	NQT5	16.63	10.25	16.63	140	W	SCD8
9	C3F009KBS	NQT6	19.25	10.44	16.63	210	W	SCD8
15	C3F015KBS	NQT7	20.25	13.00	23.38	350	F or W*	SCD8
30	C3F030KBS	NQT8	22.25	13.00	28.38	525	F or W*	SCD9
45	C3F045KBS	NQT9	31.50	16.00	29.88	700	F or W*	SCD9
75	C3F075KBS	NQT9A	34.63	18.50	36.75	1420	F	SCD9

*OPTIONAL WALL MOUNTING KIT REQUIRED.
REFER TO PAGE 273 FOR DETAILS.

480 Primary Volts

240D Secondary Volts

60 Hz

kVA	Catalog Number	Case Style (Pages 260 - 267)	Approx. Dimensions (Inches)			Approx. Weight (Lbs.)	Mtg Type W - Wall F - Floor	Wiring Diagram (Pages 276 - 288)
			Width	Depth	Height			
2	C3F002KDS	NQT3	12.38	5.44	11.13	50	W	SCD12
3	C3F003KDS	NQT3	12.38	5.44	11.13	70	W	SCD12
6	C3F006KDS	NQT5	16.63	10.25	16.63	140	W	SCD12
9	C3F009KDS	NQT6	19.25	10.44	16.63	210	W	SCD12
15	C3F015KDS	NQT7	20.25	13.00	23.38	350	F or W*	SCD12
30	C3F030KDS	NQT8	22.25	13.00	28.38	525	F or W*	SCD38
45	C3F045KDS	NQT9	31.50	16.00	29.88	700	F or W*	SCD38
75	C3F075KDS	NQT9A	34.63	18.50	36.75	1420	F	SCD38

*OPTIONAL WALL MOUNTING KIT REQUIRED.
REFER TO PAGE 273 FOR DETAILS.

600 Primary Volts

208Y/120 Secondary Volts

60 Hz

kVA	Catalog Number	Case Style (Pages 260 - 267)	Approx. Dimensions (Inches)			Approx. Weight (Lbs.)	Mtg Type W - Wall F - Floor	Wiring Diagram (Pages 276 - 288)
			Width	Depth	Height			
2	C3F002PBS	NQT3	12.38	5.44	11.13	50	W	SCD8
3	C3F003PBS	NQT3	12.38	5.44	11.13	70	W	SCD8
6	C3F006PBS	NQT5	16.63	10.25	16.63	140	W	SCD8
9	C3F009PBS	NQT6	19.25	10.44	16.63	210	W	SCD8
15	C3F015PBS	NQT7	20.25	13.00	23.38	350	F or W*	SCD8
30	C3F030PBS	NQT8	22.25	13.00	28.38	525	F or W*	SCD9
45	C3F045PBS	NQT9	31.50	16.00	29.88	700	F or W*	SCD9
75	C3F075PBS	NQT9A	34.63	18.50	36.75	1420	F	SCD9

*OPTIONAL WALL MOUNTING KIT REQUIRED.
REFER TO PAGE 273 FOR DETAILS.

600 Primary Volts

240D Secondary Volts

60 Hz

kVA	Catalog Number	Case Style (Pages 260 - 267)	Approx. Dimensions (Inches)			Approx. Weight (Lbs.)	Mtg Type W - Wall F - Floor	Wiring Diagram (Pages 276 - 288)
			Width	Depth	Height			
2	C3F002PDS	NQT3	12.38	5.44	11.13	50	W	SCD12
3	C3F003PDS	NQT3	12.38	5.44	11.13	70	W	SCD12
6	C3F006PDS	NQT5	16.63	10.25	16.63	140	W	SCD12
9	C3F009PDS	NQT6	19.25	10.44	16.63	210	W	SCD12
15	C3F015PDS	NQT7	20.25	13.00	23.38	350	F or W*	SCD12
30	C3F030PDS	NQT8	22.25	13.00	28.38	525	F or W*	SCD45
45	C3F045PDS	NQT9	31.50	16.00	29.88	700	F or W*	SCD45
75	C3F075PDS	NQT9A	34.63	18.50	36.75	1420	F	SCD45

*OPTIONAL WALL MOUNTING KIT REQUIRED.
REFER TO PAGE 273 FOR DETAILS.



HPS TITAN® Applications

HPS has over 90 years of experience in the design and manufacture of dry-type transformers including those for harsh environments and hazardous location applications.

The terms “Harsh Environments” and “Hazardous Location” in many industries brings to the forefront the many difficult environments which may contain dangerous gases, liquids, dust, etc., that could lead to serious consequences. Products which are designed to operate in these hazardous environmental conditions must be safe, reliable and affordable.

HPS is the leader in the industry by our investment in providing a complete solution.

- **Advanced Encapsulated Harsh Environment and Hazardous Location Transformer Designs**
- **Standard Features Expected in the Industry**
- **Superior Quality in Materials and Workmanship**
- **Options and Accessories that Enhance the Product Line**
- **Value, Customer Service and Support**

The **HPS TITAN** line of encapsulated transformers have been designed for installation where safety is your priority, efficiency is a concern and the environment, location and application are key. Typical applications include institutional, industrial, petrochemical, marine, mining etc. HPS designs provide:

- **Safe Superior Performance**
- **Compact Efficient Design**
- **Easy Installation and Hook-up**

HPS TITAN series transformers are *UL Listed* for “**Class 1, Division 2, Groups A, B, C and D Hazardous Locations**” and are *ABS Type Approved* for “**Marine Duty Service and Offshore Applications - Electrical Distribution and Propulsion**”. A North American Temperature Classification of **T3C**, the **HPS TITAN** series will remain cool under load.

The **HPS TITAN** series of products are competitively priced for the rugged industrial and indoor and outdoor distribution transformer applications. HPS facilities have the most modern testing equipment for the requirements of ANSI, OSHA, UL, CSA, IEC, NEMA, ABS, DNV, BV, CE, etc.

Hammond Power Solutions . . . helping customers solve tough applications in today’s environments!



HPS TITAN® Features and Benefits

- **Ratings:** Single phase from 0.50 kVA thru to 37.5 kVA; three phase from 2 kVA thru to 150 kVA
- **Approvals:** UL 1604 - File No. E258346 (Class 1, Division 2, Groups A, B, C and D Hazardous Locations)
ABS Type Approval - Certificate No. 04-HS435190/1-PDA (Marine Duty Service and Offshore Applications)
- **Electrostatic Shield:** Standard on single phase units over 0.50 kVA and all three phase units; provides quality power and superior protection.
- **Quality Design:** All units are encapsulated with electrical grade silica sand and resin compounds which completely enclose the core and coil to seal out moisture, airborne contaminants and eliminates corrosion and deterioration.
- **Insulation:** Offering UL class 130°C insulation, 80°C temperature rise up to 1 kVA on single phase and 5 kVA on three phase; 180°C insulation, 115°C temperature rise on all single phase units over 1 kVA and 5 kVA three phase units. Quiet operation with sound levels below NEMA standards.
- **Enclosures:** NEMA 3R enclosures meet or exceed listing criteria including NEMA, ANSI, ABS and OSHA standards for indoor and outdoor service. On three phase units, convert to a NEMA 4 or 12 enclosure rating quickly and easily by ordering the HPS NEMA 4/12 Gasket Kit. Competitively priced stainless steel enclosures with stainless steel nameplates are also available.
- **Conduit knockouts:** Rear and side entry into an easily accessible and roomy wiring compartment.
- **Wiring compartment:** Provides copper lead wire terminations or copper tab and standard ground lug assembly for easy cable installation.
- **Installation made quick and easy:** Via keyhole mounting slots. Wall mounting available on all single phase units and three phase from 2 kVA to 15 kVA (excluding Q015QKKF). Lifting provisions are standard on single phase from 5 to 37.5 kVA and three phase units from 6 to 150 kVA.
- **Dual Nameplates:** All three phase units come standard with two nameplates. One on the front and an additional nameplate is located on the inside of the top cover. (1ph units have one standard nameplate only.)
- **Additional voltage groups and kVA sizes** are available upon request.
- **Warranty:** All HPS standard catalog encapsulated transformers come with a 10 year limited* warranty. *(Please refer to the Hammond Power Solutions "standard Catalog Transformer Products Warranty for details)

HPS TITAN Single Phase



HPS TITAN Three Phase



HPS TITAN[®] TRANSFORMERS FOR HARSH ENVIRONMENTS AND HAZARDOUS LOCATIONS

SINGLE PHASE STANDARD SPECIFICATIONS

0.50 TO 1 KVA



1.5 TO 37.5 KVA



	0.50 kVA to 1 kVA	1.5 kVA to 37.5 kVA
UL 1604, Class I, Division 2	File: E258346	File: E258346
ABS Type Approval (RQS)	Certificate No.: 04-HS435190/1-PDA	Certificate No.: 04-HS435190/1-PDA
Frequency	60 Hz (50/60 Hz on units with 380V primary)	60 Hz (50/60 Hz on units with 380V primary)
Insulation System	130°C (80°C rise) standard on all units.	180°C (115°C rise) standard on all units. Optional 130°C (80°C rise) available.
Electrostatic Shield	Optional on 0.50 kVA. Standard on 0.75 kVA and 1 kVA.	Standard on all units.
Encapsulation	All units are encapsulated with electrical grade silica sand and resin compounds.	All units are encapsulated with electrical grade silica sand and resin compounds.
Enclosure Type	Heavy Duty NEMA Type 3R Optional NEMA 4, 4X (stainless steel) and 12	Heavy Duty NEMA Type 3R Optional NEMA 4, 4X (stainless steel) and 12
Enclosure Finish	ANSI 61 Grey, UL50	ANSI 61 Grey, UL50
Termination	Front accessible separate high and low voltage lead wires or copper tabs.	Front accessible separate high and low voltage lead wires or copper tabs.
Conduit Knock-Outs	Standard side and rear knock-outs on all units.	Standard side and rear knock-outs on all units.
Impedance	Typically 5 to 10% on 0.50 kVA. Typically 1 to 5% on 0.75 kVA and 1 kVA	Typically 1 to 5%.
Mounting	Standard Wall Mounting Lifting provisions standard on all units.	Standard Wall Mounting Lifting provisions standard on units.
Seismic	Seismically certified in accordance with 2009 IBC for SDS <= 2.00g, z/h = 1.0 and IP = 1.5	Seismically certified in accordance with 2009 IBC for SDS <= 2.00g, z/h = 1.0 and IP = 1.5
Sound Level	Meets NEMA ST-20 standards. (Optional low noise units available on request)	Meets NEMA ST-20 standards. (Optional low noise units available on request)

Other voltages and kVA ratings not listed in this section are available upon request. Please contact customer service for details, price and availability.

All HPS TITAN single phase transformers are UL Listed for "Class 1, Division 2, Groups A, B, C and D Hazardous Locations" and are ABS Type Approved for "Marine Duty Service and Offshore Applications - Electrical Distribution and Propulsion". And with a North American Temperature Classification of T3C, the HPS TITAN series will remain cool under load.



SINGLE PHASE, NEMA 3R STYLE ENCLOSURE



208/240/277 Primary Volts

120/240 Secondary Volts

60 Hz

kVA	Catalog Number	Case Style (Pages 260 - 267)	Approx. Dimensions (Inches)			Approx. Weight (Lbs.)	Mtg Type W - Wall F - Floor	Wiring Diagram (Pages 276 - 288)
			Width	Depth	Height			
0.50	QC50YECB	NQ2	5.00	4.75	9.25	19	W	SCD 18
0.75	QC75YEKB	NQ2	5.00	4.75	9.25	21	W	SCD 18
1	Q1C0YEKB	NQ3	5.88	5.50	10.50	28	W	SCD 18
1.5	Q1C5YEKF	NQ3	5.88	5.50	10.50	36	W	SCD 18
2	Q002YEKF	NQ4	7.00	6.50	11.75	44	W	SCD 18
3	Q003YEKF	NQ4	7.00	6.50	11.75	56	W	SCD 18
5	Q005YEKF	NQ5	10.00	7.75	17.25	134	W	SCD 6
7.5	Q007YEKF	NQ5	10.00	7.75	17.25	160	W	SCD 6
10	Q010YEKF	NQ6	12.25	9.25	20.88	204	W	SCD 6
15	Q015YEKF	NQ6	12.25	9.25	20.88	248	W	SCD 6
25	Q025YEKF	NQ7	14.50	10.75	21.38	345	W	SCD 6
37.5	Q037YEKF	NQ8	14.50	10.75	27.38	476	W	SCD 6

For shielded 0.50 kVA units, replace the suffix "CB" with a "KB".

347/380 Primary Volts



120/240 Secondary Volts

50/60 Hz

kVA	Catalog Number	Case Style (Pages 260 - 267)	Approx. Dimensions (Inches)			Approx. Weight (Lbs.)	Mtg Type W - Wall F - Floor	Wiring Diagram (Pages 276 - 288)
			Width	Depth	Height			
0.50	QC50FECB	NQ2	5.00	4.75	9.25	18	W	SCD 33
0.75	QC75FEKB	NQ2	5.00	4.75	9.25	20	W	SCD 33
1	Q1C0FEKB	NQ3	5.88	5.50	10.50	26	W	SCD 33
1.5	Q1C5FEKF	NQ3	5.88	5.50	10.50	36	W	SCD 33
2	Q002FEKF	NQ4	7.00	6.50	11.75	55	W	SCD 33
3	Q003FEKF	NQ5	10.00	7.75	17.25	88	W	SCD 44
5	Q005FEKF	NQ5	10.00	7.75	17.25	130	W	SCD 44
7.5	Q007FEKF	NQ6	12.25	9.25	20.88	145	W	SCD 44
10	Q010FEKF	NQ6	12.25	9.25	20.88	155	W	SCD 44
15	Q015FEKF	NQ6	12.25	9.25	20.88	248	W	SCD 44
25	Q025FEKF	NQ7	14.50	10.75	21.38	345	W	SCD 44
37.5	Q037FEKF	NQ8	14.50	10.75	27.38	476	W	SCD 48

For shielded 0.50 kVA units, replace the suffix "CB" with a "KB".

240 X 480 Primary Volts

120/240 Secondary Volts

60 Hz

kVA	Catalog Number	Case Style (Pages 260 - 267)	Approx. Dimensions (Inches)			Approx. Weight (Lbs.)	Mtg Type W - Wall F - Floor	Wiring Diagram (Pages 276 - 288)
			Width	Depth	Height			
0.50	QC50LECB	NQ2	5.00	4.75	9.25	23	W	SCD 1
0.75	QC75LEKB	NQ2	5.00	4.75	9.25	24	W	SCD 1
1	Q1C0LEKB	NQ3	5.88	5.50	10.50	28	W	SCD 1
1.5	Q1C5LEKF	NQ3	5.88	5.50	10.50	35	W	SCD 1
2	Q002LEKF	NQ4	7.00	6.50	11.75	47	W	SCD 1
3	Q003LEKF	NQ4	7.00	6.50	11.75	62	W	SCD 1
5	Q005LEKF	NQ5	10.00	7.75	17.25	131	W	SCD 1
7.5	Q007LEKF	NQ5	10.00	7.75	17.25	155	W	SCD 2
10	Q010LEKF	NQ6	12.25	9.25	20.88	220	W	SCD 2
15	Q015LEKF	NQ6	12.25	9.25	20.88	248	W	SCD 2
25	Q025LEKF	NQ7	14.50	10.75	21.38	345	W	SCD 2
37.5	Q037LEKF	NQ8	14.50	10.75	27.38	476	W	SCD 2

For shielded 0.50 kVA units, replace the suffix "CB" with a "KB".

SECTION 8





600 Primary Volts

120/240 Secondary Volts

60 Hz

kVA	Catalog Number	Case Style (Pages 260 - 267)	Approx. Dimensions (Inches)			Approx. Weight (Lbs.)	Mtg Type W - Wall F - Floor	Wiring Diagram (Pages 276 - 288)
			Width	Depth	Height			
0.50	QC50PECB	NQ2	5.00	4.75	9.25	15	W	SCD 4
0.75	QC75PEKB	NQ2	5.00	4.75	9.25	18	W	SCD 4
1	Q1C0PEKB	NQ3	5.88	5.50	10.50	27	W	SCD 4
1.5	Q1C5PEKF	NQ3	5.88	5.50	10.50	31	W	SCD 4
2	Q002PEKF	NQ4	7.00	6.50	11.75	40	W	SCD 4
3	Q003PEKF	NQ4	7.00	6.50	11.75	52	W	SCD 4
5	Q005PEKF	NQ5	10.00	7.75	17.25	114	W	SCD 4
7.5	Q007PEKF	NQ5	10.00	7.75	17.25	129	W	SCD 5
10	Q010PEKF	NQ6	12.25	9.25	20.88	197	W	SCD 5
15	Q015PEKF	NQ6	12.25	9.25	20.88	234	W	SCD 5
25	Q025PEKF	NQ7	14.50	10.75	21.38	285	W	SCD 6
37.5	Q037PEKF	NQ8	14.50	10.75	27.38	454	W	SCD 6

For shielded 0.50 kVA units, replace the suffix "CB" with a "KB".

Export Model

190/200/208/220/240¹ X 380/400/415/440/480¹ Primary Volts 120/240 Secondary Volts 50/60 Hz

kVA	Catalog Number	Case Style (Pages 260 - 267)	Approx. Dimensions (Inches)			Approx. Weight (Lbs.)	Mtg Type W - Wall F - Floor	Wiring Diagram (Pages 276 - 288)
			Width	Depth	Height			
0.50	QC50XECB	NQ2	5.00	4.75	9.25	15	W	SCD 28
0.75	QC75XEKB	NQ2	5.00	4.75	9.25	20	W	SCD 28
1	Q1C0XEKB	NQ3	5.88	5.50	10.50	32	W	SCD 28
1.5	Q1C5XEKF	NQ3	5.88	5.50	10.50	35	W	SCD 28
2	Q002XEKF	NQ4	7.00	6.50	11.75	54	W	SCD 28
3	Q003XEKF	NQ4	7.00	6.50	11.75	65	W	SCD 2
5	Q005XEKF	NQ5	10.00	7.75	17.25	138	W	SCD 2
7.5	Q007XEKF	NQ6	12.25	9.25	20.88	189	W	SCD 2
10	Q010XEKF	NQ6	12.25	9.25	20.88	222	W	SCD 2
15	Q015XEKF	NQ7	14.5	10.75	21.38	300	W	SCD 2
25	Q025XEKF							CONSULT FACTORY
37.5	Q037XEKF							CONSULT FACTORY

For shielded 0.50 kVA units, replace the suffix "CB" with a "KB".

The above export model units carry the CE Mark.

Note ¹: The primary voltage ratio of 240 or 480 is available at 60Hz only with a secondary voltage of approximately 130/262V.

SECTION 8



HPS TITAN TRANSFORMERS FOR HARSH ENVIRONMENTS AND HAZARDOUS LOCATIONS

THREE PHASE STANDARD SPECIFICATIONS

2 TO 5 KVA



6 TO 150 KVA



	2 kVA to 5 kVA	6 kVA to 150 kVA
UL 1604, Class I, Division 2	File: E258346	File: E258346
ABS Type Approval (RQS)	Certificate No.: 04-HS435190/1-PDA	Certificate No.: 04-HS435190/1-PDA
Frequency	60 Hz (50/60 Hz on units with 380V primary)	60 Hz (50/60 Hz on units with 380V primary)
Insulation System	130°C (80°C rise) standard on all units.	180°C (115°C rise) standard on all units. Optional 130°C (80°C rise) available.
Electrostatic Shield	Standard on all units.	Standard on all units.
Encapsulation	All units are encapsulated with electrical grade silica sand and resin compounds.	All units are encapsulated with electrical grade silica sand and resin compounds.
Enclosure Type	Heavy Duty NEMA Type 3R Optional NEMA 4, 4X (stainless steel) and 12	Heavy Duty NEMA Type 3R Optional NEMA 4, 4X (stainless steel) and 12
Enclosure Finish	ANSI 61 Grey, UL50	ANSI 61 Grey, UL50
Termination	Top accessible separate high and low voltage lead wires or copper tabs.	Top accessible separate high and low voltage lead wires or copper tabs.
Conduit Knock-Outs	Standard side and rear knock-outs on all units.	Standard side and rear knock-outs on all units.
Impedance	Typically 1 to 5%.	Typically 1 to 5%.
Mounting	Standard Wall Mounting.	Standard Wall Mounting up to 15 kVA (Optional wall mounting kit available for 30 kVA and 45 kVA). Floor Mount only over 45 kVA. Lifting provisions standard 6 kVA to 150 kVA.
Seismic	Seismically certified in accordance with 2009 IBC for SDS <= 2.00g, z/h = 1.0 and IP = 1.5	Seismically certified in accordance with 2009 IBC for SDS <= 2.00g, z/h = 1.0 and IP = 1.5
Sound Level	Meets NEMA ST-20 standards. (Optional low noise units available on request)	Meets NEMA ST-20 standards. (Optional low noise units available on request)

Other voltages and kVA ratings not listed in this section are available upon request. Please contact customer service for details, price and availability.

All HPS TITAN three phase transformers are UL Listed for "Class 1, Division 2, Groups A, B, C and D Hazardous Locations" and are ABS Type Approved for "Marine Duty Service and Offshore Applications - Electrical Distribution and Propulsion". And with a North American Temperature Classification of T3C, the HPS TITAN series will remain cool under load.



SECTION 8

INDUSTRIAL ENCAPSULATED

THREE PHASE, NEMA 3R STYLE ENCLOSURE



480 Delta Primary Volts

208Y/120 Secondary Volts

60 Hz

kVA	Catalog Number	Case Style (Pages 260 - 267)	Approx. Dimensions (Inches)			Approx. Weight (Lbs.)	Mtg Type W - Wall F - Floor	Wiring Diagram (Pages 276 - 288)
			Width	Depth	Height			
2	P002KBKB	NQT3	12.38	5.44	12.39	49	W	SCD 8
3	P003KBKB	NQT3	12.38	5.44	12.39	86	W	SCD 8
6	P006KBKF	NQT4	15.19	6.94	16.39	160	W	SCD 8
9	P009KBKF	NQT5	16.63	10.25	17.89	262	W	SCD 8
15	P015KBKF	NQT6	19.25	10.44	17.89	304	W	SCD 7
30	P030KBKF	NQT7	20.25	13.00	23.38	478	F or W*	SCD 19
45	P045KBKF	NQT8	22.25	13.00	28.38	642	F or W*	SCD 19
75	P075KBKF	NQT9	31.25	16.00	29.88	1450	F	SCD 19
112.5	P112KBKF	NQT10	38.44	26.00	39.13	2100	F	SCD 19
150	P150KBKF	NQT11	37.38	30.00	45.63	2650	F	SCD 19

*OPTIONAL WALL MOUNTING KIT REQUIRED.
REFER TO PAGE 273 FOR DETAILS.

480 Delta Primary Volts

240 Delta Secondary Volts

60 Hz

kVA	Catalog Number	Case Style (Pages 260 - 267)	Approx. Dimensions (Inches)			Approx. Weight (Lbs.)	Mtg Type W - Wall F - Floor	Wiring Diagram (Pages 276 - 288)
			Width	Depth	Height			
2	P002KDKB	NQT3	12.38	5.44	12.39	52	W	SCD 12
3	P003KDKB	NQT3	12.38	5.44	12.39	68	W	SCD 12
6	P006KDKF	NQT4	15.19	6.94	16.39	182	W	SCD 12
9	P009KDKF	NQT5	16.63	10.25	17.89	250	W	SCD 37
15	P015KDKF	NQT6	19.25	10.44	17.89	312	W	SCD 37
30	P030KDKF	NQT7	20.25	13.00	23.38	540	F or W*	SCD 38
45	P045KDKF	NQT8	22.25	13.00	28.38	650	F or W*	SCD 38
75	P075KDKF	NQT9	31.25	16.00	29.88	1230	F	SCD 38
112.5	P112KDKF	NQT10	38.44	26.00	39.13	2100	F	SCD 38
150	P150KDKF	NQT11	37.38	30.00	45.63	2650	F	SCD 38

*OPTIONAL WALL MOUNTING KIT REQUIRED.
REFER TO PAGE 273 FOR DETAILS.

600 Delta Primary Volts

208Y/120 Secondary Volts

60 Hz

kVA	Catalog Number	Case Style (Pages 260 - 267)	Approx. Dimensions (Inches)			Approx. Weight (Lbs.)	Mtg Type W - Wall F - Floor	Wiring Diagram (Pages 276 - 288)
			Width	Depth	Height			
2	P002PBKB	NQT3	12.38	5.44	12.39	85	W	SCD 8
3	P003PBKB	NQT3	12.38	5.44	12.39	94	W	SCD 8
6	P006PBKF	NQT4	15.19	6.94	16.39	146	W	SCD 8
9	P009PBKF	NQT5	16.63	10.25	17.89	211	W	SCD 9
15	P015PBKF	NQT6	19.25	10.44	17.89	340	W	SCD 9
30	P030PBKF	NQT7	20.25	13.00	23.38	605	F or W*	SCD 9
45	P045PBKF	NQT8	22.25	13.00	28.38	770	F or W*	SCD 9
75	P075PBKF	NQT9	31.25	16.00	29.88	1350	F	SCD 9
112.5	P112PBKF	NQT10	38.44	26.00	39.13	3150	F	SCD 9
150	P150PBKF	NQT11	37.38	30.00	45.63	3200	F	SCD 9

*OPTIONAL WALL MOUNTING KIT REQUIRED.
REFER TO PAGE 273 FOR DETAILS.

SECTION 8



THREE PHASE, NEMA 3R STYLE ENCLOSURE



600 Wye Primary Volts

240 Delta Secondary Volts

60 Hz

kVA	Catalog Number	Case Style (Pages 260 - 267)	Approx. Dimensions (Inches)			Approx. Weight (Lbs.)	Mtg Type W - Wall F - Floor	Wiring Diagram (Pages 276 - 288)
			Width	Depth	Height			
2	P002PDKB	NQT3	12.38	5.44	12.39	51	W	SCD 27
3	P003PDKB	NQT3	12.38	5.44	12.39	68	W	SCD 27
6	P006PDKF	NQT4	15.19	6.94	16.39	146	W	SCD 27
9	P009PDKF	NQT5	16.63	10.25	17.89	211	W	SCD 29
15	P015PDKF	NQT6	19.25	10.44	17.89	270	W	SCD 29
30	P030PDKF	NQT7	20.25	13.00	23.38	515	F or W*	SCD 16
45	P045PDKF	NQT8	22.25	13.00	28.38	740	F or W*	SCD 16
75	P075PDKF	NQT9	31.25	16.00	29.88	CF	F	SCD 16
112.5	P112PDKF	NQT10	38.44	26.00	39.13	CF	F	SCD 16
150	P150PDKF	NQT11	37.38	30.00	45.63	CF	F	SCD 16

*OPTIONAL WALL MOUNTING KIT REQUIRED.
REFER TO PAGE 273 FOR DETAILS.

600, 480 Delta Primary Volts

480Y/277 Secondary Volts

60 Hz

kVA	Catalog Number	Case Style (Pages 260 - 267)	Approx. Dimensions (Inches)			Approx. Weight (Lbs.)	Mtg Type W - Wall F - Floor	Wiring Diagram (Pages 276 - 288)
			Width	Depth	Height			
2	P002QKKB	NQT3	12.38	5.44	12.39	65	W	SCD 20
3	P003QKKB	NQT3	12.38	5.44	12.39	69	W	SCD 20
6	P006QKKF	NQT4	15.19	6.94	16.39	190	W	SCD 20
9	P009QKKF	NQT5	16.63	10.25	17.89	270	W	SCD 47
15	P015QKKF	NQT7	20.25	13.00	23.38	380	F or W*	SCD 47
30	P030QKKF	NQT7	20.25	13.00	23.38	472	F or W*	SCD 11
45	P045QKKF	NQT8	22.25	13.00	28.38	680	F or W*	SCD 11
75	P075QKKF	NQT9	31.25	16.00	29.88	1650	F	SCD 11
112.5	P112QKKF	NQT10	38.44	26.00	39.13	CF	F	Consult Factory
150	P150QKKF	NQT11	37.38	30.00	45.63	CF	F	Consult Factory

*OPTIONAL WALL MOUNTING KIT REQUIRED.
REFER TO PAGE 273 FOR DETAILS.



SECTION 9

HPS POWERPLUS™ MINI POWER CENTERS

Aluminum, Single Phase Mini Power Centers

Applications & Features	242
Features and Benefits	243
Single Phase Selection Tables	244
Enclosure Dimensional Drawings	268
Wiring Schematic Drawings	289

HPS PowerPlus™ Mini Power Center



The Compact Economical Solution

The HPS PowerPlus™ is a convenient pre-wired power center that saves you time, money, and space. HPS PowerPlus combines a pre-wired primary breaker, secondary power panel, and dry-type shielded transformer in a Type 3R enclosure.

It is ideal for applications such as in industrial locations, temporary power at construction sites, commercial buildings, test equipment, and plant assembly lines.



SECTION 9



Features and Benefits

- Type 3R indoor/outdoor enclosure (optional 316 Stainless Steel enclosure available)
- 480 Primary, 120/240 Secondary
- Single Phase
- 60 Hz Frequency
- 5, 7.5, 10, 15, 25 kVA available
- Shielded transformer
- 180° insulation class
- 115° temperature rise
- Primary taps: 2 - 5% FCBN
- Meet NEMA, ANSI, & OSHA standards
- 15 year limited warranty on transformer
- 1 year limited warranty on Mini Power Center

Transformer: HPS shielded transformers are encapsulated for general purpose indoor or outdoor use within a variety of environments. An electrostatic shield is placed between the primary and secondary winding and grounded to reduce electrical interference and to provide additional protection.

Panel Assembly: The HPS PowerPlus assembly comes fully equipped with a primary main circuit breaker. It will hold up to 20 1-pole or 10 2-pole, one inch, common trip, duplex secondary branch circuit breakers and ground fault circuit breakers. Once you have established your branch circuit requirements, contact your local distributor to obtain your branch circuit breakers.

Connections: HPS PowerPlus accepts Aluminum or Copper conductors.

Protection: The transformer is protected by the primary main breaker, which handles high interrupting fault conditions. The N.E.C. requires a secondary breaker to be between the transformer and the panel.

Approvals:

HPS PowerPlus™:  c UL US LISTED



ALUMINUM WOUND, SINGLE PHASE NEMA 3R STYLE ENCLOSURE



480 Primary Volts

120/240 Secondary Volts

60 Hz

kVA	Catalog Number	Case Style (Pages 268 - 270)	Max. Secondary Circuits*		Approx. Dimensions (Inches)			Approx. Weight (Lbs.)	Mtg Type W - Wall F - Floor	Wiring Diagram (Pages 289 - 290)
			120 V (1 Pole)	240 V (2 Pole)	Width	Depth	Height			
5	M1PC005LESF	PPE1	8	4	11.250	7.750	31.938	127	W	SCD 49
7.5	M1PC007LESF	PPE2	8	4	13.875	11.125	31.938	201	W	SCD 49
10	M1PC010LESF	PPE3	8	4	13.875	11.125	34.188	210	W	SCD 49
15	M1PC015LESF	PPE4	12	6	15.125	12.500	34.188	291	W	SCD 50
25	M1PC025LESF	PPE5	20	10	16.250	13.625	41.563	423	W	SCD 51

*Please contact factory for exact number of secondary circuits available

**Contact factory for copper information

ALUMINUM WOUND, SINGLE PHASE 316 STAINLESS STEEL ENCLOSURE

480 Primary Volts

120/240 Secondary Volts

60 Hz

kVA	Catalog Number	Case Style (Pages 268 - 270)	Max. Secondary Circuits*		Approx. Dimensions (Inches)			Approx. Weight (Lbs.)	Mtg Type W - Wall F - Floor	Wiring Diagram (Pages 289 - 290)
			120 V (1 Pole)	240 V (2 Pole)	Width	Depth	Height			
5	M1PC005LESF7	PPE1	8	4	11.250	7.750	31.938	127	W	SCD 49
7.5	M1PC007LESF7	PPE2	8	4	13.875	11.125	31.938	201	W	SCD 49
10	M1PC010LESF7	PPE3	8	4	13.875	11.125	34.188	210	W	SCD 49
15	M1PC015LESF7	PPE4	12	6	15.125	12.500	34.188	291	W	SCD 50
25	M1PC025LESF7	PPE5	20	10	16.250	13.625	41.563	423	W	SCD 51

*Please contact factory for exact number of secondary circuits available

**Contact factory for copper information

SECTION 9





SECTION 10

AUTOTRANSFORMERS

600 Volt Class, Three Phase

Description and Applications	246
Three Phase Standard Specifications	247
Three Phase Selection Tables	248
Enclosure Dimensional Drawings	260
Accessories - Enclosure Mounting Kits, Anti-Vibration Pads & Isolators	271

GENERAL PURPOSE AUTOTRANSFORMERS

HPS three phase autotransformers are available for applications where small voltage corrections are necessary in a distribution system. They are frequently used as an economical alternative to general purpose distribution isolation transformers to adjust the supply voltage to match specific load requirements when load isolation from the supply line is not required. Autotransformers can be used as either a step-up or step-down transformer.

THREE PHASE STANDARD SPECIFICATIONS

3 TO (15)(30)(45) KVA



(30)(45)(75) TO 500 KVA



	3 kVA to (15)(30)(45) kVA	(30)(45)(75) to 500 kVA
UL Listed	File: E258346 (UL1604, Class I, Division 2)	File: E112313
CSA Certified	File: LR3902	File: LR3902
ABS Type Approval	Certificate No.: 04-HS435190/1-PDA	Optional
Frequency	60 Hz	60 Hz
Insulation System	130°C (80°C rise) standard on all units	180°C (115°C rise) or 200°C (130°C rise) or 220°C (150°C rise) available.
Encapsulation	Select units are encapsulated with electrical grade silica sand and resin compounds.	Not Applicable (ventilated core and coil)
Enclosure Type	Heavy Duty NEMA Type 3R Optional NEMA 4, 4X (Stainless steel) and 12.	Heavy Duty NEMA Type 3R Optional NEMA 4, 4X (Stainless steel) and 12.
Termination	Top accessible separate high and low voltage lead wires or copper tabs.	Front accessible compartment with high and low voltage terminals; connectors suitable for copper provided where indicated.
Conduit Knock-Outs	Standard side and rear knock-outs on all units.	Standard side knock-outs on all units.
Impedance	Less than 3%.	Less than 3%.
Mounting	Refer to tables on the next page.	Refer to tables on next page.
Sound Level	Meets NEMA ST-20 standards. (Optional low noise available on request)	Meets NEMA ST-20 standards. (Optional low noise available on request)

Other voltages not listed in this section are available upon request. Please contact customer service for details, price and availability.

Note: Autotransformers incorporate a single winding design without isolation in a Wye configuration.



SECTION 10

THREE PHASE, NEMA 3R STYLE ENCLOSURE



600Y, 480Y Volts
480Y, 380Y Volts (Alternate Rating)

60 Hz
50/60 Hz

kVA	Catalog Number	Case Style (Pages 260 - 267)	Approx. Dimensions (Inches)			Approx. Weight (Lbs.)	Mtg Type W - Wall F - Floor	Wiring Diagram (Pages 276 - 288)
			Width	Depth	Height			
3	Y003PKCB	NQT2	9.38	4.94	8.63	19	W	SCD 24
6	Y006PKCB	NQT2	9.38	4.94	8.63	26	W	SCD 24
9	Y009PKCB	NQT3	12.38	5.44	11.13	50	W	SCD 24
15	Y015PKCB	NQT3	12.38	5.44	11.13	60	W	SCD 24
30	Y030PKCF	NQT4	15.19	6.94	16.39	135	W	SCD 24
45	Y045PKCN	NH5	19.40	20.20	21.50	130	F or W*	SCD 24
75	Y075PKCN	NH5	19.40	20.20	21.50	170	F or W*	SCD 24
112.5	Y112PKC	NH6	23.90	25.00	28.75	245	F or W*	SCD 24
150	Y150PKC	NH6	23.90	25.00	28.75	285	F or W*	SCD 24
225	Y225PKC	NH6	23.90	25.00	28.75	360	F or W*	SCD 24
300	Y300PKC	NH3	26.00	21.00	38.00	500	F or W*	SCD 24
500	Y500PKC	NH3	26.00	21.00	38.00	650	F or W*	SCD 24

Above units from 3 kVA to 30 kVA are encapsulated.
OPTIONAL NEUTRAL AVAILABLE UPON REQUEST.

*WALL MOUNTING KIT AND/OR DRIP PLATE KIT REQUIRED.
REFER TO PAGES 271 TO 273 FOR DETAILS.

600Y, 480Y, 400Y, 240Y 208Y Volts

60 Hz

kVA	Catalog Number	Case Style (Pages 260 - 267)	Approx. Dimensions (Inches)			Approx. Weight (Lbs.)	Mtg Type W - Wall F - Floor	Wiring Diagram (Pages 276 - 288)
			Width	Depth	Height			
3	Y003QTCB	NQT3	12.38	5.44	11.13	49	W	SCD 14
6	Y006QTCB	NQT3	12.38	5.44	11.13	69	W	SCD 14
9	Y009QTCF	NQT4	15.19	6.94	16.39	138	W	SCD 14
15	Y015QTCF	NQT4	15.19	6.94	16.39	170	W	SCD 14
30	Y030QTCN	NH5	19.40	20.20	21.50	210	F or W*	SCD 14
45	Y045QTC	NH6	23.90	25.00	28.75	305	F or W*	SCD 14
75	Y075QTC	NH6	23.90	25.00	28.75	400	F or W*	SCD 14
112.5	Y112QTC	NH3	26.00	21.00	38.00	585	F or W*	SCD 14
150	Y150QTC	NH3	26.00	21.00	38.00	685	F or W*	SCD 14
225	Y225QTC	NH4	32.00	29.50	41.00	980	F	SCD 14

Above units from 3 kVA to 15 kVA are encapsulated.
OPTIONAL NEUTRAL AVAILABLE UPON REQUEST.

*WALL MOUNTING KIT AND/OR DRIP PLATE KIT REQUIRED.
REFER TO PAGES 271 TO 273 FOR DETAILS.

240Y, 216Y, 208Y

60 Hz

kVA	Catalog Number	Case Style (Pages 260 - 267)	Approx. Dimensions (Inches)			Approx. Weight (Lbs.)	Mtg Type W - Wall F - Floor	Wiring Diagram (Pages 276 - 288)
			Width	Depth	Height			
3	Y003CECB	NQT2	9.38	4.94	8.63	19	W	SCD 15
6	Y006CECB	NQT2	9.38	4.94	8.63	25	W	SCD 15
9	Y009CECB	NQT3	12.38	5.44	11.13	49	W	SCD 15
15	Y015CECB	NQT3	12.38	5.44	11.13	58	W	SCD 15
30	Y030CECF	NQT4	15.19	6.94	16.39	115	W	SCD 15
45	Y045CECF	NQT5	16.63	10.25	17.89	130	F or W*	SCD 15
75	Y075CECN	NH5	19.40	20.20	21.50	170	F or W*	SCD 15

Above units from 3 kVA to 45 kVA are encapsulated.
OPTIONAL NEUTRAL AVAILABLE UPON REQUEST.

*WALL MOUNTING KIT AND/OR DRIP PLATE KIT REQUIRED.
REFER TO PAGES 271 TO 273 FOR DETAILS.

Products listed on this page are available as 'CE Mark' products. Please consult our sales office.







SECTION 11

HPS MILLENNIUM™ GENERAL PURPOSE MEDIUM VOLTAGE DISTRIBUTION TRANSFORMERS

1.2 KV to 5KV Class Dry Type Single Phase and Three Phase

Medium Voltage Energy Efficient Guidelines	250
Energy Efficient Guidelines for U.S.	250
Energy Efficient Guidelines for Canada	251
Aluminum and Copper Standard Specifications.....	252
Single Phase Aluminum Selection Tables	253
Single Phase Copper Selection Tables	254
Three Phase Aluminum Selection Tables	255
Three Phase Copper Selection Tables	257
Enclosure Dimensional Drawings	260
Accessories - Enclosure Mounting Kits, Anti-Vibration Pads & Isolators	271
Termination Details	275

MEDIUM VOLTAGE DISTRIBUTION TRANSFORMER ENERGY EFFICIENCY GUIDELINES

In the past several years, there has been an accelerated rate of change to introduce energy efficiency standards for transformers in North America. In addition to the benefits to the environment, energy efficient transformers realize substantial savings in operating costs, thereby having a direct impact on the initial investment evaluated over a period of time.

United States - Energy Efficiency Regulations

In the U.S. all medium voltage dry-type distribution transformers (as defined below) manufactured after January 1st, 2010, must meet the minimum energy efficiency standards outlined in DOE 10 CFR Part 431. The range of product covered by these standards are:

Primary (high) Voltage		601V to 34.5 kV
Secondary (low) Voltage		600V and below
Dry-Type Rating	Single Phase	15-833 kVA
	Three Phase	15-2500 kVA
Frequency		60 Hz only

For transformers exempted from the DOE efficiency regulations please refer to the following DOE link:
http://www.access.gpo.gov/nara/cfr/waisidx_09/10cfr431_09.html

US Department of Energy DOE 10 CFR Part 431 Efficiency Levels Dry-Type Distribution Transformers - <u>Medium Voltage</u>							
Single Phase				Three Phase			
kVA	20 - 45 kV BIL Efficiency (%)	46 - 95 kV BIL Efficiency (%)	≥ 96 kV BIL Efficiency (%)	kVA	20 - 45 kV BIL Efficiency (%)	46 - 95 kV BIL Efficiency (%)	≥ 96 kV BIL Efficiency (%)
15	98.10	97.86	-	15	97.50	97.18	-
25	98.33	98.12	-	30	97.90	97.63	-
37.5	98.49	98.30	-	45	98.10	97.86	-
50	98.60	98.42	-	75	98.33	98.12	-
75	98.73	98.57	98.53	112.5	98.49	98.30	-
100	98.82	98.67	98.63	150	98.60	98.42	-
167	98.96	98.83	98.80	225	98.73	98.57	98.53
250	99.07	98.95	98.91	300	98.82	98.67	98.63
333	99.14	99.03	98.99	500	98.96	98.83	98.80
500	99.22	99.12	99.09	750	99.07	98.95	98.91
667	99.27	99.18	99.15	1000	99.14	99.03	98.99
833	99.31	99.23	99.20	1500	99.22	99.12	99.09
				2000	99.27	99.18	99.15
				2500	99.31	99.23	99.20

All efficiency values are at 50% of nameplate-rated load.



MEDIUM VOLTAGE DISTRIBUTION TRANSFORMER ENERGY EFFICIENCY GUIDELINES

Canada - Energy Efficiency Regulations

In Canada, all medium voltage dry-type distribution transformers (as defined below) manufactured after January 1st, 2005, must meet the minimum energy efficiency guidelines as per CSA C802.2. NRCAN has recently evaluated the U.S. DOE 10 CFR Part 431 efficiency levels and determined they are more cost effective and thus, suitable for use in Canada. As a result, in 2010 the Canadian Energy Efficiency Act - Energy Efficiency Regulations (SOR/94-651) will be updated and the regulation will harmonize the minimum efficiency levels with those established in the U.S. DOE 10 CFR Part 431. At the time of printing of this catalog, these harmonized efficiency levels were proposed only; but HPS believes these efficiency standards will be added to the Canadian Efficiency Regulations in the near future.

The range of product covered by these standards are:

Primary Voltage BIL Rating		> 1.2 kV class (\geq 20 kV BIL)
Secondary (low) Voltage Line Current		Less than 4000 Amps
Dry-Type Rating	Single Phase	15-833 kVA
	Three Phase	15-7500 kVA
Frequency		60 Hz only

For transformers exempted from the Canadian Efficiency Regulations please refer to the following NRCAN link:
<http://laws.justice.gc.ca/eng/sor-94-651/page-1.html>

Canadian Energy Efficiency Act - Energy Efficiency Regulations Efficiency Levels*							
Dry-Type Distribution Transformers - Medium Voltage							
Single Phase				Three Phase			
kVA	20 - 45 kV BIL Efficiency (%)	46 - 95 kV BIL Efficiency (%)	\geq 96 kV BIL Efficiency (%)	kVA	20 - 45 kV BIL Efficiency (%)	46 - 95 kV BIL Efficiency (%)	\geq 96 kV BIL Efficiency (%)
15	98.10	97.86	97.80	15	97.50	97.18	97.11
25	98.33	98.12	98.07	30	97.90	97.63	97.57
37.5	98.49	98.30	98.25	45	98.10	97.86	97.80
50	98.60	98.42	98.37	75	98.33	98.12	98.07
75	98.73	98.57	98.53	112.5	98.49	98.30	98.25
100	98.82	98.67	98.63	150	98.60	98.42	98.37
167	98.96	98.83	98.80	225	98.73	98.57	98.53
250	99.07	98.95	98.91	300	98.82	98.67	98.63
333	99.14	99.03	98.99	500	98.96	98.83	98.80
500	99.22	99.12	99.09	750	99.07	98.95	98.91
667	99.27	99.18	99.15	1000	99.14	99.03	98.99
833	99.31	99.23	99.20	1500	99.22	99.12	99.09
				2000	99.27	99.18	99.15
				2500	99.31	99.23	99.20
				3000	99.34	99.26	99.24
				3750	99.38	99.30	99.28
				5000	99.42	99.35	99.33
				7500	99.48	99.41	99.39

All efficiency values are at 50% of nameplate-rated load.



1.2KV to 5KV CLASS DISTRIBUTION TRANSFORMERS

HPS Millennium™ energy efficient medium voltage distribution transformers are designed for stepping down incoming higher voltage power to utilize voltages for commercial, institutional or industrial applications. The standard NEMA 3R ventilated construction is suitable for indoor or outdoor applications.

ALUMINUM & COPPER WOUND STANDARD SPECIFICATIONS



SINGLE PHASE



THREE PHASE

	15 to 333 kVA	15 to 1500 kVA
Efficiency (where applicable)	Meets U.S. DOE CFR Part 431 and the Canadian Efficiency Regulations efficiency levels at 50% of rated load. Efficiencies are calculated under a linear load profile.	
UL Listed	File: E147879	File: E147879
CSA Certified	File: LR3902	File: LR3902
Frequency	60 Hz	60 Hz
Insulation System	220°C (150°C rise) 200°C (130°C rise) on some copper units (Optional 115°C and 80°C rise available)	220°C (150°C rise) 200°C (130°C rise) on some copper units (Optional 115°C and 80°C rise available)
Enclosure Type	Heavy Duty Ventilated NEMA Type 3R (Optional NEMA 4, 4X and 12 available)	Heavy Duty Ventilated NEMA Type 3R (Optional NEMA 4, 4X and 12 available)
Enclosure Finish	ANSI 61 Grey, UL50	ANSI 61 Grey, UL50
Standard Primary Taps	Refer to wiring diagrams for details.	Refer to wiring diagrams for details.
Termination	Front accessible separate high and low voltage terminals; connectors suitable for aluminum and copper are provided for easy cable installation.	Front accessible separate high and low voltage terminals; connectors suitable for aluminum and copper are provided for easy cable installation.
Conduit Knock-Outs	Standard on most units up to 100 kVA.	Standard on units up to 150 kVA
Impedance	Typically 2 to 5%	Typically 3 to 6%
Mounting	Floor or wall/ceiling mounting available. Refer to selection tables for details.	Floor or wall/ceiling mounting available. Refer to selection tables for details.
Seismic	Seismically certified in accordance with 2009 IBC for $S_{Ds} \leq 2.00g$, $z/h = 1.0$ and $I_p = 1.5$	Seismically certified in accordance with 2009 IBC for $S_{Ds} \leq 2.00g$, $z/h = 1.0$ and $I_p = 1.5$

Other voltages not listed in this section are available upon request for both aluminum and copper wound units. Please contact customer service for details, price and availability.

SECTION 11



ALUMINUM WOUND, SINGLE PHASE, NEMA 3R STYLE ENCLOSURE



2400 Primary Volts

120/240 Secondary Volts

60 Hz

kVA	Catalog Number	Case Style (Pages 260 - 267)	Approx. Dimensions (Inches)			Approx. Weight (Lbs.)	Mtg Type W - Wall F - Floor	Wiring Diagram (Pages 276 - 288)
			Width	Depth	Height			
15	MV1S015RE	NH6	23.90	25.00	28.75	290	F or W *	SCD 6
25	MV1S025RE	NH6	23.90	25.00	28.75	350	F or W *	SCD 6
37.5	MV1S037RE	NH6	23.90	25.00	28.75	420	F or W *	SCD 6
50	MV1S050RE	NH3	26.00	25.00	38.00	570	F or W *	SCD 6
75	MV1S075RE	NH3	26.00	25.00	38.00	660	F or W *	SCD 6
100	MV1S100RE	NH4	32.00	29.50	41.00	810	F	SCD 6
150	MV1S150RE	NJ4	32.00	32.50	50.00	1280	F	SCD 6
167	MV1S167RE	NJ4	32.00	32.50	50.00	1320	F	SCD 6
250	MV1S250RE	NJ4	32.00	32.50	50.00	1560	F	SCD 6
333	MV1S333RE	NJ2	48.50	38.40	59.00	1980	F	SCD 6

For shielded units, please add the suffix "S" to the above part numbers.

**WALL MOUNTING KIT AND/OR DRIP PLATE KIT REQUIRED.
REFER TO PAGES 271 TO 273 FOR DETAILS.*

4160 Primary Volts

120/240 Secondary Volts

60 Hz

kVA	Catalog Number	Case Style (Pages 260 - 267)	Approx. Dimensions (Inches)			Approx. Weight (Lbs.)	Mtg Type W - Wall F - Floor	Wiring Diagram (Pages 276 - 288)
			Width	Depth	Height			
15	MV1S015SE	NH6	23.90	25.00	28.75	290	F or W *	SCD 6
25	MV1S025SE	NH6	23.90	25.00	28.75	350	F or W *	SCD 6
37.5	MV1S037SE	NH6	23.90	25.00	28.75	420	F or W *	SCD 6
50	MV1S050SE	NH3	26.00	25.00	38.00	570	F or W *	SCD 6
75	MV1S075SE	NH3	26.00	25.00	38.00	660	F or W *	SCD 6
100	MV1S100SE	NH4	32.00	29.50	41.00	810	F	SCD 6
150	MV1S150SE	NJ4	32.00	32.50	50.00	1280	F	SCD 6
167	MV1S167SE	NJ4	32.00	32.50	50.00	1320	F	SCD 6
250	MV1S250SE	NJ4	32.00	32.50	50.00	1560	F	SCD 6
333	MV1S333SE	NJ2	48.50	38.40	59.00	1980	F	SCD 6

For shielded units, please add the suffix "S" to the above part numbers.

**WALL MOUNTING KIT AND/OR DRIP PLATE KIT REQUIRED.
REFER TO PAGES 271 TO 273 FOR DETAILS.*



COPPER WOUND, SINGLE PHASE, NEMA 3R STYLE ENCLOSURE



2400 Primary Volts

120/240 Secondary Volts

60 Hz

kVA	Catalog Number	Case Style (Pages 260 - 267)	Approx. Dimensions (Inches)			Approx. Weight (Lbs)	Mtg Type W - Wall F - Floor	Wiring Diagram (Pages 276 - 288)
			Width	Depth	Height			
15	MV1S015RECN	NH6	23.90	25.00	28.75	320	F or W *	SCD 6
25	MV1S025RECN	NH6	23.90	25.00	28.75	390	F or W *	SCD 6
37.5	MV1S037RECN	NH6	23.90	25.00	28.75	480	F or W *	SCD 6
50	MV1S050RECN	NH3	26.00	25.00	38.00	660	F or W *	SCD 6
75	MV1S075REC	NH3	26.00	25.00	38.00	770	F	SCD 6
100	MV1S100REC	NH4	32.00	29.50	41.00	970	F	SCD 6
150	MV1S150REC	NJ4	32.00	32.50	50.00	1300	F	SCD 6
167	MV1S167REC	NJ4	32.00	32.50	50.00	1440	F	SCD 6
250	MV1S250REC	NJ4	32.00	32.50	50.00	1800	F	SCD 6
333	MV1S333REC	NJ2	48.50	38.40	59.00	2280	F	SCD 6

For shielded units, please replace the letter "C" with a "K" in the above part numbers.

*WALL MOUNTING KIT AND/OR DRIP PLATE KIT REQUIRED.
REFER TO PAGES 271 TO 273 FOR DETAILS.

4160 Primary Volts

120/240 Secondary Volts

60 Hz

kVA	Catalog Number	Case Style (Pages 260 - 267)	Approx. Dimensions (Inches)			Approx. Weight (Lbs)	Mtg Type W - Wall F - Floor	Wiring Diagram (Pages 276 - 288)
			Width	Depth	Height			
15	MV1S015SECN	NH6	23.90	25.00	28.75	320	F or W *	SCD 6
25	MV1S025SECN	NH6	23.90	25.00	28.75	390	F or W *	SCD 6
37.5	MV1S037SECN	NH6	23.90	25.00	28.75	480	F or W *	SCD 6
50	MV1S050SECN	NH3	26.00	25.00	38.00	660	F or W *	SCD 6
75	MV1S075SECN	NH3	26.00	25.00	38.00	770	F	SCD 6
100	MV1S100SEC	NH4	32.00	29.50	41.00	970	F	SCD 6
150	MV1S150SEC	NJ4	32.00	32.50	50.00	1300	F	SCD 6
167	MV1S167SEC	NJ4	32.00	32.50	50.00	1440	F	SCD 6
250	MV1S250SEC	NJ4	32.00	32.50	50.00	1800	F	SCD 6
333	MV1S333SEC	NJ2	48.50	38.40	59.00	2280	F	SCD 6

For shielded units, please replace the letter "C" with a "K" in the above part numbers.

*WALL MOUNTING KIT AND/OR DRIP PLATE KIT REQUIRED.
REFER TO PAGES 271 TO 273 FOR DETAILS.

SECTION 11



FOR TERMINATION DETAILS SEE PAGE 275

FOR ACCESSORIES SEE PAGES 271 TO 274



ALUMINUM WOUND, THREE PHASE, NEMA 3R STYLE ENCLOSURE



2400 Delta Primary Volts

208Y/120 Secondary Volts

60 Hz

kVA	Catalog Number	Case Style (Pages 260 - 267)	Approx. Dimensions (Inches)			Approx. Weight (Lbs)	Mtg Type W - Wall F - Floor	Wiring Diagram (Pages 276 - 288)
			Width	Depth	Height			
15	MV3S015RB	NH6	23.90	25.00	28.75	350	F or W *	SCD 8
30	MV3S030RB	NH6	23.90	25.00	28.75	425	F or W *	SCD 10
45	MV3S045RB	NH3	26.00	25.00	38.00	600	F or W *	SCD 10
75	MV3S075RB	NH4	32.00	29.50	41.00	800	F	SCD 10
112.5	MV3S112RB	NH4	32.00	29.50	41.00	1200	F	SCD 10
150	MV3S150RB	NJ1	39.50	34.00	51.50	1400	F	SCD 10
225	MV3S225RB	NJ1	39.50	34.00	51.50	1600	F	SCD 10
300	MV3S300RB	NJ1	39.50	34.00	51.50	1800	F	SCD 10
500	MV3S500RB	NJ2	48.50	38.40	59.00	2600	F	SCD 10
750	MV3S750RB	NJ6	64.00	44.40	71.00	4200	F	SCD 10
1000	MV3S1000RB	NJ6	64.00	44.40	71.00	4500	F	SCD 10
1250	MV3S1250RB	NJ6	64.00	44.40	71.00	5300	F	SCD 10
1500	MV3S1500RB	NJ7	64.00	51.40	75.00	6300	F	SCD 10

For shielded units, please add the suffix "S" to the above part numbers.

*WALL MOUNTING KIT AND/OR DRIP PLATE KIT REQUIRED.
REFER TO PAGES 271 TO 273 FOR DETAILS.

2400 Delta Primary Volts

480Y/277 Secondary Volts

60 Hz

kVA	Catalog Number	Case Style (Pages 260 - 267)	Approx. Dimensions (Inches)			Approx. Weight (Lbs)	Mtg Type W - Wall F - Floor	Wiring Diagram (Pages 276 - 288)
			Width	Depth	Height			
15	MV3S015RK	NH6	23.90	25.00	28.75	350	F or W *	SCD 8
30	MV3S030RK	NH6	23.90	25.00	28.75	425	F or W *	SCD 10
45	MV3S045RK	NH3	26.00	25.00	38.00	600	F or W *	SCD 10
75	MV3S075RK	NH4	32.00	29.50	41.00	800	F	SCD 10
112.5	MV3S112RK	NH4	32.00	29.50	41.00	1200	F	SCD 10
150	MV3S150RK	NJ1	39.50	34.00	51.50	1400	F	SCD 10
225	MV3S225RK	NJ1	39.50	34.00	51.50	1600	F	SCD 10
300	MV3S300RK	NJ1	39.50	34.00	51.50	1800	F	SCD 10
500	MV3S500RK	NJ2	48.50	38.40	59.00	2600	F	SCD 10
750	MV3S750RK	NJ6	64.00	44.40	71.00	4200	F	SCD 10
1000	MV3S1000RK	NJ6	64.00	44.40	71.00	4500	F	SCD 10
1250	MV3S1250RK	NJ6	64.00	44.40	71.00	5300	F	SCD 10
1500	MV3S1500RK	NJ7	64.00	51.40	75.00	6300	F	SCD 10

For shielded units, please add the suffix "S" to the above part numbers.

*WALL MOUNTING KIT AND/OR DRIP PLATE KIT REQUIRED.
REFER TO PAGES 271 TO 273 FOR DETAILS.

2400 Delta Primary Volts

600Y/347 Secondary Volts

60 Hz

kVA	Catalog Number	Case Style (Pages 260 - 267)	Approx. Dimensions (Inches)			Approx. Weight (Lbs)	Mtg Type W - Wall F - Floor	Wiring Diagram (Pages 276 - 288)
			Width	Depth	Height			
15	MV3S015RP	NH6	23.90	25.00	28.75	350	F or W *	SCD 8
30	MV3S030RP	NH6	23.90	25.00	28.75	425	F or W *	SCD 10
45	MV3S045RP	NH3	26.00	25.00	38.00	600	F or W *	SCD 10
75	MV3S075RP	NH4	32.00	29.50	41.00	800	F	SCD 10
112.5	MV3S112RP	NH4	32.00	29.50	41.00	1200	F	SCD 10
150	MV3S150RP	NJ1	39.50	34.00	51.50	1400	F	SCD 10
225	MV3S225RP	NJ1	39.50	34.00	51.50	1600	F	SCD 10
300	MV3S300RP	NJ1	39.50	34.00	51.50	1800	F	SCD 10
500	MV3S500RP	NJ2	48.50	38.40	59.00	2600	F	SCD 10
750	MV3S750RP	NJ6	64.00	44.40	71.00	4200	F	SCD 10
1000	MV3S1000RP	NJ6	64.00	44.40	71.00	4600	F	SCD 10
1250	MV3S1250RP	NJ6	64.00	44.40	71.00	5200	F	SCD 10
1500	MV3S1500RP	NJ7	64.00	51.40	75.00	6300	F	SCD 10

For shielded units, please add the suffix "S" to the above part numbers.

*WALL MOUNTING KIT AND/OR DRIP PLATE KIT REQUIRED.
REFER TO PAGES 271 TO 273 FOR DETAILS.

FOR TERMINATION DETAILS SEE PAGE 275

FOR ACCESSORIES SEE PAGES 271 TO 274



ALUMINUM WOUND, THREE PHASE, NEMA 3R STYLE ENCLOSURE



4160 Delta Primary Volts

208Y/120 Secondary Volts

60 Hz

kVA	Catalog Number	Case Style (Pages 260 - 267)	Approx. Dimensions (Inches)			Approx. Weight (Lbs)	Mtg Type W - Wall F - Floor	Wiring Diagram (Pages 276 - 288)
			Width	Depth	Height			
15	MV3S015SB	NH6	23.90	25.00	28.75	350	F or W *	SCD 8
30	MV3S030SB	NH6	23.90	25.00	28.75	425	F or W *	SCD 10
45	MV3S045SB	NH3	26.00	25.00	38.00	600	F or W *	SCD 10
75	MV3S075SB	NH4	32.00	29.50	41.00	800	F	SCD 10
112.5	MV3S112SB	NH4	32.00	29.50	41.00	1200	F	SCD 10
150	MV3S150SB	NJ1	39.50	34.00	51.50	1400	F	SCD 10
225	MV3S225SB	NJ1	39.50	34.00	51.50	1600	F	SCD 10
300	MV3S300SB	NJ1	39.50	34.00	51.50	1800	F	SCD 10
500	MV3S500SB	NJ2	48.50	38.40	59.00	2600	F	SCD 10
750	MV3S750SB	NJ6	64.00	44.40	71.00	4200	F	SCD 10
1000	MV3S1000SB	NJ6	64.00	44.40	71.00	4600	F	SCD 10
1250	MV3S1250SB	NJ6	64.00	44.40	71.00	5300	F	SCD 10
1500	MV3S1500SB	NJ7	64.00	51.40	75.00	6300	F	SCD 10

For shielded units, please add the suffix "S" to the above part numbers.

*WALL MOUNTING KIT AND/OR DRIP PLATE KIT REQUIRED.
REFER TO PAGES 271 TO 273 FOR DETAILS.

4160 Delta Primary Volts

480Y/277 Secondary Volts

60 Hz

kVA	Catalog Number	Case Style (Pages 260 - 267)	Approx. Dimensions (Inches)			Approx. Weight (Lbs)	Mtg Type W - Wall F - Floor	Wiring Diagram (Pages 276 - 288)
			Width	Depth	Height			
15	MV3S015SK	NH6	23.90	25.00	28.75	350	F or W *	SCD 8
30	MV3S030SK	NH6	23.90	25.00	28.75	425	F or W *	SCD 10
45	MV3S045SK	NH3	26.00	25.00	38.00	600	F or W *	SCD 10
75	MV3S075SK	NH4	32.00	29.50	41.00	800	F	SCD 10
112.5	MV3S112SK	NH4	32.00	29.50	41.00	1200	F	SCD 10
150	MV3S150SK	NJ1	39.50	34.00	51.50	1400	F	SCD 10
225	MV3S225SK	NJ1	39.50	34.00	51.50	1600	F	SCD 10
300	MV3S300SK	NJ1	39.50	34.00	51.50	1800	F	SCD 10
500	MV3S500SK	NJ2	48.50	38.40	59.00	2600	F	SCD 10
750	MV3S750SK	NJ6	64.00	44.40	71.00	4200	F	SCD 10
1000	MV3S1000SK	NJ6	64.00	44.40	71.00	4500	F	SCD 10
1250	MV3S1250SK	NJ6	64.00	44.40	71.00	5300	F	SCD 10
1500	MV3S1500SK	NJ7	64.00	51.40	75.00	6300	F	SCD 10

For shielded units, please add the suffix "S" to the above part numbers.

*WALL MOUNTING KIT AND/OR DRIP PLATE KIT REQUIRED.
REFER TO PAGES 271 TO 273 FOR DETAILS.

4160 Delta Primary Volts

600Y/347 Secondary Volts

60 Hz

kVA	Catalog Number	Case Style (Pages 260 - 267)	Approx. Dimensions (Inches)			Approx. Weight (Lbs)	Mtg Type W - Wall F - Floor	Wiring Diagram (Pages 276 - 288)
			Width	Depth	Height			
15	MV3S015SP	NH6	23.90	25.00	28.75	350	F or W *	SCD 8
30	MV3S030SP	NH6	23.90	25.00	28.75	425	F or W *	SCD 10
45	MV3S045SP	NH3	26.00	25.00	38.00	600	F or W *	SCD 10
75	MV3S075SP	NH4	32.00	29.50	41.00	800	F	SCD 10
112.5	MV3S112SP	NH4	32.00	29.50	41.00	1200	F	SCD 10
150	MV3S150SP	NJ1	39.50	34.00	51.50	1400	F	SCD 10
225	MV3S225SP	NJ1	39.50	34.00	51.50	1600	F	SCD 10
300	MV3S300SP	NJ1	39.50	34.00	51.50	1800	F	SCD 10
500	MV3S500SP	NJ2	48.50	38.40	59.00	2600	F	SCD 10
750	MV3S750SP	NJ6	64.00	44.40	71.00	4200	F	SCD 10
1000	MV3S1000SP	NJ6	64.00	44.40	71.00	4600	F	SCD 10
1250	MV3S1250SP	NJ6	64.00	44.40	71.00	5200	F	SCD 10
1500	MV3S1500SP	NJ7	64.00	51.40	75.00	6300	F	SCD 10

For shielded units, please add the suffix "S" to the above part numbers.

*WALL MOUNTING KIT AND/OR DRIP PLATE KIT REQUIRED.
REFER TO PAGES 271 TO 273 FOR DETAILS.

FOR TERMINATION DETAILS SEE PAGE 275

FOR ACCESSORIES SEE PAGES 271 TO 274



SECTION 11

SECTION 11

ENERGY EFFICIENT MEDIUM VOLTAGE DISTRIBUTION

COPPER WOUND, THREE PHASE, NEMA 3R STYLE ENCLOSURE



2400 Delta Primary Volts

208Y/120 Secondary Volts

60 Hz

kVA	Catalog Number	Case Style (Pages 260 - 267)	Approx. Dimensions (Inches)			Approx. Weight (Lbs)	Mtg Type W - Wall F - Floor	Wiring Diagram (Pages 276 - 288)
			Width	Depth	Height			
15	MV3S015RBCN	NH6	23.90	25.00	28.75	400	F or W *	SCD 8
30	MV3S030RBCN	NH6	23.90	25.00	28.75	500	F or W *	SCD 10
45	MV3S045RBCN	NH3	26.00	25.00	38.00	600	F or W *	SCD 10
75	MV3S075RBCN	NH4	32.00	29.50	41.00	900	F	SCD 10
112.5	MV3S112RBCN	NH4	32.00	29.50	41.00	1100	F	SCD 10
150	MV3S150RBCN	NJ1	39.50	34.00	51.50	1500	F	SCD 10
225	MV3S225RBC	NJ1	39.50	34.00	51.50	1700	F	SCD 10
300	MV3S300RBC	NJ1	39.50	34.00	51.50	1900	F	SCD 10
500	MV3S500RBC	NJ2	48.50	38.40	59.00	3000	F	SCD 10
750	MV3S750RBC	NJ6	64.00	44.40	71.00	4200	F	SCD 10
1000	MV3S1000RBC	NJ6	64.00	44.40	71.00	4800	F	SCD 10
1250	MV3S1250RBC	NJ6	64.00	44.40	71.00	6200	F	SCD 10
1500	MV3S1500RBC	NJ7	64.00	51.40	75.00	6600	F	SCD 10

For shielded units, please replace the letter "C" with a "K" in the above part numbers.

*WALL MOUNTING KIT AND/OR DRIP PLATE KIT REQUIRED.
REFER TO PAGES 271 TO 273 FOR DETAILS.

2400 Delta Primary Volts

480Y/277 Secondary Volts

60 Hz

kVA	Catalog Number	Case Style (Pages 260 - 267)	Approx. Dimensions (Inches)			Approx. Weight (Lbs)	Mtg Type W - Wall F - Floor	Wiring Diagram (Pages 276 - 288)
			Width	Depth	Height			
15	MV3S015RKCN	NH6	23.90	25.00	28.75	400	F or W *	SCD 8
30	MV3S030RKCN	NH6	23.90	25.00	28.75	500	F or W *	SCD 10
45	MV3S045RKCN	NH3	26.00	25.00	38.00	600	F or W *	SCD 10
75	MV3S075RKCN	NH4	32.00	29.50	41.00	900	F	SCD 10
112.5	MV3S112RKCN	NH4	32.00	29.50	41.00	1100	F	SCD 10
150	MV3S150RKCN	NJ1	39.50	34.00	51.50	1500	F	SCD 10
225	MV3S225RKC	NJ1	39.50	34.00	51.50	1600	F	SCD 10
300	MV3S300RKC	NJ1	39.50	34.00	51.50	1900	F	SCD 10
500	MV3S500RKC	NJ2	48.50	38.40	59.00	3000	F	SCD 10
750	MV3S750RKC	NJ6	64.00	44.40	71.00	4200	F	SCD 10
1000	MV3S1000RKC	NJ6	64.00	44.40	71.00	4800	F	SCD 10
1250	MV3S1250RKC	NJ6	64.00	44.40	71.00	6200	F	SCD 10
1500	MV3S1500RKC	NJ7	64.00	51.40	75.00	6600	F	SCD 10

For shielded units, please replace the letter "C" with a "K" in the above part numbers.

*WALL MOUNTING KIT AND/OR DRIP PLATE KIT REQUIRED.
REFER TO PAGES 271 TO 273 FOR DETAILS.

2400 Delta Primary Volts

600Y/347 Secondary Volts

60 Hz

kVA	Catalog Number	Case Style (Pages 260 - 267)	Approx. Dimensions (Inches)			Approx. Weight (Lbs)	Mtg Type W - Wall F - Floor	Wiring Diagram (Pages 276 - 288)
			Width	Depth	Height			
15	MV3S015RPCN	NH6	23.90	25.00	28.75	400	F or W *	SCD 8
30	MV3S030RPCN	NH6	23.90	25.00	28.75	500	F or W *	SCD 10
45	MV3S045RPCN	NH3	26.00	25.00	38.00	600	F or W *	SCD 10
75	MV3S075RPCN	NH4	32.00	29.50	41.00	900	F	SCD 10
112.5	MV3S112RPCN	NH4	32.00	29.50	41.00	1100	F	SCD 10
150	MV3S150RPCN	NJ1	39.50	34.00	51.50	1500	F	SCD 10
225	MV3S225RPC	NJ1	39.50	34.00	51.50	1600	F	SCD 10
300	MV3S300RPC	NJ1	39.50	34.00	51.50	1900	F	SCD 10
500	MV3S500RPC	NJ2	48.50	38.40	59.00	2900	F	SCD 10
750	MV3S750RPC	NJ6	64.00	44.40	71.00	4200	F	SCD 10
1000	MV3S1000RPC	NJ6	64.00	44.40	71.00	4800	F	SCD 10
1250	MV3S1250RPC	NJ6	64.00	44.40	71.00	6200	F	SCD 10
1500	MV3S1500RPC	NJ7	64.00	51.40	75.00	6600	F	SCD 10

For shielded units, please replace the letter "C" with a "K" in the above part numbers.

*WALL MOUNTING KIT AND/OR DRIP PLATE KIT REQUIRED.
REFER TO PAGES 271 TO 273 FOR DETAILS.

FOR TERMINATION DETAILS SEE PAGE 275

FOR ACCESSORIES SEE PAGES 271 TO 274



COPPER WOUND, THREE PHASE, NEMA 3R STYLE ENCLOSURE



4160 Delta Primary Volts

208Y/120 Secondary Volts

60 Hz

kVA	Catalog Number	Case Style (Pages 260 - 267)	Approx. Dimensions (Inches)			Approx. Weight (Lbs)	Mtg Type W - Wall F - Floor	Wiring Diagram (Pages 276 - 288)
			Width	Depth	Height			
15	MV3S015SBCN	NH6	23.90	25.00	28.75	400	F or W *	SCD 8
30	MV3S030SBCN	NH6	23.90	25.00	28.75	500	F or W *	SCD 10
45	MV3S045SBCN	NH3	26.00	25.00	38.00	600	F or W *	SCD 10
75	MV3S075SBCN	NH4	32.00	29.50	41.00	900	F	SCD 10
112.5	MV3S112SBCN	NH4	32.00	29.50	41.00	1100	F	SCD 10
150	MV3S150SBCN	NJ1	39.50	34.00	51.50	1500	F	SCD 10
225	MV3S225SBCN	NJ1	39.50	34.00	51.50	1700	F	SCD 10
300	MV3S300SBC	NJ1	39.50	34.00	51.50	1900	F	SCD 10
500	MV3S500SBC	NJ2	48.50	38.40	59.00	3000	F	SCD 10
750	MV3S750SBC	NJ6	64.00	44.40	71.00	4200	F	SCD 10
1000	MV3S1000SBC	NJ6	64.00	44.40	71.00	4800	F	SCD 10
1250	MV3S1250SBC	NJ6	64.00	44.40	71.00	6200	F	SCD 10
1500	MV3S1500SBC	NJ7	64.00	51.40	75.00	6600	F	SCD 10

For shielded units, please replace the letter "C" with a "K" in the above part numbers.

*WALL MOUNTING KIT AND/OR DRIP PLATE KIT REQUIRED. REFER TO PAGES 271 TO 273 FOR DETAILS.

4160 Delta Primary Volts

480Y/277 Secondary Volts

60 Hz

kVA	Catalog Number	Case Style (Pages 260 - 267)	Approx. Dimensions (Inches)			Approx. Weight (Lbs)	Mtg Type W - Wall F - Floor	Wiring Diagram (Pages 276 - 288)
			Width	Depth	Height			
15	MV3S015SKCN	NH6	23.90	25.00	28.75	400	F or W *	SCD 8
30	MV3S030SKCN	NH6	23.90	25.00	28.75	500	F or W *	SCD 10
45	MV3S045SKCN	NH3	26.00	25.00	38.00	600	F or W *	SCD 10
75	MV3S075SKCN	NH4	32.00	29.50	41.00	900	F	SCD 10
112.5	MV3S112SKCN	NH4	32.00	29.50	41.00	1100	F	SCD 10
150	MV3S150SKCN	NJ1	39.50	34.00	51.50	1500	F	SCD 10
225	MV3S225SKCN	NJ1	39.50	34.00	51.50	1600	F	SCD 10
300	MV3S300SKC	NJ1	39.50	34.00	51.50	1900	F	SCD 10
500	MV3S500SKC	NJ2	48.50	38.40	59.00	3000	F	SCD 10
750	MV3S750SKC	NJ6	64.00	44.40	71.00	4200	F	SCD 10
1000	MV3S1000SKC	NJ6	64.00	44.40	71.00	4800	F	SCD 10
1250	MV3S1250SKC	NJ6	64.00	44.40	71.00	6200	F	SCD 10
1500	MV3S1500SKC	NJ7	64.00	51.40	75.00	6600	F	SCD 10

For shielded units, please replace the letter "C" with a "K" in the above part numbers.

*WALL MOUNTING KIT AND/OR DRIP PLATE KIT REQUIRED. REFER TO PAGES 271 TO 273 FOR DETAILS.

4160 Delta Primary Volts

600Y/347 Secondary Volts

60 Hz

kVA	Catalog Number	Case Style (Pages 260 - 267)	Approx. Dimensions (Inches)			Approx. Weight (Lbs)	Mtg Type W - Wall F - Floor	Wiring Diagram (Pages 276 - 288)
			Width	Depth	Height			
15	MV3S015SPCN	NH6	23.90	25.00	28.75	400	F or W *	SCD 8
30	MV3S030SPCN	NH6	23.90	25.00	28.75	500	F or W *	SCD 10
45	MV3S045SPCN	NH3	26.00	25.00	38.00	600	F or W *	SCD 10
75	MV3S075SPCN	NH4	32.00	29.50	41.00	900	F	SCD 10
112.5	MV3S112SPCN	NH4	32.00	29.50	41.00	1100	F	SCD 10
150	MV3S150SPCN	NJ1	39.50	34.00	51.50	1500	F	SCD 10
225	MV3S225SPCN	NJ1	39.50	34.00	51.50	1600	F	SCD 10
300	MV3S300SPC	NJ1	39.50	34.00	51.50	1900	F	SCD 10
500	MV3S500SPC	NJ2	48.50	38.40	59.00	2900	F	SCD 10
750	MV3S750SPC	NJ6	64.00	44.40	71.00	4200	F	SCD 10
1000	MV3S1000SPC	NJ6	64.00	44.40	71.00	4800	F	SCD 10
1250	MV3S1250SPC	NJ6	64.00	44.40	71.00	6200	F	SCD 10
1500	MV3S1500SPC	NJ7	64.00	51.40	75.00	6600	F	SCD 10

For shielded units, please replace the letter "C" with a "K" in the above part numbers.

*WALL MOUNTING KIT AND/OR DRIP PLATE KIT REQUIRED. REFER TO PAGES 271 TO 273 FOR DETAILS.

FOR TERMINATION DETAILS SEE PAGE 275

FOR ACCESSORIES SEE PAGES 271 TO 274



SECTION 11



GENERAL INFORMATION

Enclosure Drawings, Connection Diagrams, Termination Details, Alpha-Numeric Part Number Index

Enclosure Dimensional Drawings	260
Conduit Size vs. Knockout Size Reference Table	264
Accessories - for General Purpose Transformers	271
Termination Details	275
Electrical Connection Diagrams	276
Alpha-Numeric Part Number Index	291
HPS Transformer Literature Request Form	316

GENERAL INFORMATION

NEMA 3R ENCLOSURE DIMENSIONAL DRAWINGS

'NH' SERIES ENCLOSURES

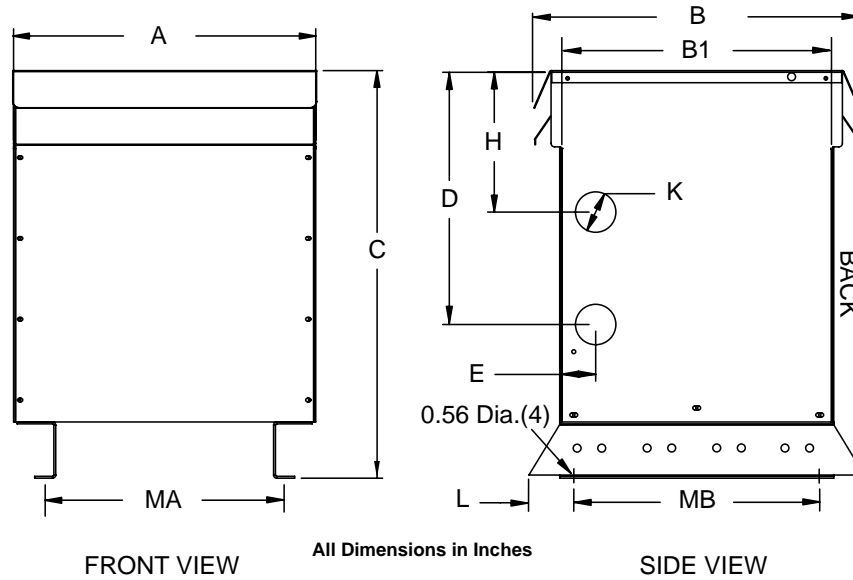

Case Style	Dimensions in Inches										
	A	B	B ¹	C	D	E	H	K ¹	L	MA	MB
NH3	26.00	25.00	24.00	38.00	24.00	2.50	14.00	2.00 X 3.00	2.50	21.50	19.00
NH4	32.00	29.50	28.50	41.00	24.00	2.50	12.00	2.00 X 3.00	2.50	23.50	23.50

Note: Mounting hole dimension is 0.56" diameter.

OPTIONAL NEMA 4, 12 AND STAINLESS STEEL ENCLOSURES ARE AVAILABLE.

¹ Knockout (K) sizes are actual diameters of knockout, not conduit sizes. Refer to table on page 260 for conduit sizes.

SEE PAGE 266 & 267 FOR DETAILS.

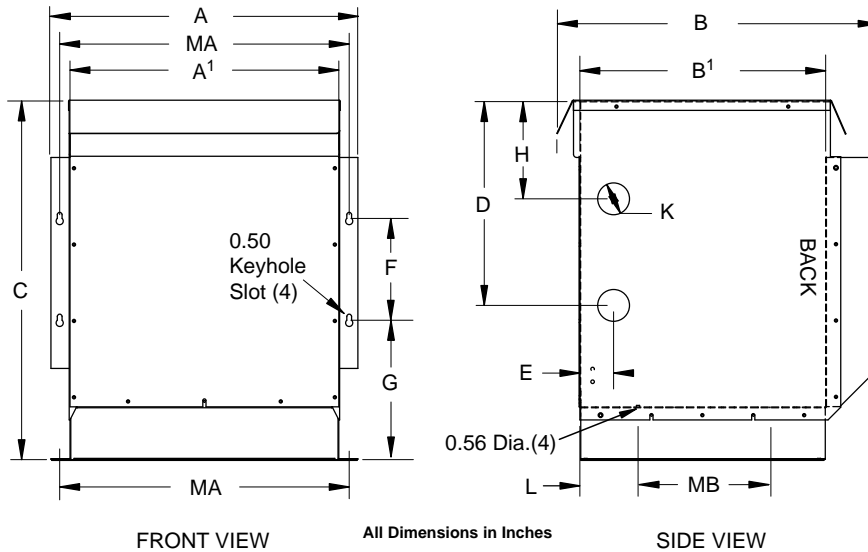

Case Style	Dimensions in Inches													
	A	A ¹	B	B ¹	C	D	E	F	G	H	K ¹	L	MA	MB
NH5	19.40	16.75	20.20	15.00	21.50	12.00	2.00	7.00	7.81	6.00	1.38 X 1.75	2.80	18.00	9.00
NH6	23.90	21.50	25.00	19.50	28.75	17.00	2.00	8.00	10.29	8.50	1.75 X 2.50	5.20	22.75	9.00

Note: Mounting hole dimension is 0.56" diameter.

OPTIONAL NEMA 4, 12 AND STAINLESS STEEL ENCLOSURES ARE AVAILABLE.

¹ Knockout (K) sizes are actual diameters of knockout, not conduit sizes. Refer to table on page 260 for conduit sizes.

SEE PAGE 266 & 267 FOR DETAILS.

GENERAL INFORMATION



GENERAL INFORMATION

NEMA 3R ENCLOSURE DIMENSIONAL DRAWINGS

'NJ' SERIES ENCLOSURES

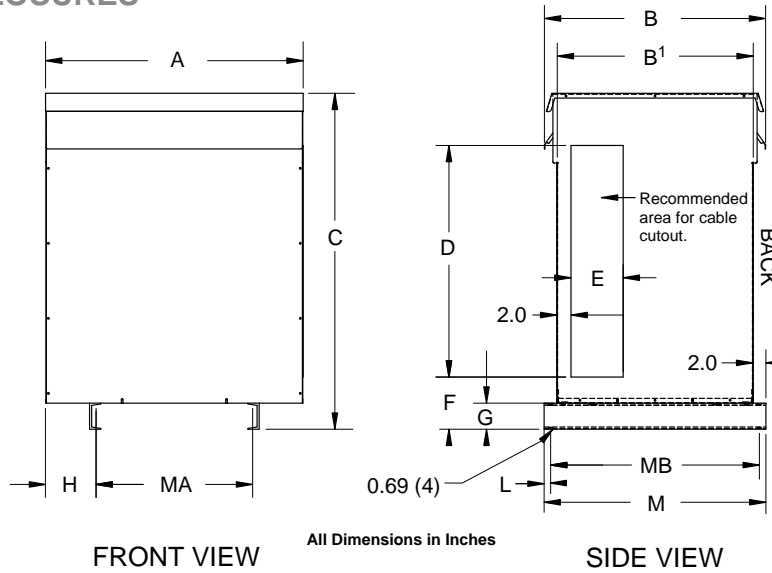

Case Style	Dimensions in Inches												
	A	B	B'	C	D	E	F	G	H	L	M	MA	MB
NJ1	39.50	34.00	30.00	51.50	35.50	6.00	8.00	4.00	7.75	1.00	34.00	24.00	32.00
NJ2	48.50	38.40	34.00	59.00	40.00	8.00	8.00	4.00	10.50	1.00	38.00	27.50	36.00
NJ4	32.00	32.50	28.50	50.00	34.00	8.00	8.00	4.00	5.00	1.00	32.50	22.00	30.50

Note: Mounting hole dimension is 0.69" diameter.

OPTIONAL NEMA 4, 12 AND STAINLESS STEEL ENCLOSURES ARE AVAILABLE.
SEE PAGE 266 & 267 FOR DETAILS.

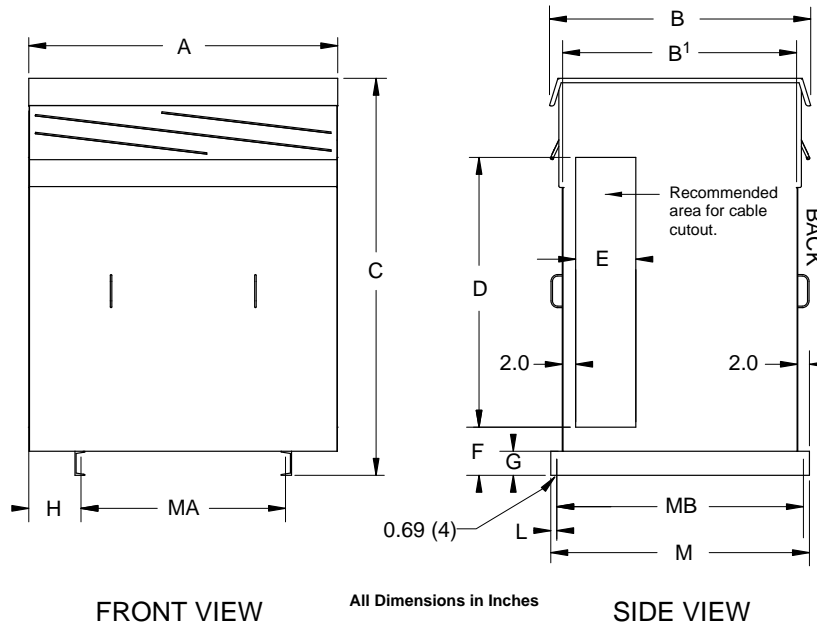

Case Style	Dimensions in Inches												
	A	B	B'	C	D	E	F	G	H	L	M	MA	MB
NJ3	51.50	43.40	39.00	66.00	47.00	10.00	8.00	4.00	8.75	1.00	43.00	34.00	41.00
NJ6	64.00	44.40	40.00	71.00	50.00	11.50	9.00	5.00	12.00	1.00	44.00	40.00	42.00
NJ7	64.00	51.40	47.00	75.00	54.00	11.50	9.00	5.00	12.00	1.00	51.00	40.00	49.00

Note: Mounting hole dimension is 0.69" diameter.

OPTIONAL NEMA 4, 12 AND STAINLESS STEEL ENCLOSURES ARE AVAILABLE.
SEE PAGE 266 & 267 FOR DETAILS.

GENERAL INFORMATION



GENERAL INFORMATION

NEMA 3R ENCLOSURE DIMENSIONAL DRAWINGS

'NQ' SERIES ENCLOSURES

Figure 1

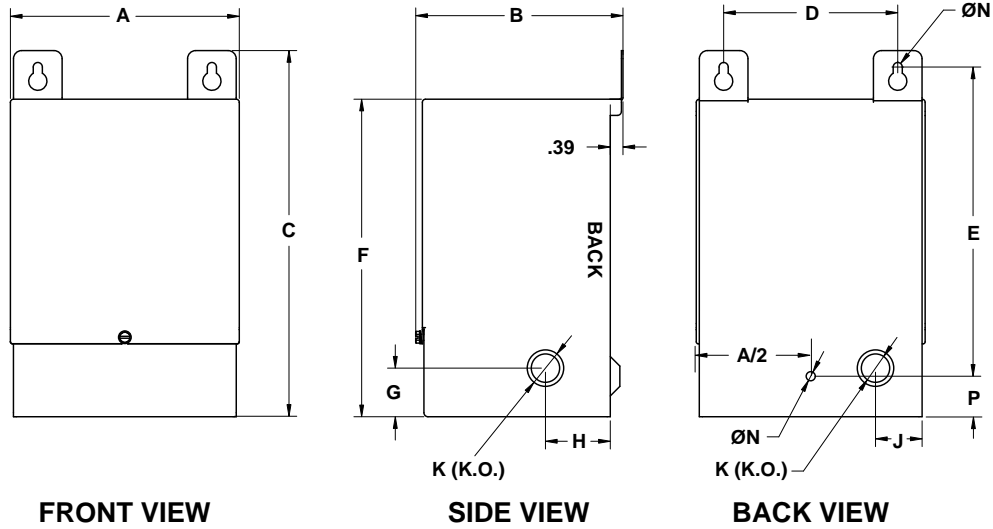

Case Style	Fig #	Dimensions in Inches														
		A	B	C	D	E	F	G	H	J	K ¹	L	M	N	P	R
NQ0	1	3.75	5.25	7.25	2.50	5.63	6.25	1.50	2.00	--	0.88	--	--	0.22	1.25	--
NQ1	1	4.50	5.75	7.25	3.13	5.63	6.25	1.50	2.00	0.81	0.88	--	--	0.22	1.25	--
NQ2	1	5.00	4.75	9.25	3.88	7.75	8.25	1.50	2.00	1.00	0.88 X 1.13 X 1.38	--	--	0.22	1.25	--
NQ3	1	5.88	5.50	10.50	4.13	8.25	9.00	1.50	2.00	1.25	0.88 X 1.13 X 1.38	--	--	0.28	1.25	--
NQ4	1	7.00	6.50	11.75	5.38	9.50	10.25	1.75	2.00	1.50	0.88 X 1.13 X 1.38	--	--	0.28	1.25	--
NQ5	2	10.00	7.75	17.25	7.38	15.38	15.25	2.375	2.00	4.00	1.13 X 1.38	6.00	0.75	0.44	1.25	1.68
NQ6A	2	12.25	9.25	17.63	9.38	14.88	15.56	2.00	2.00	5.00	1.38 X 2.50	8.00	0.75	0.44	2.00	1.68
NQ6	2	12.25	9.25	20.88	9.38	18.13	18.88	2.00	2.00	5.00	1.38 X 2.50	8.00	0.75	0.44	2.00	1.68
NQ7	2	14.50	10.75	21.38	11.63	18.63	19.38	2.00	2.00	6.00	1.38 X 2.50	10.00	0.75	0.44	2.00	1.81
NQ8	2	14.50	10.75	27.38	11.13	24.50	24.88	2.00	2.00	6.00	1.38 X 2.50	10.00	0.75	0.56	2.00	1.81

¹ Knockout (K) sizes are actual diameters of knockout, not conduit sizes. Refer to table on page 260 for conduit sizes.

OPTIONAL STAINLESS STEEL ENCLOSURES ARE AVAILABLE.

Figure 2

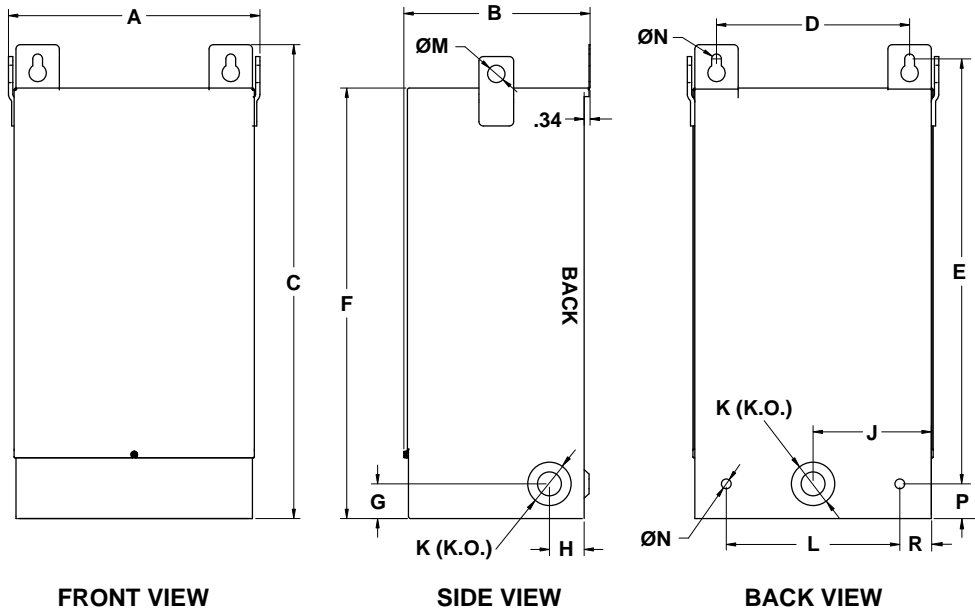

GENERAL INFORMATION



GENERAL INFORMATION

NEMA 3R ENCLOSURE DIMENSIONAL DRAWINGS

'NQT & NQS' SERIES ENCLOSURES

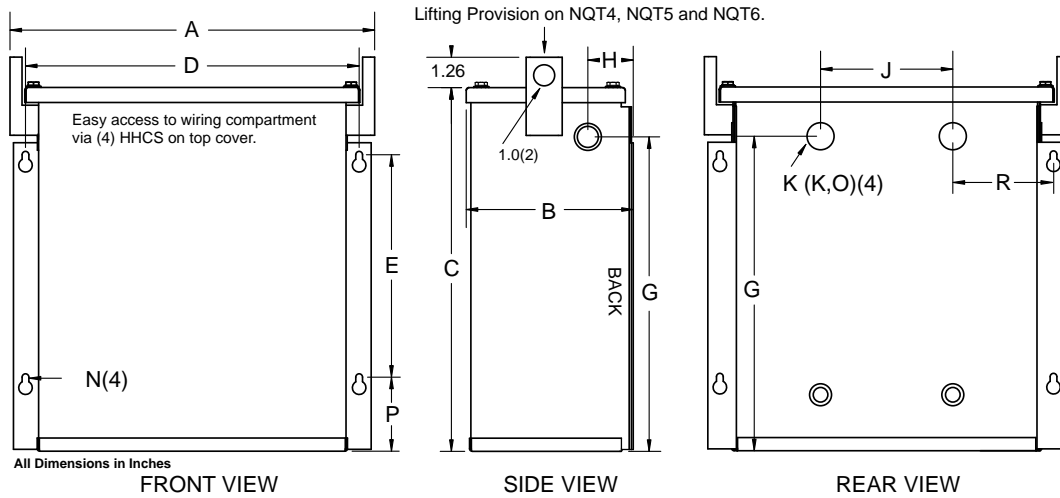

Figure 1

Case Style	Fig #	Dimensions in Inches															
		A	B	C	D	E	F	G	H	J	K ¹	L	M	N	P	R	
NQT2	1	9.38	4.94	8.63	8.38	4.00	-	7.06	2.38	4.50	0.88 X 1.13	-	-	0.28	1.81	2.44	
NQT3	1	12.38	5.44	11.13	11.38	6.50	-	9.50	2.38	5.50	0.88 X 1.13	-	-	0.28	1.81	3.44	
NQT4	1	15.19	6.94	15.13	13.88	9.25	-	13.56	1.88	5.50	0.88 X 1.13	-	-	0.28	3.06	4.19	
NQT5	1	16.63	10.25	16.63	14.50	8.25	-	13.88	2.69	10.00	1.38 X 1.75	-	-	0.41	4.50	2.25	
NQT6	1	19.25	10.44	16.63	17.50	8.25	-	13.56	2.69	12.50	1.38 X 2.50	-	-	0.41	4.50	2.50	
NQT7	2	20.25	13.00	23.38	12.00	11.75	11.38	17.94	2.50	13.75	1.38 X 2.50	4.25	17.94	0.56	-	2.13	
NQT8	2	22.25	13.00	28.38	14.00	11.75	11.38	21.94	2.50	15.75	1.38 X 2.50	4.25	21.94	0.56	-	2.13	
NQT9	2	31.25	16.00	29.88	18.00	14.75	14.13	23.94	2.75	22.75	2.00 X 3.00	6.50	23.94	0.56	-	3.13	
NQT9A	2	34.63	18.50	36.75	22.50	17.25	16.50	30.38	4.69	27.25	2.00 X 3.00	6.50	30.38	0.56	-	3.31	
NQS10	2	21.88	18.50	31.00	13.50	17.25	16.50	24.63	4.91	13.13	1.75 X 2.50	6.50	24.63	0.56	-	4.00	
NQT10	3	38.44	26.00	39.13	23.50	24.00	20.80	32.50	6.40	24.75	2.50 X 3.63	8.00	32.50	0.69	-	6.84	
NQT11	3	37.38	30.00	45.63	23.50	28.00	22.00	39.00	6.95	24.75	2.50 X 3.63	8.00	39.00	0.69	-	6.31	

¹ Knockout (K) sizes are actual diameters of knockout, not conduit sizes. Refer to table on page 260 for conduit sizes.

OPTIONAL STAINLESS STEEL ENCLOSURES ARE AVAILABLE.

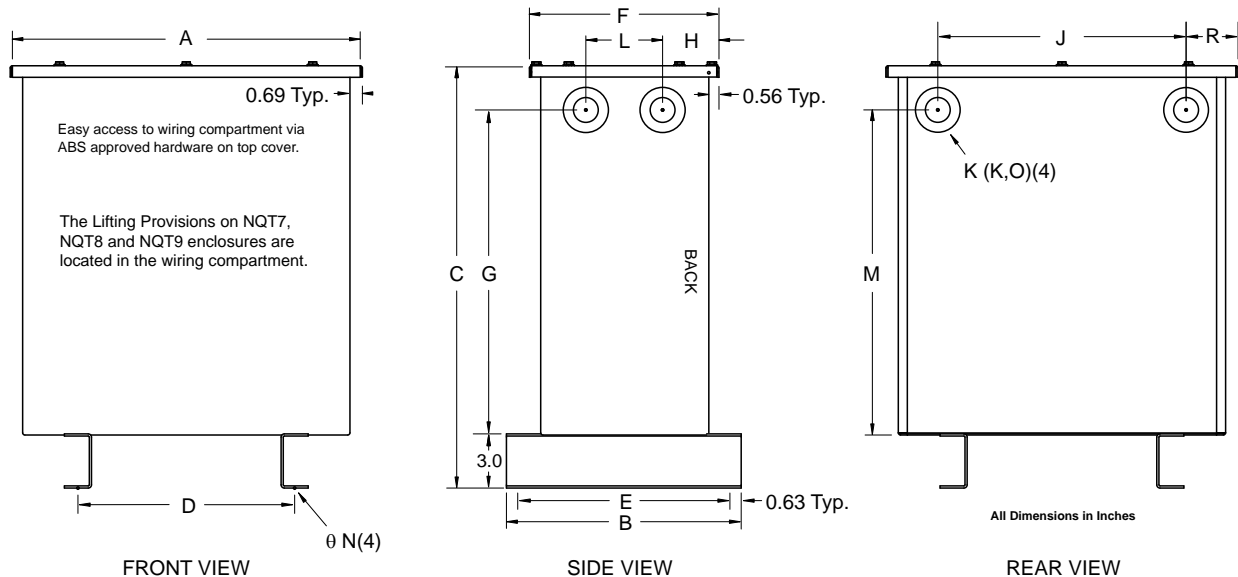

Figure 2



GENERAL INFORMATION

NEMA 3R ENCLOSURE DIMENSIONAL DRAWINGS CONTINUED 'NQT & NQS' SERIES ENCLOSURES

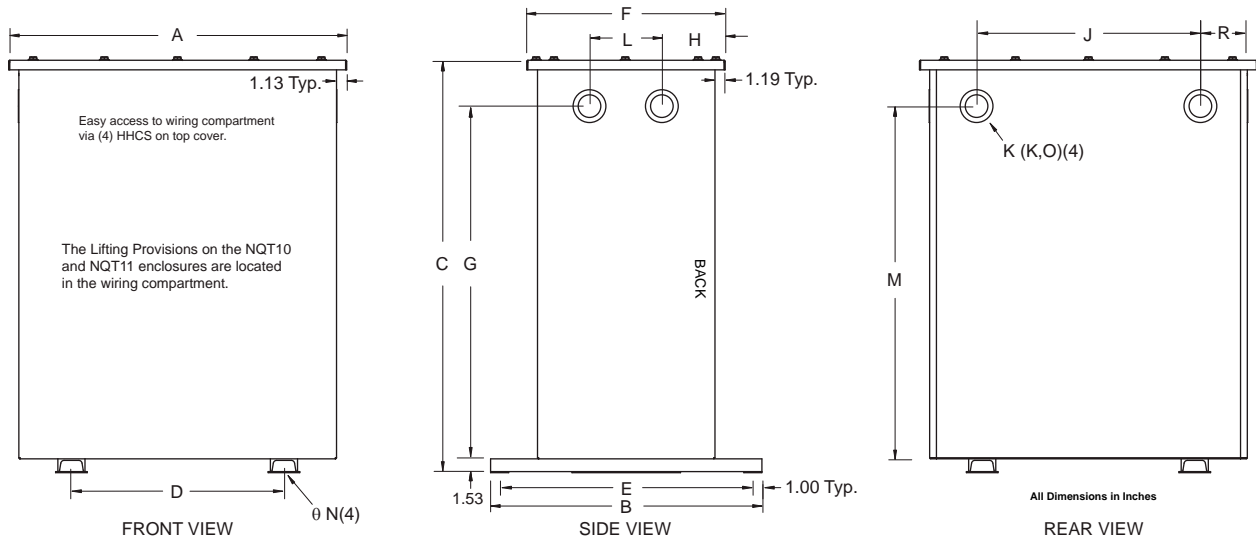
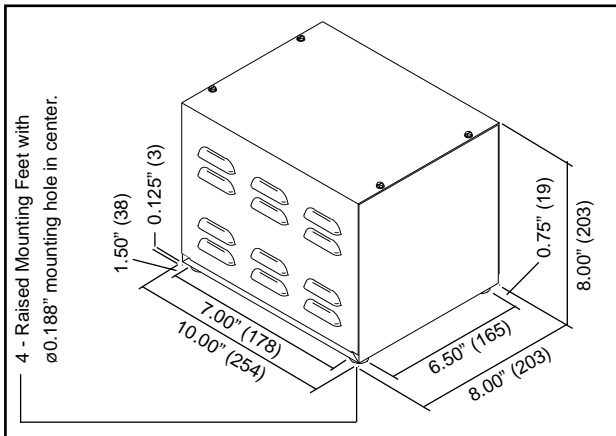

Figure 3

NEMA 2 ENCLOSURE DIMENSIONAL DRAWINGS

'N1' SERIES ENCLOSURE



'N2' SERIES ENCLOSURE

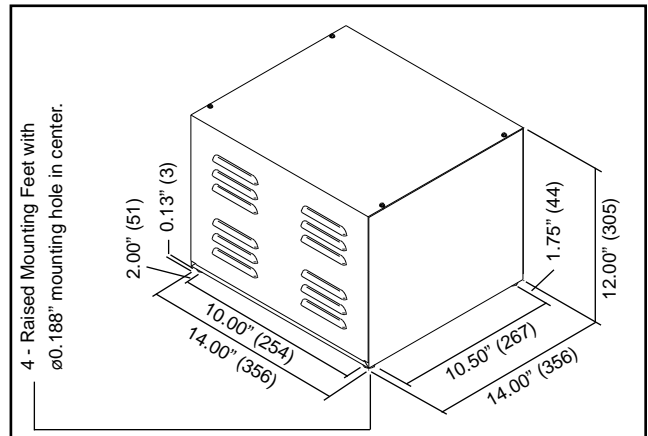

Conduit Size vs. Actual Knockout Size Reference Table

Standard Conduit Size	Actual Knockout Diameter
1/2"	7/8"
3/4"	1 1/8"
1"	1 3/8"
1 1/4"	1 3/4"
1 1/2"	2"
2"	2 1/2"
2 1/2"	3"
3"	3 5/8"
3 1/2"	4 1/8"

GENERAL
INFORMATION



GENERAL INFORMATION

TYPE 3RE ENHANCED ENCLOSURE DIMENSIONAL DRAWINGS 'NH' SERIES ENCLOSURES

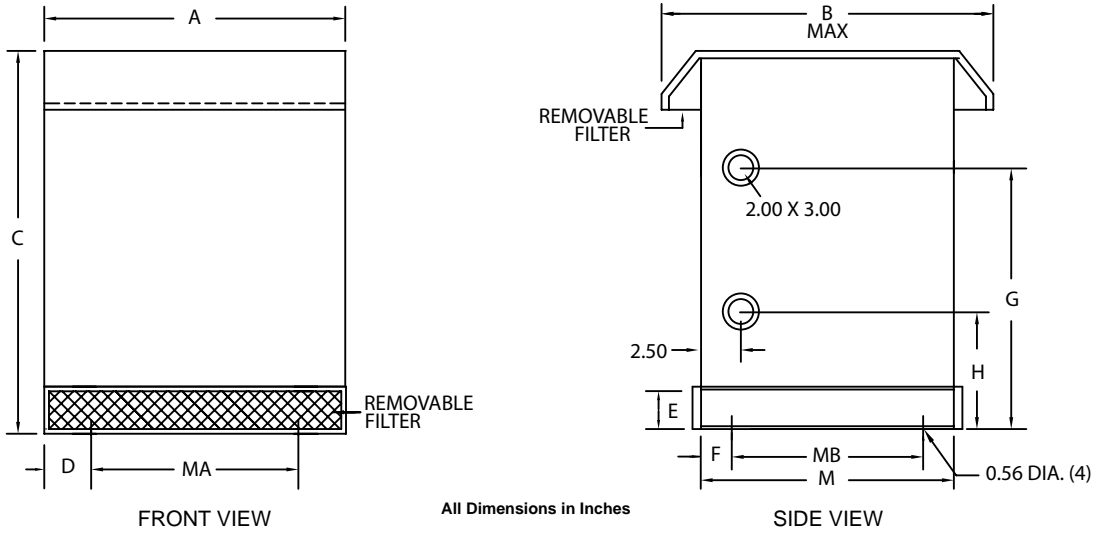

Case Style	Dimensions in Inches										
	A	B	C	D	E	F	G	H	MA	MB	M
NH3-N3RE	26.00	38.00	42.00	2.25	8.00	0.75	26.00	18.00	21.50	19.00	20.63
NH4-N3RE	32.00	42.00	45.00	4.25	8.00	0.75	29.00	18.00	23.50	23.50	25.13

'NJ' SERIES ENCLOSURES

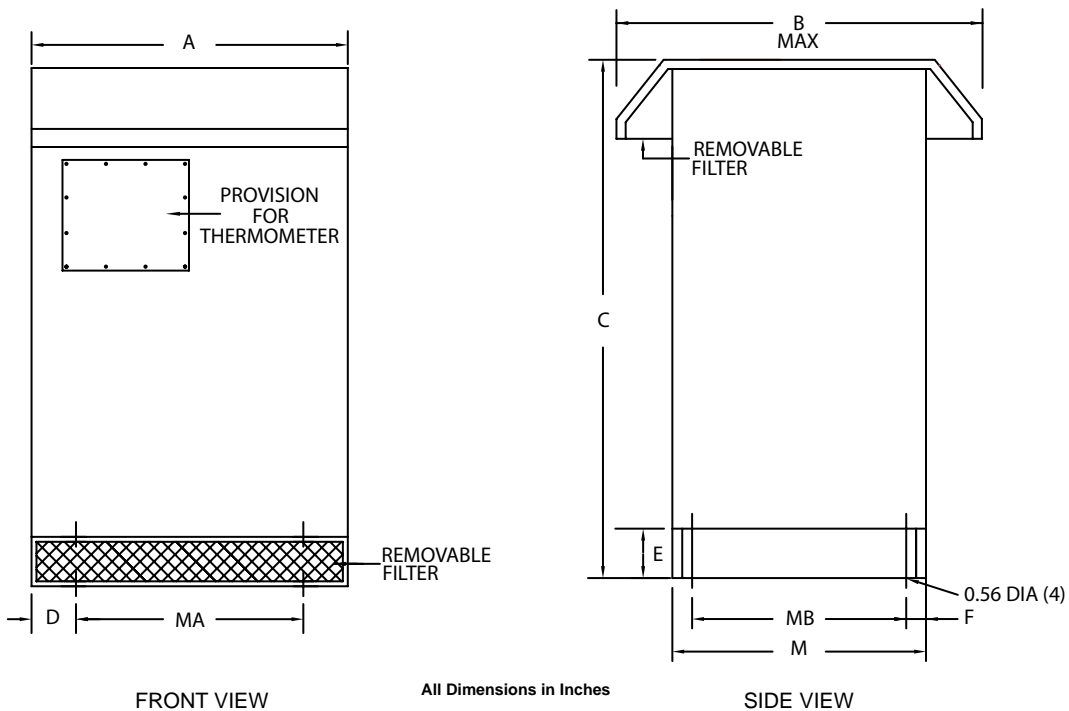

Case Style	Dimensions in Inches									
	A	B	C	D	E	F	MA	MB	M	
NJ1-N3RE	39.50	55.00	57.50	7.63	10.00	1.00	24.00	32.00	34.00	
NJ2-N3RE	48.50	60.00	65.00	10.38	10.00	1.00	27.50	36.00	38.00	
NJ3-N3RE	51.50	65.00	72.00	8.52	10.00	1.00	34.00	41.00	43.00	
NJ6-N3RE	64.00	70.00	83.00	12.00	12.00	1.00	40.00	42.00	44.00	
NJ7-N3RE	64.00	77.00	83.00	12.00	12.00	1.00	40.00	49.00	51.00	

GENERAL
INFORMATION



GENERAL INFORMATION

OPTIONAL NEMA 4 & 12 ENCLOSURE DIMENSIONAL DRAWINGS 'NH-N4 & NH-N12' SERIES ENCLOSURES

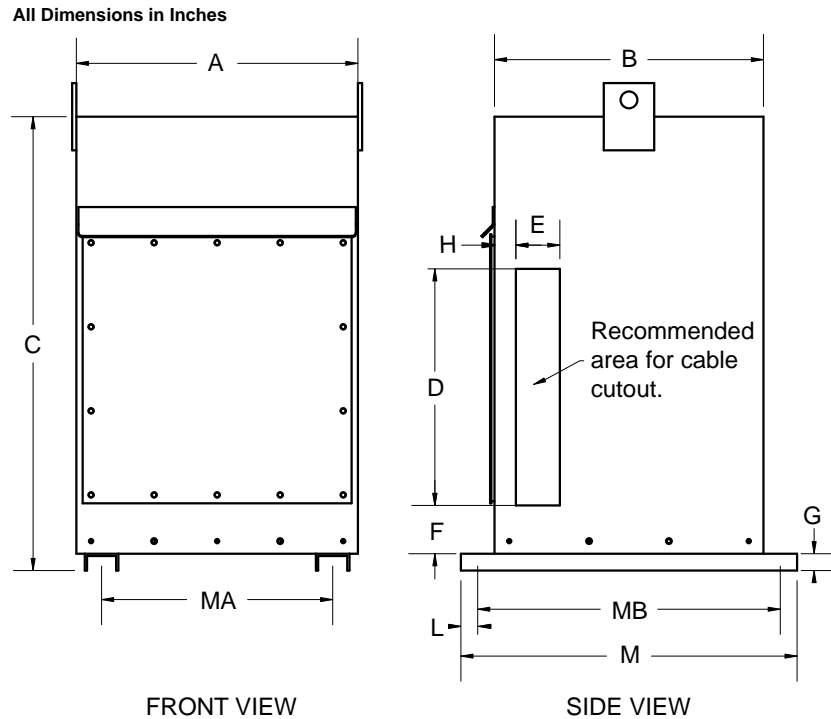

Case Style	Dimensions in Inches											
	A	B	C	D	E	F	G	H	L	M	MA	MB
NH5-N4, NH5-N12	16.75	16.00	27.00	16.00	4.00	4.00	1.00	2.00	1.00	20.00	13.75	18.00
NH6-N4, NH6-N12	21.50	21.00	41.00	24.00	5.00	4.00	1.00	2.00	1.00	25.00	17.00	23.00
NH3-N4, NH3-N12	28.00	23.00	55.50	32.00	6.00	4.00	1.50	2.00	1.00	27.00	21.50	25.00
NH4-N4, NH4-N12	34.00	27.00	61.50	36.00	7.00	4.00	1.50	2.00	1.00	31.00	23.50	29.00

Note: Mounting hole dimension is 0.69" diameter.

GENERAL INFORMATION

Optional NEMA 4 & 12 Stainless Steel Enclosures

Optional NEMA 4 and 12 rated stainless steel enclosures are available and are designed using either type 304 or 316 stainless steel in accordance with ANSI, NEMA, UL and ABS requirements for indoor, outdoor and marine duty applications.



GENERAL INFORMATION

OPTIONAL NEMA 4 & 12 ENCLOSURE DIMENSIONAL DRAWINGS

'NJ-N4 & NJ-N12' SERIES ENCLOSURES

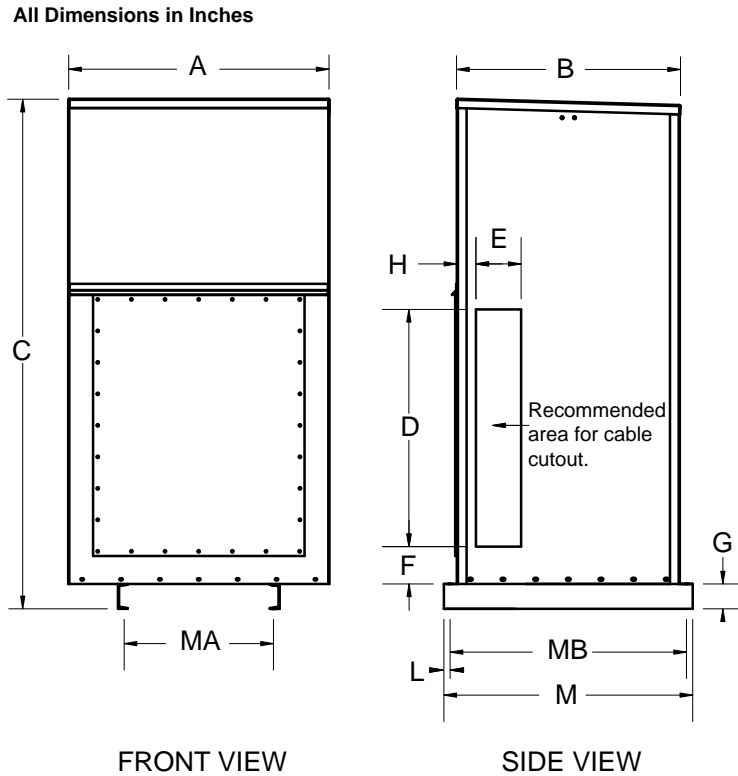

Case Style	Dimensions in Inches											
	A	B	C	D	E	F	G	H	L	M	MA	MB
NJ1-N4, NJ1-N12	42.00	36.00	82.00	40.00	8.00	6.00	4.00	3.00	1.00	40.00	24.00	38.00

Note: Mounting hole dimension is 0.69" diameter.

Optional NEMA 4 & 12 Stainless Steel Enclosures

Optional NEMA 4 and 12 rated stainless steel enclosures are available and are designed using either type 304 or 316 stainless steel in accordance with ANSI, NEMA, UL and ABS requirements for indoor, outdoor and marine duty applications.

GENERAL
INFORMATION



GENERAL INFORMATION

NEMA 3R ENCLOSURE DIMENSIONAL DRAWINGS

'PPE1 - PPE5' SERIES ENCLOSURES

PPE1

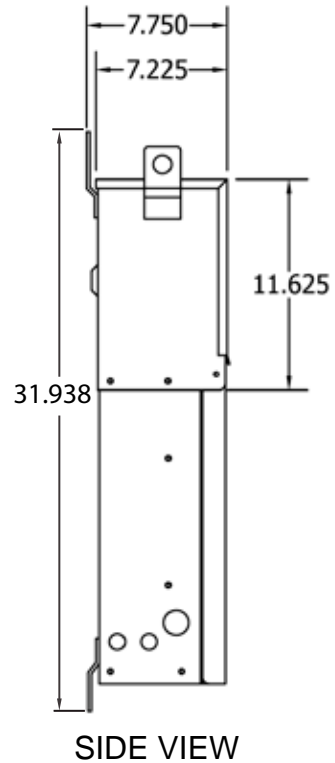
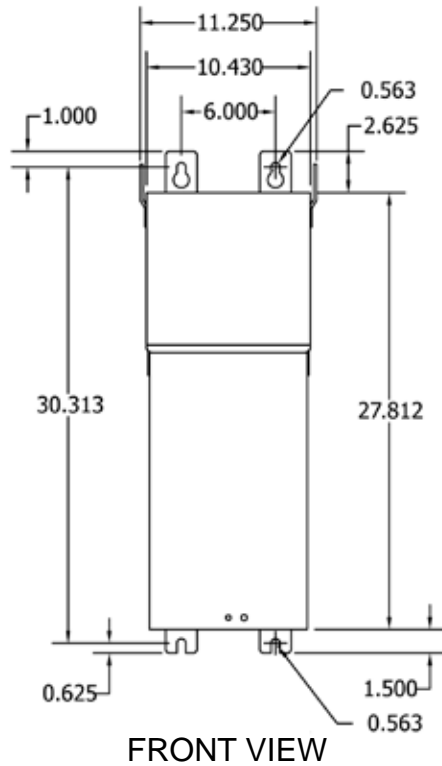

PPE2

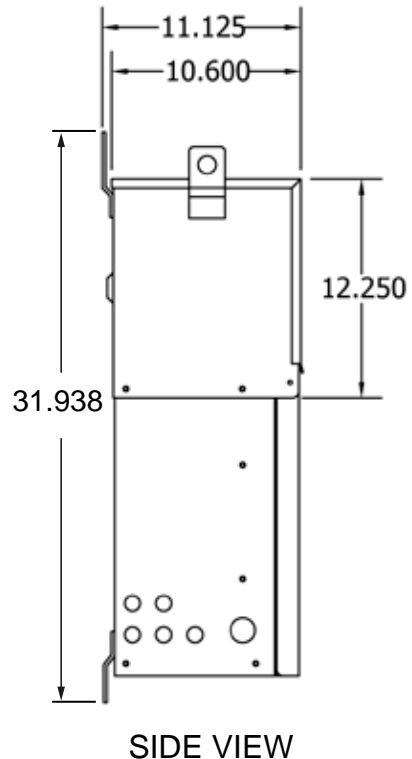
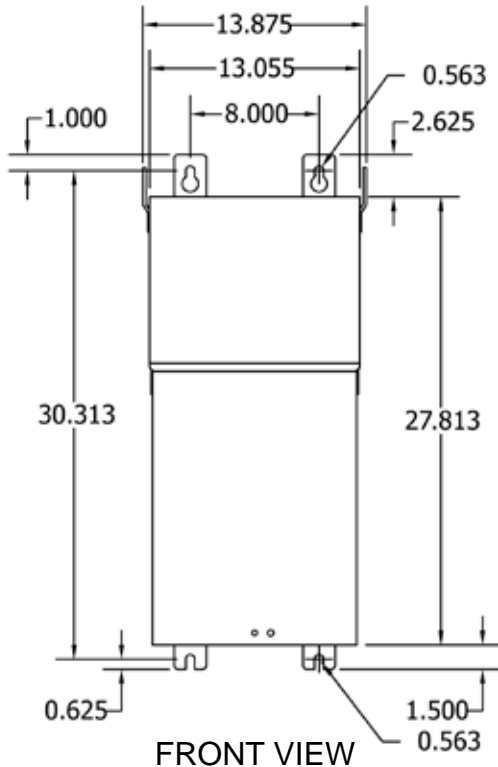

GENERAL
INFORMATION



GENERAL INFORMATION

NEMA 3R ENCLOSURE DIMENSIONAL DRAWINGS

'PPE1 - PPE5' SERIES ENCLOSURES CONTINUED

PPE3

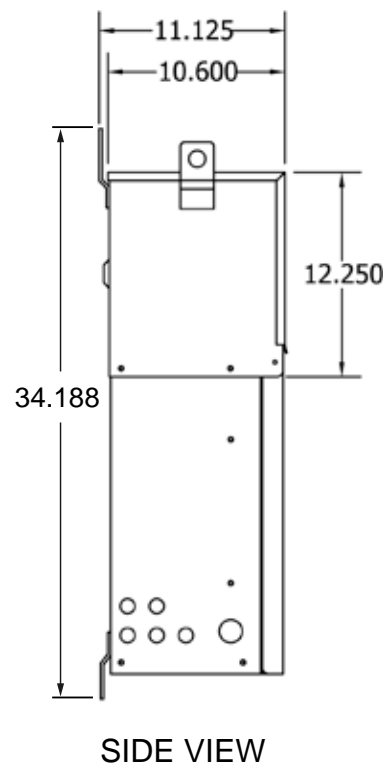
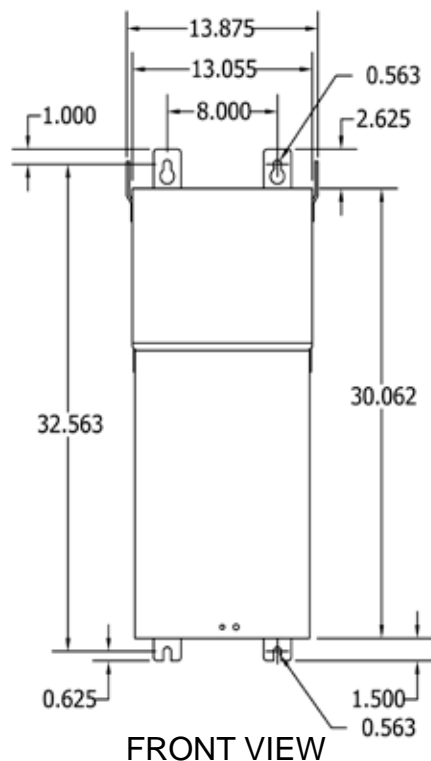

PPE4

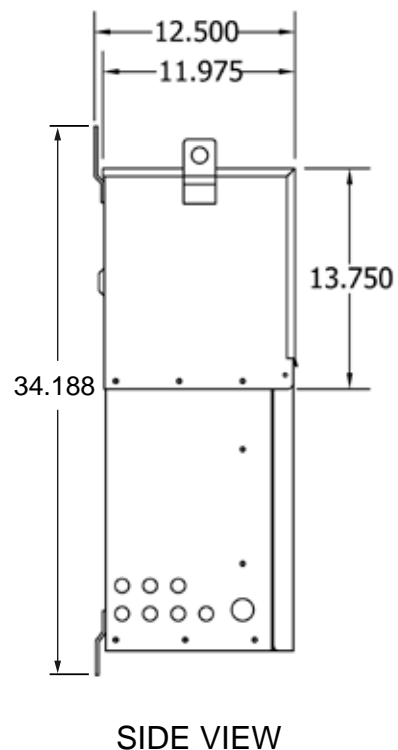
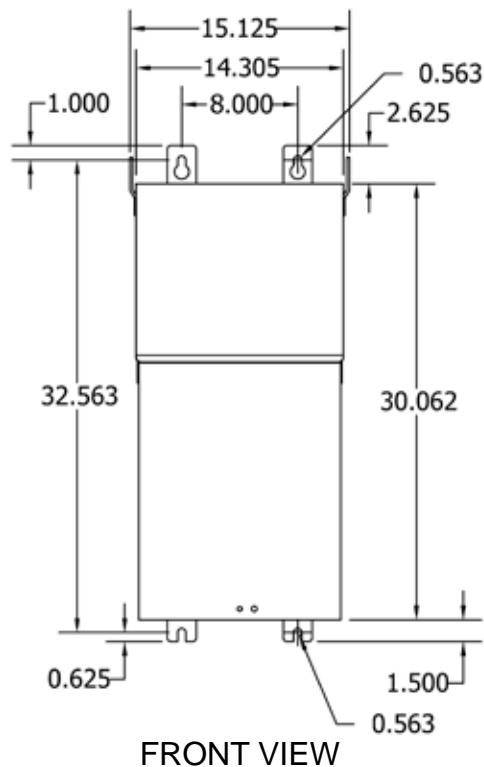

GENERAL
INFORMATION



GENERAL INFORMATION

NEMA 3R ENCLOSURE DIMENSIONAL DRAWINGS

'PPE1 - PPE5' SERIES ENCLOSURES CONTINUED

PPE5

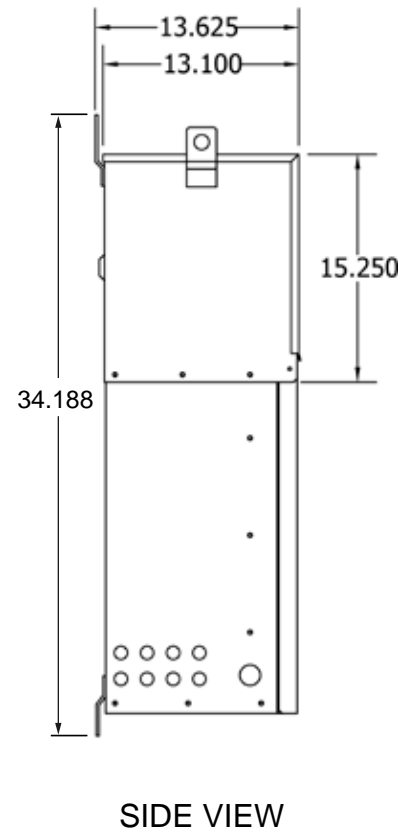
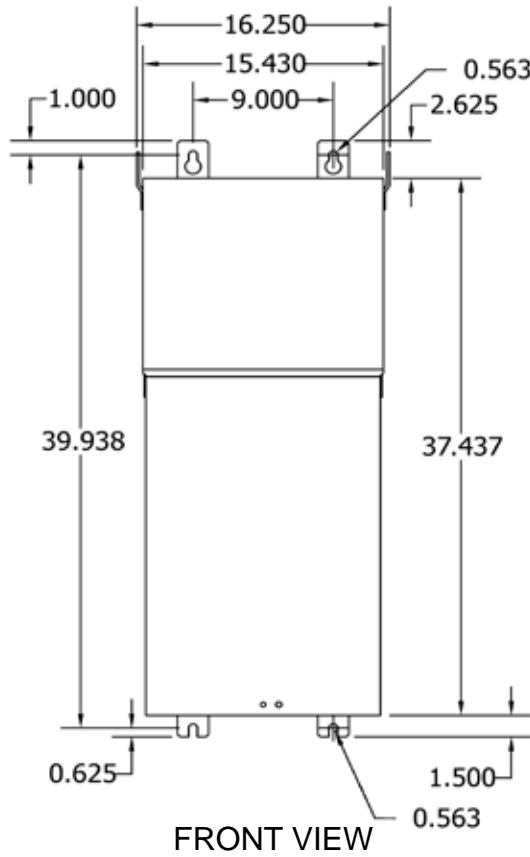

GENERAL
INFORMATION



GENERAL INFORMATION

ACCESSORIES (for transformers listed in sections 3, 4, 7 and 11)

ENCLOSURE MOUNTING KITS

If wall and/or ceiling mounting is desired for a transformer, optional mounting kits can be ordered separately. These mounting kits are NOT available for all enclosure case styles. Therefore, it is important that you confirm your enclosure case style, then use the selection table to the right to determine if A) a mounting kit is available and B) determine the correct HPS "Mounting Kit" part number that you must order. One kit is required for each transformer.

Note: Some of the mounting kits can be used for both wall and ceiling mount, while others are for wall mounting only. The table indicates which mounting methods are available for each kit. The NW2 wall/ceiling mounting kit also includes a drip plate.

The NW2 wall/ceiling mounting kit is only designed for units up to 750 pounds (341 kg) maximum.

Enclosure Case Style	Wall Mount Available	Ceiling Mount Available	HPS Mounting Kit P/N
N1	No	No	N/A
N2	No	No	N/A
NH3	Yes	Yes	NW2
NH4	No	No	N/A
NH5	Yes	Yes	NH5DP
NH6	Yes	Yes	NH6DP
NJ Series	No	No	N/A

NW2 WALL/CEILING MOUNTING KITS

The following drawings detail the wall and ceiling mounting dimensions required and method by which the NW2 kits are installed on the NH3 enclosures.

NW2 WALL MOUNT - MOUNTING DIMENSIONS

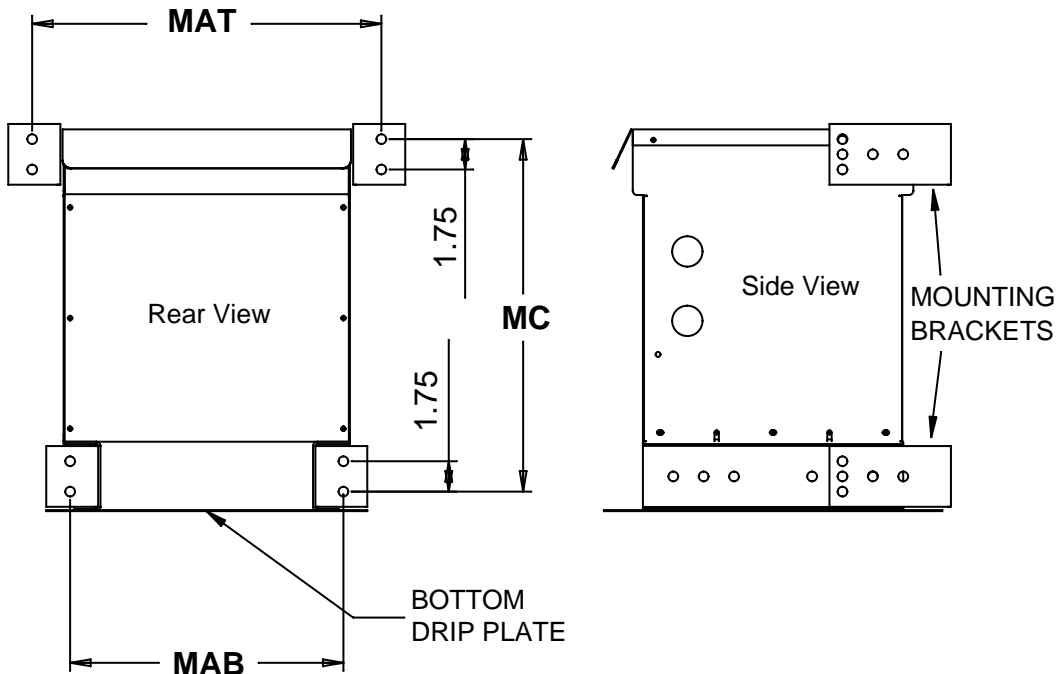

Wall Mounting Dimensions				
Part No.	Enclosure	MAT	MAB	MC
NW2	NH3	29.375	23.50	36.50

NOTE: Please refer to enclosure dimensional drawings on page 260 for more detailed dimensional information.

GENERAL INFORMATION



GENERAL INFORMATION

ACCESSORIES (for transformers listed in sections 3, 4, 7 and 11)

NW2 CEILING MOUNT - MOUNTING DIMENSIONS

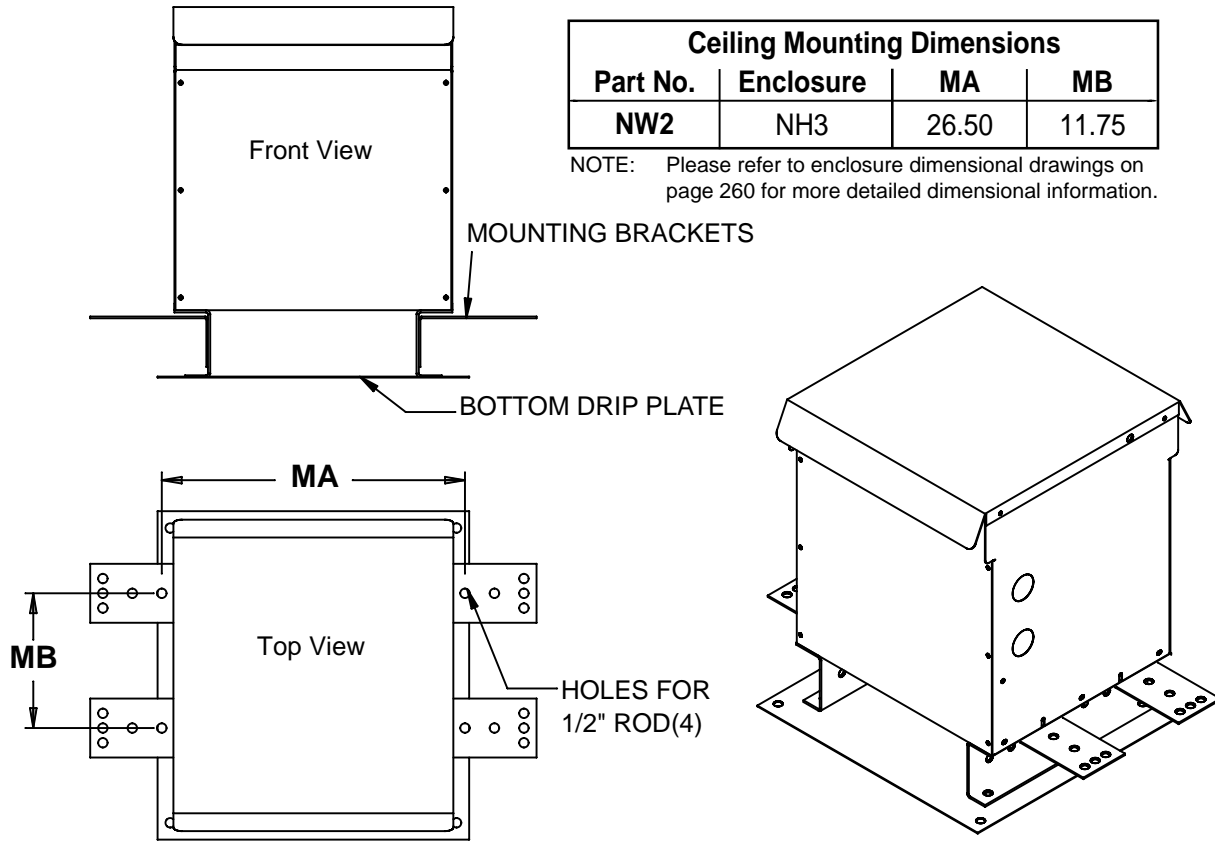

NH5DP & NH6DP WALL/CEILING MOUNTING KITS

The NH5 and NH6 enclosures are designed with integral wall mounting capabilities. However, when you wall mount them, you must also install the bottom drip plate as shown below. The "MB" dimensions listed in the table below indicate the location for the wall mounting hardware.

For ceiling mounting of the NH5 and NH6, refer to the "MA" dimensions listed in the table below and hang the enclosure using appropriate sized ceiling hanger rods. However, you must be sure to install the bottom drip plate to the bottom of the enclosure, then bring the hanger rod down through both the enclosure bottom mounting holes and through the drip plate mounting holes and install mounting hardware.

NOTE: Do not ceiling mount either the NH5 or NH6 enclosures without installing the bottom drip plate. All mounting hardware should be rated Grade 8 or higher.

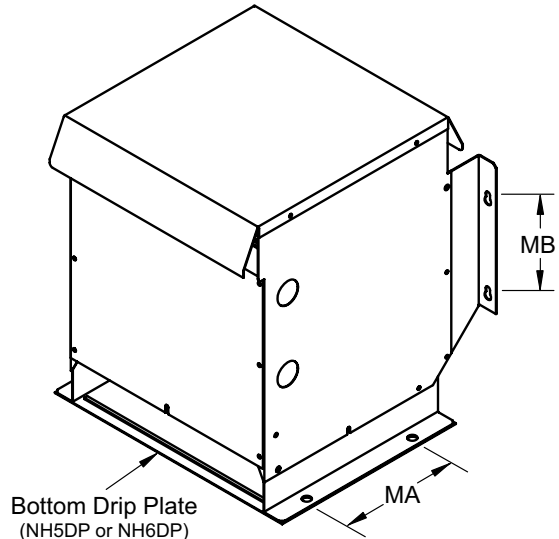

Mounting Kit P/N	Enclosure Style	MA Dimension	MB Dimension
NH5DP	NH5	9.00	7.00
NH6DP	NH6	9.00	8.00

NOTE: Please refer to enclosure dimensional drawings on page 260 for more detailed dimensional information.

GENERAL INFORMATION

ACCESSORIES (for transformers listed in sections 3, 4, 7 and 11)

ANTI-VIBRATION PAD AND VIBRATION ISOLATOR KITS

All standard transformers come with installed internal vibration absorbing pads to minimize noise during operation. Optional external “anti-vibration” pad and “vibration isolator” (for higher noise dampening) kits can be used to reduce operating noise even further. All are resistant to industrial contaminants like oils, acids and alkalis.

ANTI-VIBRATION PAD KITS

Part No.	Case Style	Description
P1	NH Series	Set of four (4) rubber anti-vibration pads which replace the standard steel enclosure washers.
P2	NJ Series	

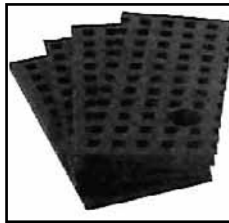

All Anti-Vibration Pad kits and Vibration Isolator kits contain a set of four (4) pads or isolators. Therefore only one kit is required per transformer.

VIBRATION ISOLATOR KITS

Part No.	Transformer Weight (Lb)	Description
NMP1	Up to 340 lbs	Set of four (4) molded neoprene and steel plate assemblies that virtually eliminate vibration noise between the transformer and the mounting surface.
NMP2	341 to 680 lbs	
NMP3	681 to 1040 lbs	
NMP4	1041 to 1740 lbs	
NMP5	1741 to 2330 lbs	
NMP6	2331 to 3450 lbs	
NMP7	3451 to 4690 lbs	



ACCESSORIES (for transformers listed in sections 8 and 10)

NQTW1 and NQTW2 Wall Mounting Kits

The **NQTW1** and **NQTW2** wall mounting kits are specifically designed for HPS commercial or industrial encapsulated (potted) distribution transformer units up to a maximum of 45kVA or 800 pounds (363 kg). These mounting kits are designed for encapsulated (potted) units only, no drip plate is included/required. Please contact HPS customer service if you have any questions.

Note: Always measure and secure mounting brackets to the wall surface first, then lift the transformer (using appropriate lifting equipment) onto the brackets and attach using minimum Grade 8 hardware.

Enclosure Case Style	Mounting Type	Wall Mounting Kit Part Number
NQ0-NQ8	Wall	Included
NQS10	Wall or Floor	NQTW2
NQT3-NQT6	Wall	Included
NQT7-NQT8	Wall or Floor	NQTW1
NQT9A	Floor	N/A
NQT9*	Wall or Floor	NQTW2

*Applies to HPS Fortress line only.

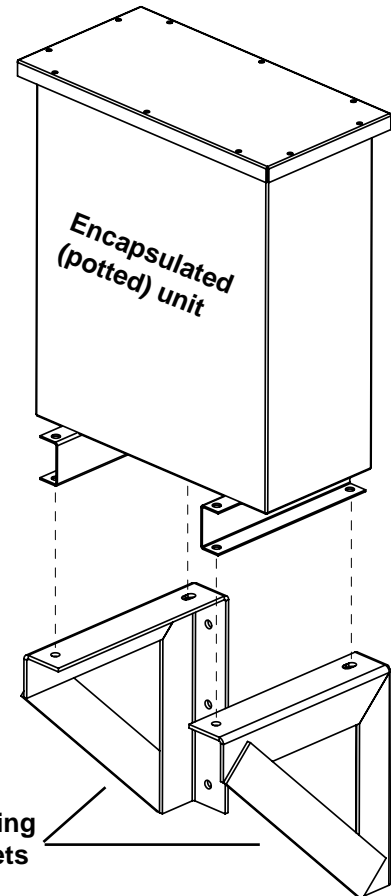

GENERAL INFORMATION



GENERAL INFORMATION

ACCESSORIES (for transformers listed in sections 8 and 10)

NQT ENCLOSURE SERIES NEMA 4/12 GASKET KITS

The following options and accessories offered are available on all standard and custom three phase HPS Titan® industrial encapsulated distribution transformers for harsh environments and hazardous locations (see section 8), HPS Fortress™ commercial encapsulated distribution transformers (see section 8) and encapsulated autotransformers (see section 10).

Optional NEMA 4/12 Gasket Kits

Standard NEMA 3R rated NQT enclosures can easily be converted to a NEMA 4 or 12 rating by ordering and installing the appropriate gasket kit as listed in the table below.

<u>Enclosure Style</u>	<u>Gasket Kit P/N</u>	<u>Enclosure Style</u>	<u>Gasket Kit P/N</u>
NQT2	NQT2GK	NQT8	NQT8GK
NQT3	NQT3GK	NQT9	NQT9GK
NQT4	NQT4GK	NQT9A	NQT9AGK
NQT5	NQT5GK	NQT10	NQT10GK
NQT6	NQT6GK	NQT11	NQT11GK
NQT7	NQT7GK		

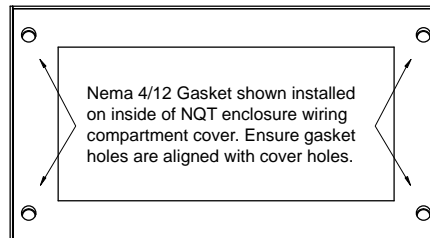
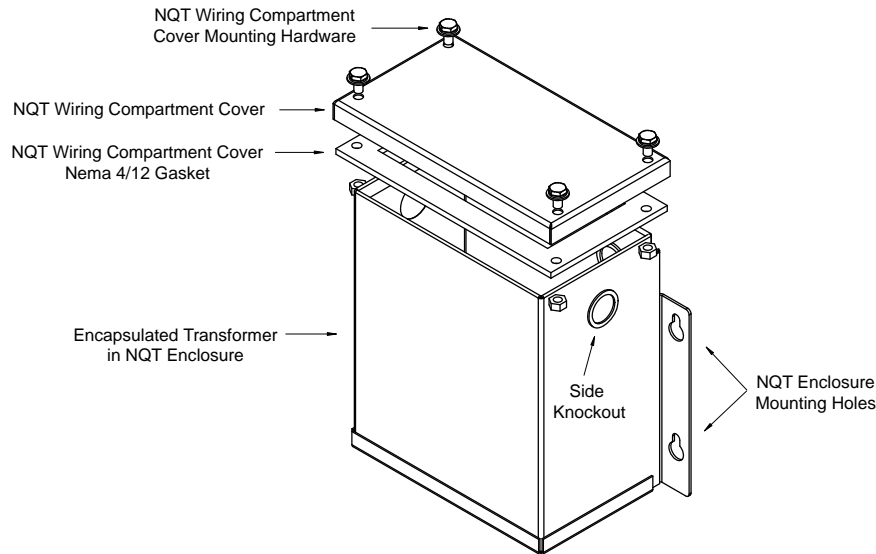

Optional Stainless Steel Enclosures

Optional NEMA 4 and 12 rated stainless steel enclosures for encapsulated transformers are identical to the standard steel enclosure designs but are designed using either type 304 or 316 stainless steel in accordance with ANSI, NEMA, UL and ABS requirements for indoor, outdoor and marine duty applications.

GENERAL INFORMATION

TERMINATION DETAILS - NEMA 3R

The following termination details are for standard 150°C temperature rise HPS Sentinel (section 7), HPS SuperSentinel (section 7) and general purpose medium voltage transformer (section 11) units only.

SINGLE PHASE, ALUMINUM AND COPPER TERMINATION - LUGS OR PADS

kVA	VOLTAGE											
	120	120/240	208	240	277	347	380	416	480	600	2400	4160
0.25	Leads	Leads	Leads	Leads	Leads	Leads	Leads	Leads	Leads	Leads	-	-
0.5	Leads	Leads	Leads	Leads	Leads	Leads	Leads	Leads	Leads	Leads	-	-
0.75	Leads	Leads	Leads	Leads	Leads	Leads	Leads	Leads	Leads	Leads	-	-
1	Leads	Leads	Leads	Leads	Leads	Leads	Leads	Leads	Leads	Leads	-	-
1.5	Leads	Leads	Leads	Leads	Leads	Leads	Leads	Leads	Leads	Leads	-	-
2	Leads	Leads	Leads	Leads	Leads	Leads	Leads	Leads	Leads	Leads	-	-
3	Leads	Leads	Leads	Leads	Leads	Leads	Leads	Leads	Leads	Leads	-	-
5	Leads	Leads	Leads	Leads	Leads	Leads	Leads	Leads	Leads	Leads	-	-
7.5	Lugs	Lugs	Lugs	Lugs	Lugs	Lugs	Lugs	Lugs	Lugs	Lugs	-	-
10	Lugs	Lugs	Lugs	Lugs	Lugs	Lugs	Lugs	Lugs	Lugs	Lugs	-	-
15	Lugs	Lugs	Lugs	Lugs	Lugs	Lugs	Lugs	Lugs	Lugs	Lugs	Dia. 1A	Dia. 1A
25	Lugs	Lugs	Lugs	Lugs	Lugs	Lugs	Lugs	Lugs	Lugs	Lugs	Dia. 1A	Dia. 1A
37.5	Dia. 2	Lugs	Lugs	Lugs	Lugs	Lugs	Lugs	Lugs	Lugs	Lugs	Dia. 1A	Dia. 1A
50	Dia. 2	Lugs	Lugs	Lugs	Lugs	Lugs	Lugs	Lugs	Lugs	Lugs	Dia. 1A	Dia. 1A
75	Dia. 3	Dia. 2	Dia. 2	Dia. 2	Lugs	Lugs	Lugs	Lugs	Lugs	Lugs	Dia. 1A	Dia. 1A
100	Dia. 3	Dia. 2	Dia. 2	Dia. 2	Dia. 2	Dia. 2	Lugs	Lugs	Lugs	Lugs	Dia. 1A	Dia. 1A
150	Dia. 3	Dia. 3	Dia. 3	Dia. 3	Dia. 2	Dia. 2	Dia. 2	Dia. 2	Dia. 2	Lugs	Dia. 1A	Dia. 1A
167	Dia. 3	Dia. 3	Dia. 3	Dia. 3	Dia. 3	Dia. 2	Dia. 2	Dia. 2	Dia. 2	Dia. 2	Dia. 1A	Dia. 1A

THREE PHASE, ALUMINUM AND COPPER TERMINATION - LUGS OR PADS

kVA	VOLTAGE									
	208	230	240	277	380	416	480	600	2400	4160
2	Leads	Leads	Leads	Leads	Leads	Leads	Leads	Leads	-	-
3	Leads	Leads	Leads	Leads	Leads	Leads	Leads	Leads	-	-
6	Leads	Leads	Leads	Leads	Leads	Leads	Leads	Leads	-	-
9	Lugs	Lugs	Lugs	Lugs	Lugs	Lugs	Lugs	Lugs	-	-
15	Lugs	Lugs	Lugs	Lugs	Lugs	Lugs	Lugs	Lugs	Dia. 1A	Dia. 1A
30	Lugs	Lugs	Lugs	Lugs	Lugs	Lugs	Lugs	Lugs	Dia. 1A	Dia. 1A
45	Lugs	Lugs	Lugs	Lugs	Lugs	Lugs	Lugs	Lugs	Dia. 1A	Dia. 1A
75	Lugs	Lugs	Lugs	Lugs	Lugs	Lugs	Lugs	Lugs	Dia. 1A	Dia. 1A
112.5	Lugs**	Dia. 1B	Lugs	Lugs	Lugs	Lugs	Lugs	Lugs	Dia. 1A	Dia. 1A
150	Dia. 1B	Dia. 1B	Dia. 1B	Dia. 1B	Lugs	Lugs	Lugs	Lugs	Dia. 1A	Dia. 1A
225	Dia. 2	Dia. 1B	Dia. 1B	Dia. 1B	Dia. 1B	Dia. 1B	Lugs	Lugs	Dia. 1A	Dia. 1A
300	Dia. 2	Dia. 2	Dia. 2	Dia. 2	Dia. 1B	Dia. 1B	Dia. 1B	Dia. 1B	Dia. 1A	Dia. 1A
500	Dia. 3	Dia. 3	Dia. 3	Dia. 3	Dia. 3	Dia. 2	Dia. 2	Dia. 1B	Dia. 1A	Dia. 1A
600	Dia. 3	Dia. 3	Dia. 3	Dia. 3	Dia. 3	Dia. 2	Dia. 2	Dia. 1B	Dia. 1A	Dia. 1A
750	Dia. 3	Dia. 3	Dia. 3	Dia. 3	Dia. 3	Dia. 3	Dia. 3	Dia. 2	Dia. 1B	Dia. 1A

** Lugs only supplied standard on 600V primary to 208Y/120V secondary units.(excluding K-Factor transformers)
All other voltages supplied standard with Diagram 1B pads.

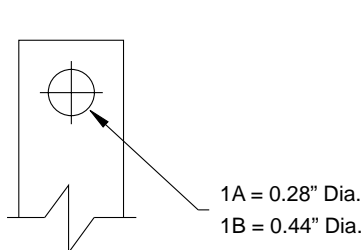

DIAGRAM 1

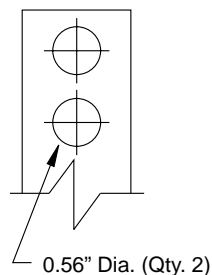

DIAGRAM 2

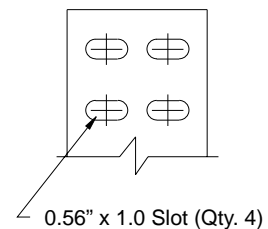

DIAGRAM 3



GENERAL INFORMATION

ELECTRICAL SCHEMATICS AND CONNECTION DIAGRAMS

SCD 1

SCHEMATIC				CONNECTIONS			
				Primary Volts		Connect lines to	Inter-connect
				240	480	416	H1, H4
		120	240	208	H1, H4	H1-H3, H2-H4	
				Secondary Volts		Connect lines to	Inter-connect
		24	32	48	240	X1, X4	X2-X3
		12/24	16/32	24/48	120/240	X1, X2, X4	X2-X3
		12	16	24	120	X1, X2	X2-X4, X1-X3

SCD 2

SCHEMATIC				CONNECTIONS						
				Primary Volts		Connect lines to	Inter-connect			
				504	440	437	218	291	277	440
		492		426	213	284		H1, H2	2-3	
		480	416	416	208	277	240	416	H1, H2	3-4
		468		406	203	270		H1, H2	4-5	
		456	400	395	198	263	208	400	H1, H2	5-6
		444		385	192	256		H1, H2	6-7	
		432	380	374	187	249	120	380	H1, H2	7-8
			220					H1, H2	H1-2, H2-1	
		240	208	208				H1, H2	H1-4, H2-3	
		228	200	198				H1, H2	H1-6, H2-5	
		216	190	187				H1, H2	H1-8, H2-7	
				Secondary Volts		Connect lines to	Inter-connect			
			240			X1, X4	X2- X3			
			120			X1, X2	X2-X4, X1-X3			
			120/240			X1, X2, X4	X2-X3			

SCD 3

SCHEMATIC				CONNECTIONS			
				Primary Volts		Connect lines to	Inter-connect
				630		H1, H2, H3	1-H1, 1-H2, 1-H3
		615		H1, H2, H3	2-H1, 2-H2, 2-H3		
		600		H1, H2, H3	3-H1, 3-H2, 3-H3		
		585		H1, H2, H3	4-H1, 4-H2, 4-H3		
		570		H1, H2, H3	5-H1, 5-H2, 5-H3		
		480		H1, H2, H3	6-H1, 6-H2, 6-H3		
		456		H1, H2, H3	7-H1, 7-H2, 7-H3		
		432		H1, H2, H3	8-H1, 8-H2, 8-H3		
				Secondary Volts		Connect lines to	Inter-connect
		208	480		X1, X2, X3	-	
		120	120		X1, X0	-	
					X2, X0	-	
					X3, X0	-	

GENERAL INFORMATION

ELECTRICAL SCHEMATICS AND CONNECTION DIAGRAMS

SCD 4

SCHEMATIC	CONNECTIONS				
	Primary Volts	Connect lines to	Inter-connect		
	208 277 347 380 416 600 2400 3300 4160 4800 6600 7200	H1, H2	---		
	Secondary Volts	Connect lines to	Inter-connect		
	240	24	X1, X4	X2-X3	
	120/240	12/24	X1, X2, X4	X2-X3	
	120	12	X1, X2	X2-X4, X1-X3	

SCD 5

SCHEMATIC	CONNECTIONS			
	Primary Volts	Connect lines to	Inter-connect	
	120 208 240 277 380 416 480 600	H1, H2	1-2	
	114 198 228 263 361 395 456 570	H1, H2	2-3	
	108 188 216 249 347 374 432 540	H1, H2	3-4	
	Secondary Volts	Connect lines to	Inter-connect	
	240	X1, X4	X2-X3	
	120/240	X1, X2, X4	X2-X3	
	120	X1, X2	X2-X4, X1-X3	

SCD 6

SCHEMATIC	CONNECTIONS			
	Primary Volts	Connect lines to	Inter-connect	
	218 277 291 437 504 630 2520 4368	H1, H2	1-2	
	213 - 284 426 492 615 2460 4264	H1, H2	2-3	
	208 240 277 416 480 600 2400 4160	H1, H2	3-4	
	203 - 270 406 468 585 2340 4056	H1, H2	4-5	
	198 208 263 395 456 570 2280 3952	H1, H2	5-6	
	Secondary Volts	Connect lines to	Inter-connect	
	240	X1, X4	X2-X3	
	120/240	X1, X2, X4	X2-X3	
	120	X1, X2	X2-X4, X1-X3	

SCD 7

SCHEMATIC	CONNECTIONS			
	Primary Volts	Connect lines to	Inter-connect	
	208 218 242 252 437 480 483 504 604 630	H1, H2, H3	1	
	198 208 230 240 416 456 460 480 575 600	H1, H2, H3	2	
	187 198 219 228 395 432 437 456 546 570	H1, H2, H3	3	
	Secondary Volts	Connect lines to	Inter-connect	
	208 230 240 380 416 460 480 600	X1, X2, X3		
	120 133 139 220 240 265 277 347	X1, X0 X2, X0 X3, X0		

GENERAL INFORMATION



GENERAL INFORMATION

ELECTRICAL SCHEMATICS AND CONNECTION DIAGRAMS

SCD 8

SCHEMATIC	CONNECTIONS			
	Primary Volts		Connect lines to	Inter-connect
	218 242 252 437 483 504 604 630 2520 4368	H1, H2, H3	1-2	
	208 230 240 416 460 480 575 600 2400 4160	H1, H2, H3	2-3	
198 219 228 395 437 456 546 570 2280 3952	H1, H2, H3	3-4		
Secondary Volts		Connect lines to		
208 230 240 380 416 460 480 600	X1, X2, X3			
120 133 139 220 240 265 277 347	X1, X0	X2, X0	X3, X0	

SCD 9

SCHEMATIC	CONNECTIONS			
	Primary Volts		Connect lines to	Inter-connect
	218 242 252 437 483 504 604 630	H1, H2, H3	1	
	213 236 246 426 472 492 589 615	H1, H2, H3	2	
208 230 240 416 460 480 575 600	H1, H2, H3	3		
203 224 234 406 449 468 561 585	H1, H2, H3	4		
198 219 228 395 437 456 546 570	H1, H2, H3	5		
Secondary Volts		Connect lines to		Inter-connect
208 380 416 480 600	X1, X2, X3		-	
120 220 240 277 347	X1, X0	-		
	X2, X0	-		
	X3, X0	-		

SCD 10

SCHEMATIC	CONNECTIONS			
	Primary Volts		Connect lines to	Inter-connect
	218 242 252 437 483 504 604 630 2520 4368	H1, H2, H3	1-2	
	213 236 246 426 472 492 589 615 2460 4264	H1, H2, H3	2-3	
208 230 240 416 460 480 575 600 2400 4160	H1, H2, H3	3-4		
203 224 234 406 449 468 561 585 2340 4056	H1, H2, H3	4-5		
198 219 228 395 437 456 546 570 2280 3952	H1, H2, H3	5-6		
Secondary Volts		Connect lines to		Inter-connect
208 380 416 480 600	X1, X2, X3		-	
120 220 240 277 347	X1, X0	-		
	X2, X0	-		
	X3, X0	-		

GENERAL INFORMATION

ELECTRICAL SCHEMATICS AND CONNECTION DIAGRAMS

SCD 11

SCHEMATIC	CONNECTIONS		
	Primary Volts	Connect lines to	Inter-connect
	630	H1, H2, H3	1-H1, 1-H2, 1-H3
	615	H1, H2, H3	2-H1, 2-H2, 2-H3
	600	H1, H2, H3	3-H1, 3-H2, 3-H3
	585	H1, H2, H3	4-H1, 4-H2, 4-H3
	570	H1, H2, H3	5-H1, 5-H2, 5-H3
	504	H1, H2, H3	6-H1, 6-H2, 6-H3
	492	H1, H2, H3	7-H1, 7-H2, 7-H3
	480	H1, H2, H3	8-H1, 8-H2, 8-H3
	468	H1, H2, H3	9-H1, 9-H2, 9-H3
	456	H1, H2, H3	10-H1, 10-H2, 10-H3
	Secondary Volts	Connect lines to	Inter-connect
	208 480	X1, X2, X3	-
	120 277	X1, X0	-
		X2, X0	-
	X3, X0	-	

SCD 12

SCHEMATIC	CONNECTIONS		
	Primary Volts	Connect lines to	Inter-connect
	480 600	H1, H2, H3	1-2
	456 570	H1, H2, H3	2-3
	432 540	H1, H2, H3	3-4
	Secondary Volts	Connect lines to	Inter-connect
240	X1, X2, X3	-	

SCD 13

SCHEMATIC	CONNECTIONS		
	Primary Volts	Connect lines to	Inter-connect
	480 600	H1, H2, H3	1-2
	456 570	H1, H2, H3	2-3
	432 540	H1, H2, H3	3-4
	Secondary Volts	Connect lines to	Inter-connect
	240	X1, X2, X3	-
120	X1, X6	-	
	X3, X6	-	

SCD 14

SCHEMATIC	CONNECTIONS		
	Connect to	Step Down	Step Up
	Lines from Supply	H1, H2, H3	X1, X2, X3
	Lines to Load	X1, X2, X3	H1, H2, H3

GENERAL INFORMATION



GENERAL INFORMATION

ELECTRICAL SCHEMATICS AND CONNECTION DIAGRAMS

SCD 15

SCHEMATIC	CONNECTIONS		
	Connect to	Step Down	Step Up
	Lines from Supply	H1, H2, H3	X1, X2, X3
	Lines to Load	X1, X2, X3	H1, H2, H3

SCD 16

SCHEMATIC	CONNECTIONS		
	Primary Volts	Connect lines to	Inter-connect
	504 630	H1, H2, H3	1
	492 615	H1, H2, H3	2
	480 600	H1, H2, H3	3
	468 585	H1, H2, H3	4
	456 570	H1, H2, H3	5
	Secondary Volts	Connect lines to	Inter-connect
	240	X1, X2, X3	

SCD 17

SCHEMATIC	CONNECTIONS		
	Primary Volts	Connect lines to	Inter-connect
	504	H1, H4	1-H2, 2-H3, H2-H3
	492	H1, H4	3-H2, 2-H3, H2-H3
	480	H1, H4	3-H2, 4-H3, H2-H3
	468	H1, H4	5-H2, 4-H3, H2-H3
	456	H1, H4	5-H2, 6-H3, H2-H3
	444	H1, H4	7-H2, 6-H3, H2-H3
	432	H1, H4	7-H2, 8-H3, H2-H3
	252	H1, H4	1-H2, 2-H3, H1-H3, H2-H4
	240	H1, H4	3-H2, 4-H3, H1-H3, H2-H4
	228	H1, H4	5-H2, 6-H3, H1-H3, H2-H4
	216	H1, H4	7-H2, 8-H3, H1-H3, H2-H4
		Secondary Volts	Connect lines to
	240	X1, X4	X2- X3
	120	X1, X2	X2-X4, X1-X3
	120/240	X1, X2, X4	X2-X3

SCD 18

SCHEMATIC	CONNECTIONS		
	Primary Volts	Connect lines to	Inter-connect
	218 252 277 291 437 504 630	H1, H4	-
	208 240 240 277 416 480 600	H1, H3	-
	198 228 208 263 395 456 570	H1, H2	-
	Secondary Volts	Connect lines to	Inter-connect
	240	X1, X4	X2-X3
	120	X1, X2	X2-X4, X1-X3
	120/240	X1, X2, X4	X2-X3

GENERAL INFORMATION

ELECTRICAL SCHEMATICS AND CONNECTION DIAGRAMS

SCD 19

SCHEMATIC		CONNECTIONS		
		Primary Volts	Connect lines to	Inter-connect
		218 504 630 213 492 615 208 480 600 203 468 585 198 456 570 193 444 556 188 432 542	H1, H2, H3 H1, H2, H3 H1, H2, H3 H1, H2, H3 H1, H2, H3 H1, H2, H3 H1, H2, H3	1-H1, 1-H2, 1-H3 2-H1, 2-H2, 2-H3 3-H1, 3-H2, 3-H3 4-H1, 4-H2, 4-H3 5-H1, 5-H2, 5-H3 6-H1, 6-H2, 6-H3 7-H1, 7-H2, 7-H3
		Secondary Volts	Connect lines to	Inter-connect
		208 480 120 277	X1, X2, X3 X1,X0 X2,X0 X3,X0	- -

SCD 20

SCHEMATIC		CONNECTIONS		
		Primary Volts	Connect lines to	Inter-connect
		218 504 630 213 492 600 208 480 570 203 468 570 198 456 504 193 444 480 188 432 456	H1, H2, H3 H1, H2, H3 H1, H2, H3 H1, H2, H3 H1, H2, H3 H1, H2, H3 H1, H2, H3	1-2 2-3 3-4 4-5 5-6 6-7 7-8
		Secondary Volts	Connect lines to	Inter-connect
		208 120	X1, X2, X3 X1,X0 X2,X0 X3,X0	- -

SCD 21

SCHEMATIC		CONNECTIONS		
		Primary Volts	Connect lines to	Inter-connect
		504 492 480 468 456 444 432	H1, H2, H3 H1, H2, H3 H1, H2, H3 H1, H2, H3 H1, H2, H3 H1, H2, H3 H1, H2, H3	1-H1, 1-H2, 1-H3 2-H1, 2-H2, 2-H3 3-H1, 3-H2, 3-H3 4-H1, 4-H2, 4-H3 5-H1, 5-H2, 5-H3 6-H1, 6-H2, 6-H3 7-H1, 7-H2, 7-H3
		Secondary Volts	Connect lines to	Inter-connect
		240 120	X1, X2, X3 X1, X6 X3, X6	- - -

SCD 22

SCHEMATIC		CONNECTIONS		
		Primary Volts	Connect lines to	Inter-connect
		504 492 480 468 456 444 432	H1, H2, H3 H1, H2, H3 H1, H2, H3 H1, H2, H3 H1, H2, H3 H1, H2, H3 H1, H2, H3	1-2 2-3 3-4 4-5 5-6 6-7 7-8
		Secondary Volts	Connect lines to	Inter-connect
		240 120	X1, X2, X3 X1, X6 X3, X6	- - -

GENERAL INFORMATION



GENERAL INFORMATION

ELECTRICAL SCHEMATICS AND CONNECTION DIAGRAMS

SCD 23

SCHEMATIC		CONNECTIONS			
		Primary Volts		Connect lines to	Inter-connect
		208	240	X1, X2, X3	1-2
		198	228	X1, X2, X3	2-3
		Secondary Volts		Connect lines to	
230	260	460	480	H1, H2, H3	
133	139	265	277	H1, H0 H2, H0 H3, H0	

SCD 24

SCHEMATIC		CONNECTIONS		
		Connect to	Step Down	Step Up
		Lines from Supply	H1, H2, H3	X1, X2, X3
		Lines to Load	X1, X2, X3	H1, H2, H3

SCD 25

SCHEMATIC		CONNECTIONS						
		Primary Volts		Connect lines to	Inter-connect			
		208	240	416	480	600	H1, H2, H3	1-2
		198	228	395	456	570	H1, H2, H3	2-3
		Secondary Volts		Connect lines to		Inter-connect		
208	380	416	480	600	X1, X2, X3		-	
120	220	240	277	347	X1, X0 X2, X0 X3, X0		-	

SCD 26

SCHEMATIC		CONNECTIONS						
		Primary Volts		Connect lines to	Inter-connect			
		218	252	X1, X2, X3		1		
		213	246	X1, X2, X3		2		
		Secondary Volts		Connect lines to		Inter-connect		
208	240	X1, X2, X3		3				
203	234	X1, X2, X3		4				
198	228	X1, X2, X3		5				
460	480	600	H1, H2, H3		-			
265	277	347	H1, H0 H2, H0 H3, H0		-			

SCD 27

SCHEMATIC		CONNECTIONS						
		Primary Volts		Connect lines to	Inter-connect			
		630	H1, H2, H3		1-2			
		600	H1, H2, H3		2-3			
		Secondary Volts		Connect lines to		Inter-connect		
570	H1, H2, H3		3-4					
240	X1, X2, X3		-					

GENERAL INFORMATION

ELECTRICAL SCHEMATICS AND CONNECTION DIAGRAMS

SCD 28

SCHEMATIC	CONNECTIONS		
	Primary Volts	Connect lines to	Inter-connect
	480 (60Hz)	H1, H10	H5-H6
	440	H1, H10	H5-H6
	416	H1, H9	H4-H6
	400	H1, H8	H3-H6
	380	H1, H7	H2-H6
	240 (60 Hz)	H1, H10	H1-H6, H5-H10
	220	H1, H10	H1-H6, H5-H10
	208	H1, H9	H1-H6, H4-H9
	200	H1, H8	H1-H6, H3-H8
	190	H1, H7	H1-H6, H2-H7
	Secondary Volts	Connect lines to	Inter-connect
	240	X1, X4	X2-X3
120/240	X1, X2, X4	X2-X3	
120	X1, X4	X2-X4, X1-X3	

SCD 29

SCHEMATIC	CONNECTIONS			
	Primary Volts	Connect lines to	Inter-connect	
	630	504	H1, H2, H3	1-2
	615	492	H1, H2, H3	2-3
	600	480	H1, H2, H3	3-4
	585	468	H1, H2, H3	4-5
	570	456	H1, H2, H3	5-6
	Secondary Volts	Connect lines to	Inter-connect	
240	X1, X2, X3			

SCD 30

SCHEMATIC	CONNECTIONS		
	Primary Volts	Connect lines to	Inter-connect
	440	H1, H4	1-H2, 2-H3, H2-H3
	416	H1, H4	3-H2, 4-H3, H2-H3
	400	H1, H4	5-H2, 6-H3, H2-H3
	380	H1, H4	7-H2, 8-H3, H2-H3
	220	H1, H4	1-H2, 2-H3, H1-H3, H2-H4
	208	H1, H4	3-H2, 4-H3, H1-H3, H2-H4
	200	H1, H4	5-H2, 6-H3, H1-H3, H2-H4
	190	H1, H4	7-H2, 8-H3, H1-H3, H2-H4
	Secondary Volts	Connect lines to	Inter-connect
	240	X1, X4	X2- X3
120	X1, X2	X2-X4, X1-X3	
120/240	X1, X2, X4	X2-X3	

GENERAL INFORMATION



GENERAL INFORMATION

ELECTRICAL SCHEMATICS AND CONNECTION DIAGRAMS

SCD 31

SCHEMATIC		CONNECTIONS				
		Primary Volts		Connect lines to	Inter-connect	
		218	291	437	504	630
213	284	426	492	615	H1, H5	-
208	277	416	480	600	H2, H5	-
203	270	406	468	585	H2, H4	-
198	263	395	456	570	H3, H4	-
		Secondary Volts		Connect lines to	Inter-connect	
		240		X1, X4	X2-X3	
		120/240		X1, X2, X4	X2-X3	
		120		X1, X2	X2-X4, X1-X3	

SCD 32

SCHEMATIC		CONNECTIONS				
		Primary Volts		Connect lines to	Inter-connect	
		208	277	416	480	600
198	263	395	456	570	H1, H3	-
188	249	374	432	540	H2, H3	-
		Secondary Volts		Connect lines to	Inter-connect	
		240		X1, X4	X2-X3	
		120/240		X1, X2, X4	X2-X3	
		120		X1, X2	X2-X4, X1-X3	

SCD 33

SCHEMATIC		CONNECTIONS		
		Primary Volts		Inter-connect
		380	H1, H3	
347	H1, H2		-	
		Secondary Volts		Inter-connect
		240		X2-X3
		120/240		X2-X3
		120		X2-X4, X1-X3

SCD 34

SCHEMATIC		CONNECTIONS		
		Primary Volts		Inter-connect
		480	H1, H4	
456	H1, H4		2-H3, 3-H2, H2-H3	
432	H1, H4		3-H2, 4-H3, H2-H3	
240	H1, H4		1-H2, 2-H3, H1-H3, H2-H4	
216	H1, H4		3-H2, 4-H3, H1-H3, H2-H4	
		Secondary Volts		Inter-connect
		240		X2-X3
		120/240		X2-X3
		120		X2-X4, X1-X3

GENERAL INFORMATION

ELECTRICAL SCHEMATICS AND CONNECTION DIAGRAMS

SCD 35

SCHEMATIC	CONNECTIONS				
	Primary Volts	Connect lines to	Inter-connect		
	218*	504	630	H1, H2, H3	1-H1, 1-H2, 1-H3
	213*	492	615	H1, H2, H3	2-H1, 2-H2, 2-H3
	208*	480	600	H1, H2, H3	3-H1, 3-H2, 3-H3
	203*	468	585	H1, H2, H3	4-H1, 4-H2, 4-H3
	198*	456	570	H1, H2, H3	5-H1, 5-H2, 5-H3
	Secondary Volts			Connect lines to	Inter-connect
208	480	600	X1, X2, X3	-	
120	277	347	X1,X0 X2,X0 X3,X0	-	

* Standard 2-2.5% FCAN and 2-2.5% FCBN primary taps for 208V H2EM units only available up to 75 kVA. Please consult factory for standard taps on 208V primary units over 75 kVA.

SCD 36

SCHEMATIC	CONNECTIONS				
	Primary Volts	Connect lines to	Inter-connect		
	218*	504	630	H1, H2, H3	1-2
	213*	492	615	H1, H2, H3	2-3
	208*	480	600	H1, H2, H3	3-4
	203*	468	585	H1, H2, H3	4-5
	198*	456	570	H1, H2, H3	5-6
	Secondary Volts			Connect lines to	Inter-connect
208	480	600	X1, X2, X3	-	
120	277	347	Y1, Y2, Y3	-	
			X1, X0/Y0	-	
			X2, X0/Y0	-	
			X3, X0/Y0	-	
			Y1, X0/Y0	-	
			Y2, X0/Y0	-	
			Y3, X0/Y0	-	

* Standard 2-2.5% FCAN and 2-2.5% FCBN primary taps for 208V H2EM units only available up to 75 kVA. Please consult factory for standard taps on 208V primary units over 75 kVA.

SCD 37

SCHEMATIC	CONNECTIONS		
	Primary Volts	Connect lines to	Inter-connect
	480	H1, H2, H3	1
	456	H1, H2, H3	2
	432	H1, H2, H3	3
	Secondary Volts		
240	X1, X2, X3	-	

GENERAL INFORMATION

GENERAL INFORMATION

ELECTRICAL SCHEMATICS AND CONNECTION DIAGRAMS

SCD 38

SCHEMATIC	CONNECTIONS		
	Primary Volts	Connect lines to	Inter-connect
	504	H1, H2, H3	1
	492	H1, H2, H3	2
	480	H1, H2, H3	3
	468	H1, H2, H3	4
	456	H1, H2, H3	5
	444	H1, H2, H3	6
	432	H1, H2, H3	7
	Secondary Volts	Connect lines to	Inter-connect
	240	X1, X2, X3	-

SCD 39

SCHEMATIC	CONNECTIONS		
	Primary Volts	Connect lines to	Inter-connect
	218 291 437 504 630	H1, H2	1
	213 284 426 492 615	H1, H2	2
	208 277 416 480 600	H1, H2	3
	203 270 406 468 585	H1, H2	4
	198 263 395 456 570	H1, H2	5
		Secondary Volts	Connect lines to
	240	X1, X4	X2-X3
	120/240	X1, X2, X4	X2-X3
	120	X1, X2	X2-X4, X1-X3

SCD 40

SCHEMATIC	CONNECTIONS		
	Primary Volts	Connect lines to	Inter-connect
	208 240	X1, X2, X3	1
	198 228	X1, X2, X3	2
	188 216	X1, X2, X3	3
	Secondary Volts	Connect lines to	Inter-connect
	230 260 460 480	H1, H2, H3	
	133 139 265 277	H1, H0 H2, H0 H3, H0	

SCD 41

SCHEMATIC	CONNECTIONS		
	Primary Volts	Connect lines to	Inter-connect
	277	H1, H5	-
	240	H1, H4	-
	208	H1, H3	-
	120	H1, H2	-
	Secondary Volts	Connect lines to	Inter-connect
	240	X1, X4	X2-X3
	120/240	X1, X2, X4	X2-X3
	120	X1, X2	X2-X4, X1-X3

GENERAL INFORMATION

ELECTRICAL SCHEMATICS AND CONNECTION DIAGRAMS

SCD 42

SCHEMATIC	CONNECTIONS		
	Primary Volts	Connect lines to	Inter-connect
	480	H1, H3	-
	277	H1, H2	-
	Secondary Volts	Connect lines to	Inter-connect
277	X1, X3	-	
208	X1, X2	-	

SCD 43

SCHEMATIC	CONNECTIONS		
	Primary Volts	Connect lines to	Inter-connect
	480	H1, H2	1-2
	277	H1, H2	3-4
	Secondary Volts	Connect lines to	Inter-connect
277	X1, X2	X5-X6	
208	X1, X2	X3-X4	

SCD 44

SCHEMATIC	CONNECTIONS		
	Primary Volts	Connect lines to	Inter-connect
	380	H1, H2	1-2
	347	H1, H2	3-4
	Secondary Volts	Connect lines to	Inter-connect
	240	X1, X4	X2-X3
	120/240	X1, X2, X4	X2-X3
120	X1, X2	X2-X4, X1-X3	

SCD 45

SCHEMATIC	CONNECTIONS		
	Primary Volts	Connect lines to	Inter-connect
	630	H1, H2, H3	1
	615	H1, H2, H3	2
	600	H1, H2, H3	3
	585	H1, H2, H3	4
	570	H1, H2, H3	5
Secondary Volts	Connect lines to	Inter-connect	
240	X1, X2, X3	-	

GENERAL INFORMATION



GENERAL INFORMATION

ELECTRICAL SCHEMATICS AND CONNECTION DIAGRAMS

SCD 46

SCHEMATIC	CONNECTIONS		
	Primary Volts	Connect lines to	Inter-connect
	480 (60Hz)	H1, H2	1-2
	440	H1, H2	1-2
	416	H1, H2	3-4
	400	H1, H2	5-6
	380	H1, H2	7-8
	240 (60Hz)	H1, H2	H1-2, H2-1
	220	H1, H2	H1-2, H2-1
	208	H1, H2	H1-4, H2-3
	200	H1, H2	H1-6, H2-5
	190	H1, H2	H1-8, H2-7
	Secondary Volts	Connect lines to	Inter-connect
	240	X1, X4	X2- X3
120	X1, X2	X2-X4, X1-X3	
120/240	X1, X2, X4	X2-X3	

SCD 47

SCHEMATIC	CONNECTIONS		
	Primary Volts	Connect lines to	Inter-connect
	630	H1, H2, H3	1-H1, 1-H2, 1-H3
	615	H1, H2, H3	2-H1, 2-H2, 2-H3
	600	H1, H2, H3	3-H1, 3-H2, 3-H3
	585	H1, H2, H3	4-H1, 4-H2, 4-H3
	570	H1, H2, H3	5-H1, 5-H2, 5-H3
	480	H1, H2, H3	6-H1, 6-H2, 6-H3
	456	H1, H2, H3	7-H1, 7-H2, 7-H3
	432	H1, H2, H3	8-H1, 8-H2, 8-H3
	Secondary Volts	Connect lines to	Inter-connect
	480	X1, X2, X3	-
277	X1,X0 X2,X0 X3,X0	-	

SCD 48

SCHEMATIC	CONNECTIONS		
	Primary Volts	Connect lines to	Inter-connect
	347	H1, H2	H2-3 & 4
	380	H1, H2	H2-1 & 2
	Secondary Volts	Connect lines to	Inter-connect
	240	X1, X4	X2-X3
	120	X1, X2	X1-X3, X2-X3
	120/240	X1, X2, X4	X2-X3

GENERAL INFORMATION

ELECTRICAL SCHEMATICS AND CONNECTION DIAGRAMS

SCD 49

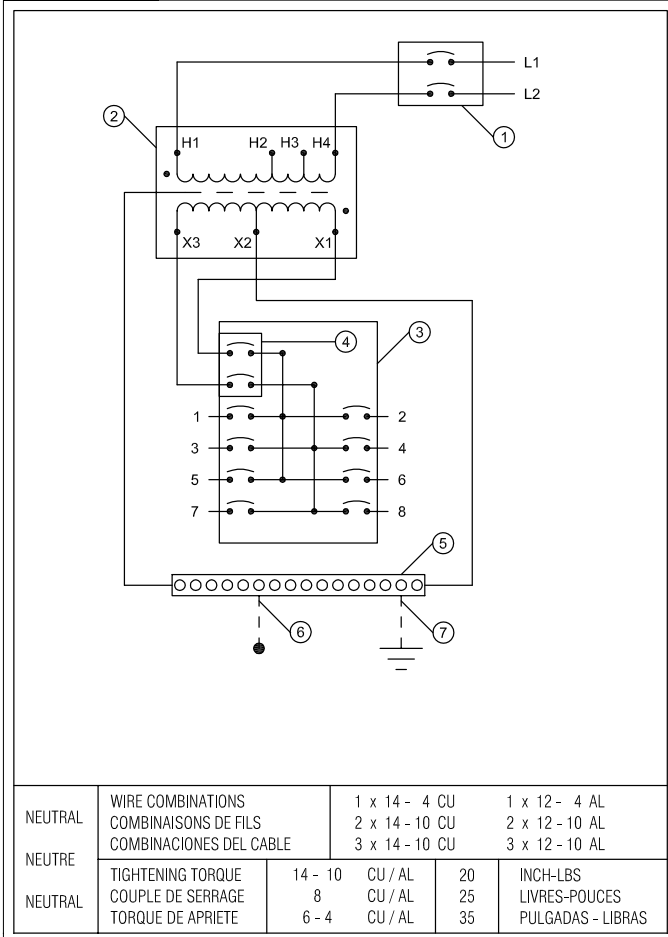

SCD 50

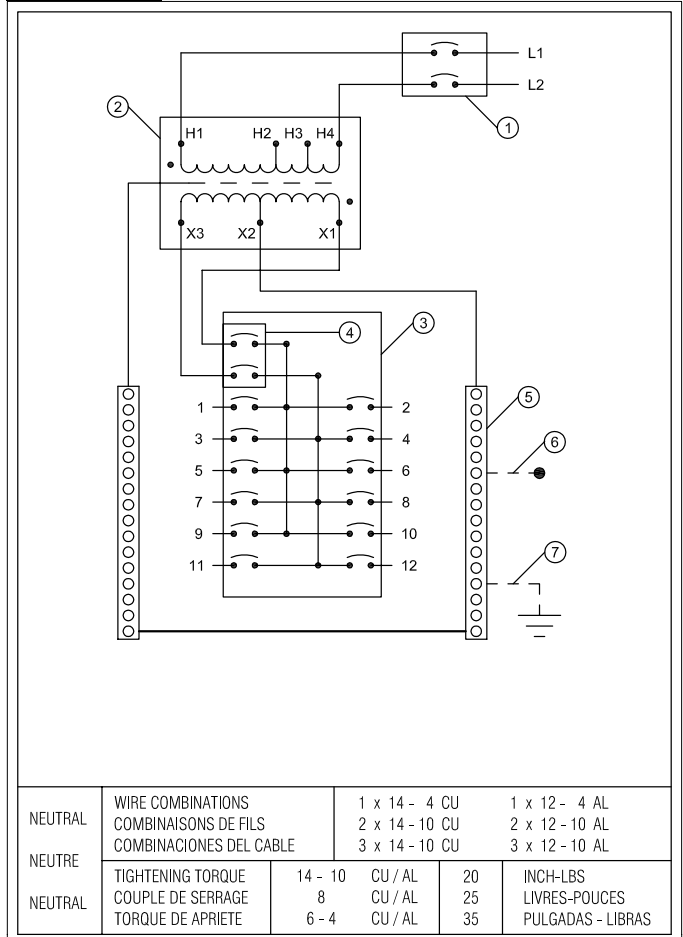

- 1 - Main Breaker
- 2 - Transformer
- 3 - Panel Board
- 4 - Panel Board Feed Breaker
- 5 - Neutral
- 6 - Bond When Required
- 7 - Ground When Required

- The maximum continuous load current not to exceed 100% of the transformer nominal current.
- The maximum continuous load current for the branch circuits not to exceed 80% of the ratings of the circuit breakers employed in other than motor circuits.
- Maximum short-circuit capacity 10,000 amps

GENERAL INFORMATION



GENERAL INFORMATION

ELECTRICAL SCHEMATICS AND CONNECTION DIAGRAMS

SCD 51

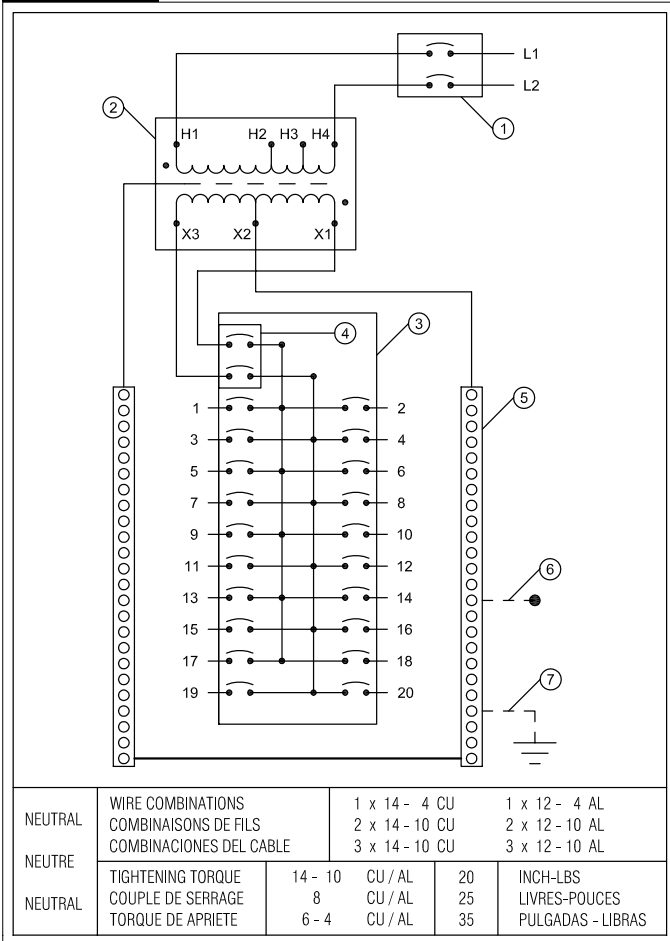

- 1 - Main Breaker
- 2 - Transformer
- 3 - Panel Board
- 4 - Panel Board Feed Breaker
- 5 - Neutral
- 6 - Bond When Required
- 7 - Ground When Required

- The maximum continuous load current not to exceed 100% of the transformer nominal current.
- The maximum continuous load current for the branch circuits not to exceed 80% of the ratings of the circuit breakers employed in other than motor circuits.
- Maximum short-circuit capacity 10,000 amps

GENERAL INFORMATION

ALPHA NUMERIC PART NUMBER INDEX

Catalog Part No.	Catalog Page No.	Catalog Part No.	Catalog Page No.	Catalog Part No.	Catalog Page No.
2909B.2.....	146	3009B1.5.....	147	C1F003GES.....	231
2909B.4.....	146	3009B10.....	147	C1F003HRS.....	232
2909B.5.....	146	3009B12.....	147	C1F003JES.....	233
2909B.75.....	146	3009B16.....	147	C1F003LES.....	232
2909B1.....	146	3009B2.....	147	C1F003PES.....	233
2909B1.5.....	146	3009B2.5.....	147	C1F003WES.....	231
2909B10.....	146	3009B3.....	147	C1F003XES.....	233
2909B12.....	146	3009B4.....	147	C1F005CES.....	232
2909B16.....	146	3009B5.....	147	C1F005EES.....	231
2909B2.....	146	3009B6.....	147	C1F005GES.....	231
2909B2.5.....	146	3009B8.....	147	C1F005HRS.....	232
2909B3.....	146	3009C.3.....	147	C1F005JES.....	233
2909B4.....	146	3009C.5.....	147	C1F005LES.....	232
2909B5.....	146	3009C.75.....	147	C1F005PES.....	233
2909B6.....	146	3009C1.....	147	C1F005WES.....	231
2909B8.....	146	3009C1.5.....	147	C1F005XES.....	233
2909C.2.....	146	3009C10.....	147	C1F007CES.....	232
2909C.4.....	146	3009C12.....	147	C1F007EES.....	231
2909C.5.....	146	3009C16.....	147	C1F007GES.....	231
2909C.75.....	146	3009C2.....	147	C1F007HRS.....	232
2909C1.....	146	3009C2.5.....	147	C1F007JES.....	233
2909C1.5.....	146	3009C3.....	147	C1F007LES.....	232
2909C10.....	146	3009C4.....	147	C1F007PES.....	233
2909C12.....	146	3009C5.....	147	C1F007WES.....	231
2909C16.....	146	3009C6.....	147	C1F007XES.....	233
2909C2.....	146	3009C8.....	147	C1F010CES.....	232
2909C2.5.....	146	3009D.3.....	147	C1F010EES.....	231
2909C3.....	146	3009D.5.....	147	C1F010GES.....	231
2909C4.....	146	3009D.75.....	147	C1F010HRS.....	232
2909C5.....	146	3009D1.....	147	C1F010JES.....	233
2909C6.....	146	3009D1.5.....	147	C1F010LES.....	232
2909C8.....	146	3009D10.....	147	C1F010PES.....	233
2909D.2.....	146	3009D12.....	147	C1F010WES.....	231
2909D.4.....	146	3009D16.....	147	C1F010XES.....	233
2909D.5.....	146	3009D2.....	147	C1F015LES.....	232
2909D.75.....	146	3009D2.5.....	147	C1F015PES.....	233
2909D1.....	146	3009D3.....	147	C1F025LES.....	232
2909D1.5.....	146	3009D4.....	147	C1F025PES.....	233
2909D10.....	146	3009D5.....	147	C1F037LES.....	232
2909D12.....	146	3009D6.....	147	C1F037PES.....	233
2909D16.....	146	3009D8.....	147	C1F1C0CES.....	232
2909D2.....	146	C1F002CES.....	232	C1F1C0EES.....	231
2909D2.5.....	146	C1F002EES.....	231	C1F1C0GES.....	231
2909D3.....	146	C1F002GES.....	231	C1F1C0HRS.....	232
2909D4.....	146	C1F002HRS.....	232	C1F1C0JES.....	233
2909D5.....	146	C1F002JES.....	233	C1F1C0LES.....	232
2909D6.....	146	C1F002LES.....	232	C1F1C0PES.....	233
2909D8.....	146	C1F002PES.....	233	C1F1C0WES.....	231
3009B.3.....	147	C1F002WES.....	231	C1F1C0XES.....	233
3009B.5.....	147	C1F002XES.....	233	C1F1C5CES.....	232
3009B.75.....	147	C1F003CES.....	232	C1F1C5EES.....	231
3009B1.....	147	C1F003EES.....	231	C1F1C5GES.....	231

GENERAL
INFORMATION



GENERAL INFORMATION

ALPHA NUMERIC PART NUMBER INDEX

Catalog Part No.	Catalog Page No.	Catalog Part No.	Catalog Page No.	Catalog Part No.	Catalog Page No.
C1F1C5HRS	232	C1FC50EE	231	C3F015DKS	235
C1F1C5JES	233	C1FC50GE	231	C3F015KBS	236
C1F1C5LES	232	C1FC50HR	232	C3F015KDS	236
C1F1C5PES	233	C1FC50JE	233	C3F015PBS	236
C1F1C5WES	231	C1FC50LE	232	C3F015PDS	236
C1F1C5XES	233	C1FC50PE	233	C3F030BBS	235
C1FC05CE	232	C1FC50WE	231	C3F030BKS	235
C1FC05EE	231	C1FC50XE	233	C3F030DBS	235
C1FC05GE	231	C1FC75CES	232	C3F030DKS	235
C1FC05HR	232	C1FC75EES	231	C3F030KBS	236
C1FC05JE	233	C1FC75GES	231	C3F030KDS	236
C1FC05LE	232	C1FC75HRS	232	C3F030PBS	236
C1FC05PE	233	C1FC75JES	233	C3F030PDS	236
C1FC05WE	231	C1FC75LES	232	C3F045BBS	235
C1FC05XE	233	C1FC75PES	233	C3F045BKS	235
C1FC10CE	232	C1FC75WES	231	C3F045DBS	235
C1FC10EE	231	C1FC75XES	233	C3F045DKS	235
C1FC10GE	231	C3F002BBS	235	C3F045KBS	236
C1FC10HR	232	C3F002BKS	235	C3F045KDS	236
C1FC10JE	233	C3F002DBS	235	C3F045PBS	236
C1FC10LE	232	C3F002DKS	235	C3F045PDS	236
C1FC10PE	233	C3F002KBS	236	C3F075BBS	235
C1FC10WE	231	C3F002KDS	236	C3F075BKS	235
C1FC10XE	233	C3F002PBS	236	C3F075DBS	235
C1FC15CE	232	C3F002PDS	236	C3F075DKS	235
C1FC15EE	231	C3F003BBS	235	C3F075KBS	236
C1FC15GE	231	C3F003BKS	235	C3F075KDS	236
C1FC15HR	232	C3F003DBS	235	C3F075PBS	236
C1FC15JE	233	C3F003DKS	235	C3F075PDS	236
C1FC15LE	232	C3F003KBS	236	DE007BK	133
C1FC15PE	233	C3F003KDS	236	DE007BKCN	137
C1FC15WE	231	C3F003PBS	236	DE007CC	133
C1FC15XE	233	C3F003PDS	236	DE007CCCN	138
C1FC25CE	232	C3F006BBS	235	DE007JC	134
C1FC25EE	231	C3F006BKS	235	DE007JCCN	138
C1FC25GE	231	C3F006DBS	235	DE007JH	134
C1FC25HR	232	C3F006DKS	235	DE007JHCN	139
C1FC25JE	233	C3F006KBS	236	DE007JJ	135
C1FC25LE	232	C3F006KDS	236	DE007JJCN	139
C1FC25PE	233	C3F006PBS	236	DE007KD	135
C1FC25WE	231	C3F006PDS	236	DE007KDCN	140
C1FC25XE	233	C3F009BBS	235	DE007KK	136
C1FC35CE	232	C3F009BKS	235	DE007KKCN	140
C1FC35EE	231	C3F009DBS	235	DE007NJ	136
C1FC35GE	231	C3F009DKS	235	DE007NJCN	141
C1FC35HR	232	C3F009KBS	236	DE007NN	137
C1FC35JE	233	C3F009KDS	236	DE007NNCN	141
C1FC35LE	232	C3F009PBS	236	DE011BK	133
C1FC35PE	233	C3F009PDS	236	DE011BKCN	137
C1FC35WE	231	C3F015BBS	235	DE011CC	133
C1FC35XE	233	C3F015BKS	235	DE011CCCN	138
C1FC50CE	232	C3F015DBS	235	DE011JC	134

GENERAL
INFORMATION



GENERAL INFORMATION

ALPHA NUMERIC PART NUMBER INDEX

Catalog Part No.	Catalog Page No.	Catalog Part No.	Catalog Page No.	Catalog Part No.	Catalog Page No.
DE011JCCN.....	138	DE027CCC.....	138	DE051BKC.....	137
DE011JH.....	134	DE027JC.....	134	DE051CC.....	133
DE011JHCN.....	139	DE027JCCN.....	138	DE051CCC.....	138
DE011JJ.....	135	DE027JH.....	134	DE051JC.....	134
DE011JJCN.....	139	DE027JHCN.....	139	DE051JCC.....	138
DE011KD.....	135	DE027JJ.....	135	DE051JH.....	134
DE011KDCN.....	140	DE027JJC.....	139	DE051JHC.....	139
DE011KK.....	136	DE027JK.....	135	DE051JJ.....	135
DE011KKCN.....	140	DE027KDCN.....	140	DE051JJC.....	139
DE011NJ.....	136	DE027KK.....	136	DE051KD.....	135
DE011NJCN.....	141	DE027KKCN.....	140	DE051KDC.....	140
DE011NN.....	137	DE027KN.....	136	DE051KK.....	136
DE011NNCN.....	141	DE027NJC.....	141	DE051KKC.....	140
DE014BK.....	133	DE027NN.....	137	DE051NJ.....	136
DE014BKCN.....	137	DE027NNCN.....	141	DE051NJC.....	141
DE014CC.....	133	DE034BK.....	133	DE051NN.....	137
DE014CCCN.....	138	DE034BKC.....	137	DE051NNC.....	141
DE014JC.....	134	DE034CC.....	133	DE063BK.....	133
DE014JCCN.....	138	DE034CCC.....	138	DE063BKC.....	137
DE014JH.....	134	DE034JC.....	134	DE063CC.....	133
DE014JHCN.....	139	DE034JCC.....	138	DE063CCC.....	138
DE014JJ.....	135	DE034JH.....	134	DE063JC.....	134
DE014JJCN.....	139	DE034JHC.....	139	DE063JCC.....	138
DE014KD.....	135	DE034JJ.....	135	DE063JH.....	134
DE014KDCN.....	140	DE034JJC.....	139	DE063JHC.....	139
DE014KK.....	136	DE034KD.....	135	DE063JJ.....	135
DE014KKCN.....	140	DE034KDCN.....	140	DE063JJC.....	139
DE014NJ.....	136	DE034KK.....	136	DE063KD.....	135
DE014NJCN.....	141	DE034KKCN.....	140	DE063KDC.....	140
DE014NN.....	137	DE034KN.....	136	DE063KK.....	136
DE014NNCN.....	141	DE034NJC.....	141	DE063KKC.....	140
DE020BK.....	133	DE034NN.....	137	DE063NJ.....	136
DE020BKC.....	137	DE034NNCN.....	141	DE063NJC.....	141
DE020CC.....	133	DE040BK.....	133	DE063NN.....	137
DE020CCC.....	138	DE040BKC.....	137	DE063NNC.....	141
DE020JC.....	134	DE040CC.....	133	DE075BK.....	133
DE020JCCN.....	138	DE040CCC.....	138	DE075BKC.....	137
DE020JH.....	134	DE040JC.....	134	DE075CC.....	133
DE020JHCN.....	139	DE040JCC.....	138	DE075CCC.....	138
DE020JJ.....	135	DE040JH.....	134	DE075JC.....	134
DE020JJCN.....	139	DE040JHC.....	139	DE075JCC.....	138
DE020KD.....	135	DE040JJ.....	135	DE075JH.....	134
DE020KDCN.....	140	DE040JJC.....	139	DE075JHC.....	139
DE020KK.....	136	DE040KD.....	135	DE075JJ.....	135
DE020KKCN.....	140	DE040KDC.....	140	DE075JJC.....	139
DE020NJ.....	136	DE040KK.....	136	DE075KD.....	135
DE020NJCN.....	141	DE040KKC.....	140	DE075KDC.....	140
DE020NN.....	137	DE040KN.....	136	DE075KK.....	136
DE020NNCN.....	141	DE040NJC.....	141	DE075KKC.....	140
DE027BK.....	133	DE040NN.....	137	DE075NJ.....	136
DE027BKC.....	137	DE040NNCN.....	141	DE075NJC.....	141
DE027CC.....	133	DE051BK.....	133	DE075NN.....	137

GENERAL INFORMATION



GENERAL INFORMATION

ALPHA NUMERIC PART NUMBER INDEX

Catalog Part No.	Catalog Page No.	Catalog Part No.	Catalog Page No.	Catalog Part No.	Catalog Page No.
DE075NNC	141	DE145NJC	141	DE275KKC	140
DE093BK	133	DE145NN	137	DE275NJ	136
DE093BKC	137	DE145NNC	141	DE275NJC	141
DE093CC	133	DE175BK	133	DE275NN	137
DE093CCC	138	DE175BKC	137	DE275NNC	141
DE093JC	134	DE175CC	133	DE330BK	133
DE093JCC	138	DE175CCC	138	DE330BKC	137
DE093JH	134	DE175JC	134	DE330CC	133
DE093JHC	139	DE175JCC	138	DE330CCC	138
DE093JJ	135	DE175JH	134	DE330JC	134
DE093JJC	139	DE175JHC	139	DE330JCC	138
DE093KD	135	DE175JJ	135	DE330JH	134
DE093KDC	140	DE175JJC	139	DE330JHC	139
DE093KK	136	DE175KD	135	DE330JJ	135
DE093KKC	140	DE175KDC	140	DE330JJC	139
DE093NJ	136	DE175KK	136	DE330KD	135
DE093NJC	141	DE175KKC	140	DE330KDC	140
DE093NN	137	DE175NJ	136	DE330KK	136
DE093NNC	141	DE175NJC	141	DE330KKC	140
DE118BK	133	DE175NN	137	DE330NJ	136
DE118BKC	137	DE175NNC	141	DE330NJC	141
DE118CC	133	DE220BK	133	DE330NN	137
DE118CCC	138	DE220BKC	137	DE330NNC	141
DE118JC	134	DE220CC	133	DE440BK	133
DE118JCC	138	DE220CCC	138	DE440BKC	137
DE118JH	134	DE220JC	134	DE440CC	133
DE118JHC	139	DE220JCC	138	DE440CCC	138
DE118JJ	135	DE220JH	134	DE440JC	134
DE118JJC	139	DE220JHC	139	DE440JCC	138
DE118KD	135	DE220JJ	135	DE440JH	134
DE118KDC	140	DE220JJC	139	DE440JHC	139
DE118KK	136	DE220KD	135	DE440JJ	135
DE118KKC	140	DE220KDC	140	DE440JJC	139
DE118NJ	136	DE220KK	136	DE440KD	135
DE118NJC	141	DE220KKC	140	DE440KDC	140
DE118NN	137	DE220NJ	136	DE440KK	136
DE118NNC	141	DE220NJC	141	DE440KKC	140
DE145BK	133	DE220NN	137	DE440NJ	136
DE145BKC	137	DE220NNC	141	DE440NJC	141
DE145CC	133	DE275BK	133	DE440NN	137
DE145CCC	138	DE275BKC	137	DE440NNC	141
DE145JC	134	DE275CC	133	DE550BK	133
DE145JCC	138	DE275CCC	138	DE550BKC	137
DE145JH	134	DE275JC	134	DE550CC	133
DE145JHC	139	DE275JCC	138	DE550CCC	138
DE145JJ	135	DE275JH	134	DE550JC	134
DE145JJC	139	DE275JHC	139	DE550JCC	138
DE145KD	135	DE275JJ	135	DE550JH	134
DE145KDC	140	DE275JJC	139	DE550JHC	139
DE145KK	136	DE275KD	135	DE550JJ	135
DE145KKC	140	DE275KDC	140	DE550JJC	139
DE145NJ	136	DE275KK	136	DE550KD	135

GENERAL INFORMATION



GENERAL INFORMATION

ALPHA NUMERIC PART NUMBER INDEX

Catalog Part No.	Catalog Page No.	Catalog Part No.	Catalog Page No.	Catalog Part No.	Catalog Page No.
DE550KDC	140	DM011JJCN	128	DM027JHCN	128
DE550KK	136	DM011KD	124	DM027JJ	124
DE550KKC	140	DM011KDCN	129	DM027JJCN	128
DE550NJ	136	DM011KK	125	DM027KD	124
DE550NJC	141	DM011KKCN	129	DM027KDCN	129
DE550NN	137	DM011NJ	125	DM027KK	125
DE550NNC	141	DM011NJCN	130	DM027KKCN	129
DE660BK	133	DM011NN	126	DM027NJ	125
DE660BKC	137	DM011NNCN	130	DM027NJCN	130
DE660CC	133	DM014BK	122	DM027NN	126
DE660CCC	138	DM014BKCN	126	DM027NNCN	130
DE660JC	134	DM014CC	122	DM034BK	122
DE660JCC	138	DM014CCCN	127	DM034BKC	126
DE660JH	134	DM014JC	123	DM034CC	122
DE660JHC	139	DM014JCCN	127	DM034CCC	127
DE660JJ	135	DM014JH	123	DM034JC	123
DE660JJC	139	DM014JHCN	128	DM034JCC	127
DE660KD	135	DM014JJ	124	DM034JH	123
DE660KDC	140	DM014JJCN	128	DM034JHC	128
DE660KK	136	DM014KD	124	DM034JJ	124
DE660KKC	140	DM014KDCN	129	DM034JJC	128
DE660NJ	136	DM014KK	125	DM034KD	124
DE660NJC	141	DM014KKCN	129	DM034KDCN	129
DE660NN	137	DM014NJ	125	DM034KK	125
DE660NNC	141	DM014NJCN	130	DM034KKCN	129
DM007BK	122	DM014NN	126	DM034NJ	125
DM007BKCN	126	DM014NNCN	130	DM034NJCN	130
DM007CC	122	DM020BK	122	DM034NN	126
DM007CCCN	127	DM020BKC	126	DM034NNCN	130
DM007JC	123	DM020CC	122	DM040BK	122
DM007JCCN	127	DM020CCC	127	DM040BKC	126
DM007JH	123	DM020JC	123	DM040CC	122
DM007JHCN	128	DM020JCCN	127	DM040CCC	127
DM007JJ	124	DM020JH	123	DM040JC	123
DM007JJCN	128	DM020JHCN	128	DM040JCC	127
DM007KD	124	DM020JJ	124	DM040JH	123
DM007KDCN	129	DM020JJCN	128	DM040JHC	128
DM007KK	125	DM020KD	124	DM040JJ	124
DM007KKCN	129	DM020KDCN	129	DM040JJC	128
DM007NJ	125	DM020KK	125	DM040KD	124
DM007NJCN	130	DM020KKCN	129	DM040KDC	129
DM007NN	126	DM020NJ	125	DM040KK	125
DM007NNCN	130	DM020NJCN	130	DM040KKC	129
DM011BK	122	DM020NN	126	DM040NJ	125
DM011BKCN	126	DM020NNCN	130	DM040NJCN	130
DM011CC	122	DM027BK	122	DM040NN	126
DM011CCCN	127	DM027BKC	126	DM040NNCN	130
DM011JC	123	DM027CC	122	DM051BK	122
DM011JCCN	127	DM027CCC	127	DM051BKC	126
DM011JH	123	DM027JC	123	DM051CC	122
DM011JHCN	128	DM027JCCN	127	DM051CCC	127
DM011JJ	124	DM027JH	123	DM051JC	123

GENERAL
INFORMATION



GENERAL INFORMATION

ALPHA NUMERIC PART NUMBER INDEX

Catalog Part No.	Catalog Page No.	Catalog Part No.	Catalog Page No.	Catalog Part No.	Catalog Page No.
DM051JCC	127	DM093CCC	127	DM175BKC	126
DM051JH	123	DM093JC	123	DM175CC	122
DM051JHC	128	DM093JCC	127	DM175CCC	127
DM051JJ	124	DM093JH	123	DM175JC	123
DM051JJC	128	DM093JHC	128	DM175JCC	127
DM051KD	124	DM093JJ	124	DM175JH	123
DM051KDC	129	DM093JJC	128	DM175JHC	128
DM051KK	125	DM093KD	124	DM175JJ	124
DM051KKC	129	DM093KDC	129	DM175JJC	128
DM051NJ	125	DM093KK	125	DM175KD	124
DM051NJC	130	DM093KKC	129	DM175KDC	129
DM051NN	126	DM093NJ	125	DM175KK	125
DM051NNC	130	DM093NJC	130	DM175KKC	129
DM063BK	122	DM093NN	126	DM175NJ	125
DM063BKC	126	DM093NNC	130	DM175NJC	130
DM063CC	122	DM118BK	122	DM175NN	126
DM063CCC	127	DM118BKC	126	DM175NNC	130
DM063JC	123	DM118CC	122	DM220BK	122
DM063JCC	127	DM118CCC	127	DM220BKC	126
DM063JH	123	DM118JC	123	DM220CC	122
DM063JHC	128	DM118JCC	127	DM220CCC	127
DM063JJ	124	DM118JH	123	DM220JC	123
DM063JJC	128	DM118JHC	128	DM220JCC	127
DM063KD	124	DM118JJ	124	DM220JH	123
DM063KDC	129	DM118JJC	128	DM220JHC	128
DM063KK	125	DM118KD	124	DM220JJ	124
DM063KKC	129	DM118KDC	129	DM220JJC	128
DM063NJ	125	DM118KK	125	DM220KD	124
DM063NJC	130	DM118KKC	129	DM220KDC	129
DM063NN	126	DM118NJ	125	DM220KK	125
DM063NNC	130	DM118NJC	130	DM220KKC	129
DM075BK	122	DM118NN	126	DM220NJ	125
DM075BKC	126	DM118NNC	130	DM220NJC	130
DM075CC	122	DM145BK	122	DM220NN	126
DM075CCC	127	DM145BKC	126	DM220NNC	130
DM075JC	123	DM145CC	122	DM275BK	122
DM075JCC	127	DM145CCC	127	DM275BKC	126
DM075JH	123	DM145JC	123	DM275CC	122
DM075JHC	128	DM145JCC	127	DM275CCC	127
DM075JJ	124	DM145JH	123	DM275JC	123
DM075JJC	128	DM145JHC	128	DM275JCC	127
DM075KD	124	DM145JJ	124	DM275JH	123
DM075KDC	129	DM145JJC	128	DM275JHC	128
DM075KK	125	DM145KD	124	DM275JJ	124
DM075KKC	129	DM145KDC	129	DM275JJC	128
DM075NJ	125	DM145KK	125	DM275KD	124
DM075NJC	130	DM145KKC	129	DM275KDC	129
DM075NN	126	DM145NJ	125	DM275KK	125
DM075NNC	130	DM145NJC	130	DM275KKC	129
DM093BK	122	DM145NN	126	DM275NJ	125
DM093BKC	126	DM145NNC	130	DM275NJC	130
DM093CC	122	DM175BK	122	DM275NN	126

GENERAL INFORMATION

ALPHA NUMERIC PART NUMBER INDEX

Catalog Part No.	Catalog Page No.	Catalog Part No.	Catalog Page No.	Catalog Part No.	Catalog Page No.
DM275NNC.....	130	DM550NJC.....	130	FS150MQMJ.....	57
DM330BK.....	122	DM550NN.....	126	FS150NJ.....	59
DM330BKC.....	126	DM550NNC.....	130	FS150PR.....	59
DM330CC.....	122	DM660BK.....	122	FS150QR.....	57
DM330CCC.....	127	DM660BKC.....	126	FS150SP.....	60
DM330JC.....	123	DM660CC.....	122	FS150SR.....	60
DM330JCC.....	127	DM660CCC.....	127	FS2000ACP.....	56
DM330JH.....	123	DM660JC.....	123	FS2000MQMJ.....	57
DM330JHC.....	128	DM660JCC.....	127	FS250ACP.....	56
DM330JJ.....	124	DM660JH.....	123	FS250AR.....	56
DM330JJC.....	128	DM660JHC.....	128	FS250KHP.....	58
DM330KD.....	124	DM660JJ.....	124	FS250KHR.....	58
DM330KDC.....	129	DM660JJC.....	128	FS250MQMJ.....	57
DM330KK.....	125	DM660KD.....	124	FS250NJ.....	59
DM330KKC.....	129	DM660KDC.....	129	FS250PR.....	59
DM330NJ.....	125	DM660KK.....	125	FS250QR.....	57
DM330NJC.....	130	DM660KKC.....	129	FS250SP.....	60
DM330NN.....	126	DM660NJ.....	125	FS250SR.....	60
DM330NNC.....	130	DM660NJC.....	130	FS3000ACP.....	56
DM440BK.....	122	DM660NN.....	126	FS3000MQMJ.....	57
DM440BKC.....	126	DM660NNC.....	130	FS350ACP.....	56
DM440CC.....	122	FG1.....	45	FS350AR.....	56
DM440CCC.....	127	FG2.....	45	FS350KHP.....	58
DM440JC.....	123	FG3.....	45	FS350KHR.....	58
DM440JCC.....	127	FG4.....	45	FS350MQMJ.....	57
DM440JH.....	123	FG5.....	45	FS350NJ.....	59
DM440JHC.....	128	FGF1.....	45	FS350PR.....	59
DM440JJ.....	124	FGF2.....	45	FS350QR.....	57
DM440JJC.....	128	FS1000ACP.....	56	FS350SP.....	60
DM440KD.....	124	FS1000KHP.....	58	FS350SR.....	60
DM440KDC.....	129	FS1000MQMJ.....	57	FS5000ACP.....	56
DM440KK.....	125	FS1000NJ.....	59	FS5000MQMJ.....	57
DM440KKC.....	129	FS1000SP.....	60	FS500ACP.....	56
DM440NJ.....	125	FS100ACP.....	56	FS500AR.....	56
DM440NJC.....	130	FS100AR.....	56	FS500KHP.....	58
DM440NN.....	126	FS100KHP.....	58	FS500KHR.....	58
DM440NNC.....	130	FS100KHR.....	58	FS500MQMJ.....	57
DM550BK.....	122	FS100MQMJ.....	57	FS500NJ.....	59
DM550BKC.....	126	FS100NJ.....	59	FS500PR.....	59
DM550CC.....	122	FS100PR.....	59	FS500QR.....	57
DM550CCC.....	127	FS100QR.....	57	FS500SP.....	60
DM550JC.....	123	FS100SP.....	60	FS500SR.....	60
DM550JCC.....	127	FS100SR.....	60	FS50ACP.....	56
DM550JH.....	123	FS1500ACP.....	56	FS50AR.....	56
DM550JHC.....	128	FS1500KHP.....	58	FS50KHP.....	58
DM550JJ.....	124	FS1500MQMJ.....	57	FS50KHR.....	58
DM550JJC.....	128	FS1500NJ.....	59	FS50MQMJ.....	57
DM550KD.....	124	FS1500SP.....	60	FS50NJ.....	59
DM550KDC.....	129	FS150ACP.....	56	FS50PR.....	59
DM550KK.....	125	FS150AR.....	56	FS50QR.....	57
DM550KKC.....	129	FS150KHP.....	58	FS50SP.....	60
DM550NJ.....	125	FS150KHR.....	58	FS50SR.....	60

GENERAL
INFORMATION



GENERAL INFORMATION

ALPHA NUMERIC PART NUMBER INDEX

Catalog Part No.	Catalog Page No.	Catalog Part No.	Catalog Page No.	Catalog Part No.	Catalog Page No.
FS750ACP	56	H1EM030PK30	212	H1EM112BB30	211
FS750KHP	58	H1EM030PK30S	208	H1EM112BB30S	207
FS750MQMJ	57	H1EM045BB00	209	H1EM112BK00	209
FS750NJ	59	H1EM045BB00S	205	H1EM112BK00S	205
FS750SP	60	H1EM045BB30	211	H1EM112BK30	211
FSFH1	61	H1EM045BB30S	207	H1EM112BK30S	207
H1EM015BB00	209	H1EM045BK00	209	H1EM112KB00	209
H1EM015BB00S	205	H1EM045BK00S	205	H1EM112KB00S	205
H1EM015BB30	211	H1EM045BK30	211	H1EM112KB30	211
H1EM015BB30S	207	H1EM045BK30S	207	H1EM112KB30S	207
H1EM015BK00	209	H1EM045KB00	209	H1EM112KK00	210
H1EM015BK00S	205	H1EM045KB00S	205	H1EM112KK00S	206
H1EM015BK30	211	H1EM045KB30	211	H1EM112KK30	212
H1EM015BK30S	207	H1EM045KB30S	207	H1EM112KK30S	208
H1EM015KB00	209	H1EM045KK00	210	H1EM112PB00	210
H1EM015KB00S	205	H1EM045KK00S	206	H1EM112PB00S	206
H1EM015KB30	211	H1EM045KK30	212	H1EM112PB30	212
H1EM015KB30S	207	H1EM045KK30S	208	H1EM112PB30S	208
H1EM015KK00	210	H1EM045PB00	210	H1EM112PK00	210
H1EM015KK00S	206	H1EM045PB00S	206	H1EM112PK00S	206
H1EM015KK30	212	H1EM045PB30	212	H1EM112PK30	212
H1EM015KK30S	208	H1EM045PB30S	208	H1EM112PK30S	208
H1EM015PB00	210	H1EM045PK00	210	H1EM150BB00	209
H1EM015PB00S	206	H1EM045PK00S	206	H1EM150BB00S	205
H1EM015PB30	212	H1EM045PK30	212	H1EM150BB30	211
H1EM015PB30S	208	H1EM045PK30S	208	H1EM150BB30S	207
H1EM015PK00	210	H1EM075BB00	209	H1EM150BK00	209
H1EM015PK00S	206	H1EM075BB00S	205	H1EM150BK00S	205
H1EM015PK30	212	H1EM075BB30	211	H1EM150BK30	211
H1EM015PK30S	208	H1EM075BB30S	207	H1EM150BK30S	207
H1EM030BB00	209	H1EM075BK00	209	H1EM150KB00	209
H1EM030BB00S	205	H1EM075BK00S	205	H1EM150KB00S	205
H1EM030BB30	211	H1EM075BK30	211	H1EM150KB30	211
H1EM030BB30S	207	H1EM075BK30S	207	H1EM150KB30S	207
H1EM030BK00	209	H1EM075KB00	209	H1EM150KK00	210
H1EM030BK00S	205	H1EM075KB00S	205	H1EM150KK00S	206
H1EM030BK30	211	H1EM075KB30	211	H1EM150KK30	212
H1EM030BK30S	207	H1EM075KB30S	207	H1EM150KK30S	208
H1EM030KB00	209	H1EM075KK00	210	H1EM150PB00	210
H1EM030KB00S	205	H1EM075KK00S	206	H1EM150PB00S	206
H1EM030KB30	211	H1EM075KK30	212	H1EM150PB30	212
H1EM030KB30S	207	H1EM075KK30S	208	H1EM150PB30S	208
H1EM030KK00	210	H1EM075PB00	210	H1EM150PK00	210
H1EM030KK00S	206	H1EM075PB00S	206	H1EM150PK00S	206
H1EM030KK30	212	H1EM075PB30	212	H1EM150PK30	212
H1EM030KK30S	208	H1EM075PB30S	208	H1EM150PK30S	208
H1EM030PB00	210	H1EM075PK00	210	H1EM225BB00	209
H1EM030PB00S	206	H1EM075PK00S	206	H1EM225BB00S	205
H1EM030PB30	212	H1EM075PK30	212	H1EM225BB30	211
H1EM030PB30S	208	H1EM075PK30S	208	H1EM225BB30S	207
H1EM030PK00	210	H1EM112BB00	209	H1EM225BK00	209
H1EM030PK00S	206	H1EM112BB00S	205	H1EM225BK00S	205

GENERAL
INFORMATION



GENERAL INFORMATION

ALPHA NUMERIC PART NUMBER INDEX

Catalog Part No.	Catalog Page No.	Catalog Part No.	Catalog Page No.	Catalog Part No.	Catalog Page No.
H1EM225BK30	211	H1EM500KB30	211	MV1S025RE	253
H1EM225BK30S	207	H1EM500KB30S	207	MV1S025RECN	254
H1EM225KB00	209	H1EM500KK00	210	MV1S025SE	253
H1EM225KB00S	205	H1EM500KK00S	206	MV1S025SECN	254
H1EM225KB30	211	H1EM500KK30	212	MV1S037RE	253
H1EM225KB30S	207	H1EM500KK30S	208	MV1S037RECN	254
H1EM225KK00	210	H1EM500PB00	210	MV1S037SE	253
H1EM225KK00S	206	H1EM500PB00S	206	MV1S037SECN	254
H1EM225KK30	212	H1EM500PB30	212	MV1S050RE	253
H1EM225KK30S	208	H1EM500PB30S	208	MV1S050RECN	254
H1EM225PB00	210	H1EM500PK00	210	MV1S050SE	253
H1EM225PB00S	206	H1EM500PK00S	206	MV1S050SECN	254
H1EM225PB30	212	H1EM500PK30	212	MV1S075RE	253
H1EM225PB30S	208	H1EM500PK30S	208	MV1S075REC	254
H1EM225PK00	210	H1EM750BB00	209	MV1S075SE	253
H1EM225PK00S	206	H1EM750BB00S	205	MV1S075SECN	254
H1EM225PK30	212	H1EM750BB30	211	MV1S100RE	253
H1EM225PK30S	208	H1EM750BB30S	207	MV1S100REC	254
H1EM300BB00	209	H1EM750BK00	209	MV1S100SE	253
H1EM300BB00S	205	H1EM750BK00S	205	MV1S100SEC	254
H1EM300BB30	211	H1EM750BK30	211	MV1S150RE	253
H1EM300BB30S	207	H1EM750BK30S	207	MV1S150REC	254
H1EM300BK00	209	H1EM750KB00	209	MV1S150SE	253
H1EM300BK00S	205	H1EM750KB00S	205	MV1S150SEC	254
H1EM300BK30	211	H1EM750KB30	211	MV1S167RE	253
H1EM300BK30S	207	H1EM750KB30S	207	MV1S167REC	254
H1EM300KB00	209	H1EM750KK00	210	MV1S167SE	253
H1EM300KB00S	205	H1EM750KK00S	206	MV1S167SEC	254
H1EM300KB30	211	H1EM750KK30	212	MV1S250RE	253
H1EM300KB30S	207	H1EM750KK30S	208	MV1S250REC	254
H1EM300KK00	210	H1EM750PB00	210	MV1S250SE	253
H1EM300KK00S	206	H1EM750PB00S	206	MV1S250SEC	254
H1EM300KK30	212	H1EM750PB30	212	MV1S333RE	253
H1EM300KK30S	208	H1EM750PB30S	208	MV1S333REC	254
H1EM300PB00	210	H1EM750PK00	210	MV1S333SE	253
H1EM300PB00S	206	H1EM750PK00S	206	MV1S333SEC	254
H1EM300PB30	212	H1EM750PK30	212	MV3S015RB	255
H1EM300PB30S	208	H1EM750PK30S	208	MV3S015RBCN	257
H1EM300PK00	210	M1PC005LESF	226	MV3S015RK	255
H1EM300PK00S	206	M1PC005LESF7	226	MV3S015RKCN	257
H1EM300PK30	212	M1PC007LESF	226	MV3S015RP	255
H1EM300PK30S	208	M1PC007LESF7	226	MV3S015RPCN	257
H1EM500BB00	209	M1PC010LESF	226	MV3S015SB	256
H1EM500BB00S	205	M1PC010LESF7	226	MV3S015SBCN	258
H1EM500BB30	211	M1PC015LESF	226	MV3S015SK	256
H1EM500BB30S	207	M1PC015LESF7	226	MV3S015SKCN	258
H1EM500BK00	209	M1PC025LESF	226	MV3S015SP	256
H1EM500BK00S	205	M1PC025LESF7	226	MV3S015SPCN	258
H1EM500BK30	211	MV1S015RE	253	MV3S030RB	255
H1EM500BK30S	207	MV1S015RECN	254	MV3S030RBCN	257
H1EM500KB00	209	MV1S015SE	253	MV3S030RK	255
H1EM500KB00S	205	MV1S015SECN	254	MV3S030RKCN	257

GENERAL INFORMATION



GENERAL INFORMATION

ALPHA NUMERIC PART NUMBER INDEX

Catalog Part No.	Catalog Page No.	Catalog Part No.	Catalog Page No.	Catalog Part No.	Catalog Page No.
MV3S030RP	255	MV3S112SK	256	MV3S300RB	255
MV3S030RPCN	257	MV3S112SKCN	258	MV3S300RBC	257
MV3S030SB	256	MV3S112SP	256	MV3S300RK	255
MV3S030SBCN	258	MV3S112SPCN	258	MV3S300RKC	257
MV3S030SK	256	MV3S1250RB	255	MV3S300RP	255
MV3S030SKCN	258	MV3S1250RBC	257	MV3S300RPC	257
MV3S030SP	256	MV3S1250RK	255	MV3S300SB	256
MV3S030SPCN	258	MV3S1250RKC	257	MV3S300SBC	258
MV3S045RB	255	MV3S1250RP	255	MV3S300SK	256
MV3S045RBCN	257	MV3S1250RPC	257	MV3S300SKC	258
MV3S045RK	255	MV3S1250SB	256	MV3S300SP	256
MV3S045RKC	257	MV3S1250SBC	258	MV3S300SPC	258
MV3S045RP	255	MV3S1250SK	256	MV3S500RB	255
MV3S045RPCN	257	MV3S1250SKC	258	MV3S500RBC	257
MV3S045SB	256	MV3S1250SP	256	MV3S500RK	255
MV3S045SBCN	258	MV3S1250SPC	258	MV3S500RKC	257
MV3S045SK	256	MV3S1500RB	255	MV3S500RP	255
MV3S045SKCN	258	MV3S1500RBC	257	MV3S500RPC	257
MV3S045SP	256	MV3S1500RK	255	MV3S500SB	256
MV3S045SPCN	258	MV3S1500RKC	257	MV3S500SBC	258
MV3S075RB	255	MV3S1500RP	255	MV3S500SK	256
MV3S075RBCN	257	MV3S1500RPC	257	MV3S500SKC	258
MV3S075RK	255	MV3S1500SB	256	MV3S500SP	256
MV3S075RKC	257	MV3S1500SBC	258	MV3S500SPC	258
MV3S075RP	255	MV3S1500SK	256	MV3S750RB	255
MV3S075RPCN	257	MV3S1500SKC	258	MV3S750RBC	257
MV3S075SB	256	MV3S1500SP	256	MV3S750RK	255
MV3S075SBCN	258	MV3S1500SPC	258	MV3S750RKC	257
MV3S075SK	256	MV3S150RB	255	MV3S750RP	255
MV3S075SKCN	258	MV3S150RBCN	257	MV3S750RPC	257
MV3S075SP	256	MV3S150RK	255	MV3S750SB	256
MV3S075SPCN	258	MV3S150RKC	257	MV3S750SBC	258
MV3S1000RB	255	MV3S150RP	255	MV3S750SK	256
MV3S1000RBC	257	MV3S150RPCN	257	MV3S750SKC	258
MV3S1000RK	255	MV3S150SB	256	MV3S750SP	256
MV3S1000RKC	257	MV3S150SBCN	258	MV3S750SPC	258
MV3S1000RP	255	MV3S150SK	256	N1	264
MV3S1000RPC	257	MV3S150SKCN	258	N2	264
MV3S1000SB	256	MV3S150SP	256	NH3	260
MV3S1000SBC	258	MV3S150SPCN	258	NH3-N12	266
MV3S1000SK	256	MV3S225RB	255	NH3-N3RE	265
MV3S1000SKC	258	MV3S225RBC	257	NH3-N4	266
MV3S1000SP	256	MV3S225RK	255	NH4	260
MV3S1000SPC	258	MV3S225RKC	257	NH4-N12	266
MV3S112RB	255	MV3S225RP	255	NH4-N3RE	265
MV3S112RBCN	257	MV3S225RPC	257	NH4-N4	266
MV3S112RK	255	MV3S225SB	256	NH5	260
MV3S112RKC	257	MV3S225SBCN	258	NH5DP	272
MV3S112RP	255	MV3S225SK	256	NH5-N12	266
MV3S112RPCN	257	MV3S225SKCN	258	NH5-N4	266
MV3S112SB	256	MV3S225SP	256	NH6	260
MV3S112SBCN	258	MV3S225SPCN	258	NH6DP	272

GENERAL INFORMATION

ALPHA NUMERIC PART NUMBER INDEX

Catalog Part No.	Catalog Page No.	Catalog Part No.	Catalog Page No.	Catalog Part No.	Catalog Page No.
NH6-N12	266	NMF050BEC	163	NMF167HEC	164
NH6-N4	266	NMF050FE	161	NMF167LE	161
NJ1	261	NMF050FEC	163	NMF167LEC	163
NJ1-N12	267	NMF050HE	162	NMF167PE	162
NJ1-N3RE	265	NMF050HEC	164	NMF167PEC	164
NJ1-N4	267	NMF050LE	161	NMF167XE	162
NJ2	261	NMF050LEC	163	NMF167XEC	164
NJ2-N3RE	265	NMF050PE	162	NMK015BB	166
NJ3	261	NMF050PEC	164	NMK015BBCN	170
NJ3-N3RE	265	NMF050XE	162	NMK015BK	166
NJ4	261	NMF050XEC	164	NMK015BKCN	170
NJ6	261	NMF075BE	161	NMK015DB	166
NJ6-N3RE	265	NMF075BEC	163	NMK015DBCN	170
NJ7	261	NMF075FE	161	NMK015DK	167
NJ7-N3RE	265	NMF075FEC	163	NMK015DKCN	171
NMF015BE	161	NMF075HE	162	NMK015KB	167
NMF015BEC	163	NMF075HEC	164	NMK015KBCN	171
NMF015FE	161	NMF075LE	161	NMK015KD	167
NMF015FEC	163	NMF075LEC	163	NMK015KDCN	171
NMF015HE	162	NMF075PE	162	NMK015KK	168
NMF015HEC	164	NMF075PEC	164	NMK015KKCN	172
NMF015LE	161	NMF075XE	162	NMK015PB	168
NMF015LEC	163	NMF075XEC	164	NMK015PBCN	172
NMF015PE	162	NMF100BE	161	NMK015PD	168
NMF015PEC	164	NMF100BEC	163	NMK015PDCN	172
NMF015XE	162	NMF100FE	161	NMK015PK	169
NMF015XEC	164	NMF100FEC	163	NMK015PKCN	173
NMF025BE	161	NMF100HE	162	NMK030BB	166
NMF025BEC	163	NMF100HEC	164	NMK030BBC	170
NMF025FE	161	NMF100LE	161	NMK030BK	166
NMF025FEC	163	NMF100LEC	163	NMK030BKC	170
NMF025HE	162	NMF100PE	162	NMK030DB	166
NMF025HEC	164	NMF100PEC	164	NMK030DBC	170
NMF025LE	161	NMF100XE	162	NMK030DK	167
NMF025LEC	163	NMF100XEC	164	NMK030DKC	171
NMF025PE	162	NMF150BE	161	NMK030KB	167
NMF025PEC	164	NMF150BEC	163	NMK030KBCN	171
NMF025XE	162	NMF150FE	161	NMK030KD	167
NMF025XEC	164	NMF150FEC	163	NMK030KDCN	171
NMF037BE	161	NMF150HE	162	NMK030KK	168
NMF037BEC	163	NMF150HEC	164	NMK030KKCN	172
NMF037FE	161	NMF150LE	161	NMK030PB	168
NMF037FEC	163	NMF150LEC	163	NMK030PBCN	172
NMF037HE	162	NMF150PE	162	NMK030PD	168
NMF037HEC	164	NMF150PEC	164	NMK030PDC	172
NMF037LE	161	NMF150XE	162	NMK030PK	169
NMF037LEC	163	NMF150XEC	164	NMK030PKCN	173
NMF037PE	162	NMF167BE	161	NMK045BB	166
NMF037PEC	164	NMF167BEC	163	NMK045BBC	170
NMF037XE	162	NMF167FE	161	NMK045BK	166
NMF037XEC	164	NMF167FEC	163	NMK045BKC	170
NMF050BE	161	NMF167HE	162	NMK045DB	166

GENERAL INFORMATION



GENERAL INFORMATION

ALPHA NUMERIC PART NUMBER INDEX

Catalog Part No.	Catalog Page No.	Catalog Part No.	Catalog Page No.	Catalog Part No.	Catalog Page No.
NMK045DBC	170	NMK112PDC	172	NMK300KBC	171
NMK045DK	167	NMK112PK	169	NMK300KD	167
NMK045DKC	171	NMK112PKC	173	NMK300KDC	171
NMK045KB	167	NMK150BB	166	NMK300KK	168
NMK045KBC	171	NMK150BBC	170	NMK300KCC	172
NMK045KD	167	NMK150BK	166	NMK300PB	168
NMK045KDC	171	NMK150BKC	170	NMK300PBC	172
NMK045KK	168	NMK150DB	166	NMK300PD	168
NMK045KCC	172	NMK150DBC	170	NMK300PDC	172
NMK045PB	168	NMK150DK	167	NMK300PK	169
NMK045PBC	172	NMK150DKC	171	NMK300PKC	173
NMK045PD	168	NMK150KB	167	NMK500BB	166
NMK045PDC	172	NMK150KBC	171	NMK500BBC	170
NMK045PK	169	NMK150KD	167	NMK500BK	166
NMK045PKC	173	NMK150KDC	171	NMK500BKC	170
NMK075BB	166	NMK150KK	168	NMK500DB	166
NMK075BBC	170	NMK150KCC	172	NMK500DBC	170
NMK075BK	166	NMK150PB	168	NMK500DK	167
NMK075BKC	170	NMK150PBC	172	NMK500DKC	171
NMK075DB	166	NMK150PD	168	NMK500KB	167
NMK075DBC	170	NMK150PDC	172	NMK500KBC	171
NMK075DK	167	NMK150PK	169	NMK500KD	167
NMK075DKC	171	NMK150PKC	173	NMK500KDC	171
NMK075KB	167	NMK225BB	166	NMK500KK	168
NMK075KBC	171	NMK225BBC	170	NMK500KCC	172
NMK075KD	167	NMK225BK	166	NMK500PB	168
NMK075KDC	171	NMK225BKC	170	NMK500PBC	172
NMK075KK	168	NMK225DB	166	NMK500PD	168
NMK075KCC	172	NMK225DBC	170	NMK500PDC	172
NMK075PB	168	NMK225DK	167	NMK500PK	169
NMK075PBC	172	NMK225DKC	171	NMK500PKC	173
NMK075PD	168	NMK225KB	167	NMK750BB	166
NMK075PDC	172	NMK225KBC	171	NMK750BBC	170
NMK075PK	169	NMK225KD	167	NMK750BK	166
NMK075PKC	173	NMK225KDC	171	NMK750BKC	170
NMK112BB	166	NMK225KK	168	NMK750DB	166
NMK112BBC	170	NMK225KCC	172	NMK750DBC	170
NMK112BK	166	NMK225PB	168	NMK750DK	167
NMK112BKC	170	NMK225PBC	172	NMK750DKC	171
NMK112DB	166	NMK225PD	168	NMK750KB	167
NMK112DBC	170	NMK225PDC	172	NMK750KBC	171
NMK112DK	167	NMK225PK	169	NMK750KD	167
NMK112DKC	171	NMK225PKC	173	NMK750KDC	171
NMK112KB	167	NMK300BB	166	NMK750KK	168
NMK112KBC	171	NMK300BBC	170	NMK750KCC	172
NMK112KD	167	NMK300BK	166	NMK750PB	168
NMK112KDC	171	NMK300BKC	170	NMK750PBC	172
NMK112KK	168	NMK300DB	166	NMK750PD	168
NMK112KCC	172	NMK300DBC	170	NMK750PDC	172
NMK112PB	168	NMK300DK	167	NMK750PK	169
NMK112PBC	172	NMK300DKC	171	NMK750PKC	173
NMK112PD	168	NMK300KB	167	NMP1	273

GENERAL INFORMATION

ALPHA NUMERIC PART NUMBER INDEX

Catalog Part No.	Catalog Page No.	Catalog Part No.	Catalog Page No.	Catalog Part No.	Catalog Page No.
NMP2	273	NMT13K030PBKN	194	NMT20K112PBK	195
NMP3	273	NMT13K030PBS	194	NMT20K112PBS	195
NMP4	273	NMT13K045KBK	194	NMT20K150KBK	195
NMP5	273	NMT13K045KBS	194	NMT20K150KBS	195
NMP6	273	NMT13K045PBK	194	NMT20K150PBK	195
NMP7	273	NMT13K045PBS	194	NMT20K150PBS	195
NMT04K015KBKF	193	NMT13K075KBK	194	NMT20K225KBK	195
NMT04K015KBS	193	NMT13K075KBS	194	NMT20K225KBS	195
NMT04K015PBKF	193	NMT13K075PBK	194	NMT20K225PBK	195
NMT04K015PBS	193	NMT13K075PBS	194	NMT20K225PBS	195
NMT04K030KBKN	193	NMT13K112KBK	194	NMT20K300KBK	195
NMT04K030KBS	193	NMT13K112KBS	194	NMT20K300KBS	195
NMT04K030PBKN	193	NMT13K112PBK	194	NMT20K300PBK	195
NMT04K030PBS	193	NMT13K112PBS	194	NMT20K300PBS	195
NMT04K045KBK	193	NMT13K150KBK	194	NMT20K500KBK	195
NMT04K045KBS	193	NMT13K150KBS	194	NMT20K500KBS	195
NMT04K045PBK	193	NMT13K150PBK	194	NMT20K500PBK	195
NMT04K045PBS	193	NMT13K150PBS	194	NMT20K500PBS	195
NMT04K075KBK	193	NMT13K225KBK	194	NMT20K750KBK	195
NMT04K075KBS	193	NMT13K225KBS	194	NMT20K750KBS	195
NMT04K075PBK	193	NMT13K225PBK	194	NMT20K750PBK	195
NMT04K075PBS	193	NMT13K225PBS	194	NMT20K750PBS	195
NMT04K112KBK	193	NMT13K300KBK	194	NQ0	262
NMT04K112KBS	193	NMT13K300KBS	194	NQ1	262
NMT04K112PBK	193	NMT13K300PBK	194	NQ2	262
NMT04K112PBS	193	NMT13K300PBS	194	NQ3	262
NMT04K150KBK	193	NMT13K500KBK	194	NQ4	262
NMT04K150KBS	193	NMT13K500KBS	194	NQ5	262
NMT04K150PBK	193	NMT13K500PBK	194	NQ6	262
NMT04K150PBS	193	NMT13K500PBS	194	NQ6A	262
NMT04K225KBK	193	NMT13K750KBK	194	NQ7	262
NMT04K225KBS	193	NMT13K750KBS	194	NQ8	262
NMT04K225PBK	193	NMT13K750PBK	194	NQS10	263
NMT04K225PBS	193	NMT13K750PBS	194	NQT10	263
NMT04K300KBK	193	NMT20K015KBKF	195	NQT10GK	274
NMT04K300KBS	193	NMT20K015KBS	195	NQT11	263
NMT04K300PBK	193	NMT20K015PBKF	195	NQT11GK	274
NMT04K300PBS	193	NMT20K015PBS	195	NQT2	263
NMT04K500KBK	193	NMT20K030KBK	195	NQT2GK	274
NMT04K500KBS	193	NMT20K030KBS	195	NQT3	263
NMT04K500PBK	193	NMT20K030PBKN	195	NQT3GK	274
NMT04K500PBS	193	NMT20K030PBS	195	NQT4	263
NMT04K750KBK	193	NMT20K045KBK	195	NQT4GK	274
NMT04K750KBS	193	NMT20K045KBS	195	NQT5	263
NMT04K750PBK	193	NMT20K045PBK	195	NQT5GK	274
NMT04K750PBS	193	NMT20K045PBS	195	NQT6	263
NMT13K015KBKF	194	NMT20K075KBK	195	NQT6GK	274
NMT13K015KBS	194	NMT20K075KBS	195	NQT7	263
NMT13K015PBKF	194	NMT20K075PBK	195	NQT7GK	274
NMT13K015PBS	194	NMT20K075PBS	195	NQT8	263
NMT13K030KBKN	194	NMT20K112KBK	195	NQT8GK	274
NMT13K030KBS	194	NMT20K112KBS	195	NQT9	263

GENERAL
INFORMATION



GENERAL INFORMATION

ALPHA NUMERIC PART NUMBER INDEX

Catalog Part No.	Catalog Page No.	Catalog Part No.	Catalog Page No.	Catalog Part No.	Catalog Page No.
NQT9A	263	P150KBKF	243	PH250MGJ	43
NQT9AGK	274	P150KDKF	243	PH250MLI	42
NQT9GK	274	P150PBKF	243	PH250MQMJ	39
NQTW1	273	P150PDKF	244	PH250PG	41
NQTW2	273	P150QKKF	244	PH250PP	40
NW2	271, 272	P2	273	PH250QR	39
P002KBKB	243	PFK1	44	PH250SP	40
P002KDKB	243	PFK2	44	PH350AJ	38
P002PBKB	243	PFK3	44	PH350AR	38
P002PDKB	244	PFK4	44	PH350MBMH	41
P002QKKB	244	PFK5	44	PH350MEMX	42
P003KBKB	243	PFK6	44	PH350MGJ	43
P003KDKB	243	PFK7	44	PH350MLI	42
P003PBKB	243	PH1000AJ	38	PH350MQMJ	39
P003PDKB	244	PH1000MBMH	41	PH350PG	41
P003QKKB	244	PH1000MEMX	42	PH350PP	40
P006KBKF	243	PH1000MGJ	43	PH350QR	39
P006KDKF	243	PH1000MLI	42	PH350SP	40
P006PBKF	243	PH1000MQMJ	39	PH500AJ	38
P006PDKF	244	PH1000PG	41	PH500AR	38
P006QKKF	244	PH1000PP	40	PH500MBMH	41
P009KBKF	243	PH1000SP	40	PH500MEMX	42
P009KDKF	243	PH100AJ	38	PH500MGJ	43
P009PBKF	243	PH100AR	38	PH500MLI	42
P009PDKF	244	PH100MBMH	41	PH500MQMJ	39
P009QKKF	244	PH100MEMX	42	PH500PG	41
P015KBKF	243	PH100MGJ	43	PH500PP	40
P015KDKF	243	PH100MLI	42	PH500QR	39
P015PBKF	243	PH100MQMJ	39	PH500SP	40
P015PDKF	244	PH100PG	41	PH50AJ	38
P015QKKF	244	PH100PP	40	PH50AR	38
P030KBKF	243	PH100QR	39	PH50MBMH	41
P030KDKF	243	PH100SP	40	PH50MEMX	42
P030PBKF	243	PH1500AJ	38	PH50MGJ	43
P030PDKF	244	PH1500MBMH	41	PH50MLI	42
P030QKKF	244	PH1500MQMJ	39	PH50MQMJ	39
P045KBKF	243	PH1500PP	40	PH50PG	41
P045KDKF	243	PH150AJ	38	PH50PP	40
P045PBKF	243	PH150AR	38	PH50QR	39
P045PDKF	244	PH150MBMH	41	PH50SP	40
P045QKKF	244	PH150MEMX	42	PH750AJ	38
P075KBKF	243	PH150MGJ	43	PH750MBMH	41
P075KDKF	243	PH150MLI	42	PH750MEMX	42
P075PBKF	243	PH150MQMJ	39	PH750MGJ	43
P075PDKF	244	PH150PG	41	PH750MLI	42
P075QKKF	244	PH150PP	40	PH750MQMJ	39
P1	273	PH150QR	39	PH750PG	41
P112KBKF	243	PH150SP	40	PH750PP	40
P112KDKF	243	PH250AJ	38	PH750SP	40
P112PBKF	243	PH250AR	38	PH75AJ	38
P112PDKF	244	PH250MBMH	41	PH75AR	38
P112QKKF	244	PH250MEMX	42	PH75MBMH	41

GENERAL INFORMATION



GENERAL INFORMATION

ALPHA NUMERIC PART NUMBER INDEX

Catalog Part No.	Catalog Page No.	Catalog Part No.	Catalog Page No.	Catalog Part No.	Catalog Page No.
PH75MEMX	42	Q015PEKF	241	QC35ERCB	84,87,151
PH75MGJ	43	Q015XEKF	241	QC35ESCB	85,88,151
PH75MLI	42	Q015YEKF	240	QC35PRCB	63
PH75MQMJ	39	Q025FEKF	240	QC50DTCB	86,89,152
PH75PG	41	Q025LEKF	240	QC50ERCB	84,87,151
PH75PP	40	Q025PEKF	241	QC50ESCB	85,88,151
PH75QR	39	Q025XEKF	241	QC50FECB	240
PH75SP	40	Q025YEKF	240	QC50LECB	240
PPE1	268	Q037FEKF	240	QC50PECB	241
PPE2	268	Q037LEKF	240	QC50PRCB	63
PPE3	269	Q037PEKF	241	QC50XECB	241
PPE4	269	Q037XEKF	241	QC50YECB	240
PPE5	270	Q037YEKF	240	QC75DTCB	86,89,152
Q002DTCF	86,89,152	Q1C0DTCB	86,89,152	QC75ERCB	84,87,151
Q002ERCF	84,87,151	Q1C0ERCB	84,87,151	QC75ESCB	85,88,151
Q002ESCF	85,88,151	Q1C0ESCB	85,88,151	QC75FEKB	240
Q002FEKF	240	Q1C0FEKB	240	QC75LEKB	240
Q002LEKF	240	Q1C0LEKB	240	QC75PEKB	241
Q002PEKF	241	Q1C0PEKB	241	QC75PRCB	63
Q002PRCF	63	Q1C0PRCB	63	QC75XEBK	241
Q002XEKF	241	Q1C0XEBK	241	QC75YEBK	240
Q002YEKF	240	Q1C0YEKB	240	RC0002M12	116
Q003DTCF	86,89,152	Q1C5DTCF	86,89,152	RC0004N65	116
Q003ERCF	84,87,151	Q1C5ERCF	84,87,151	RC0008N30	116
Q003ESCF	85,88,151	Q1C5ESCF	85,88,151	RC0012N25	116
Q003FEKF	240	Q1C5FEKF	240	RC0018N15	116
Q003LEKF	240	Q1C5LEKF	240	RC0025N12	116
Q003PEKF	241	Q1C5PEKF	241	RC0035P80	116
Q003PRCF	63	Q1C5PRCF	63	RC0045P70	116
Q003XEKF	241	Q1C5XEKF	241	RC0055P50	116
Q003YEKF	240	Q1C5YEKF	240	RC0080P40	116
Q005DTCF	86,89,152	QC05DTCB	86,89,152	RC0110P30	116
Q005ERCF	84,87,151	QC05ERCB	84,87,151	RC0130P20	116
Q005ESCF	85,88,151	QC05ESCB	85,88,151	RC0160P15	116
Q005FEKF	240	QC05PRCB	63	RC0200P11	116
Q005LEKF	240	QC10DTCB	86,89,152	RC0250U90	116
Q005PEKF	241	QC10ERCB	84,87,151	RC0320U75	116
Q005PRCF	63	QC10ESCB	85,88,151	RC0400U61	116
Q005XEKF	241	QC10PRCB	63	RC0500U50	116
Q005YEKF	240	QC15DTCB	86,89,152	RC0600U40	116
Q007FEKF	240	QC15ERCB	84,87,151	RM0002M12	108
Q007LEKF	240	QC15ESCB	85,88,151	RM0002M12E	110
Q007PEKF	241	QC15PRCB	63	RM0002M20	108
Q007XEKF	241	QC20DTCB	86,89,152	RM0002M20E	110
Q007YEKF	240	QC20ERCB	84,87,151	RM0002M32	108
Q010FEKF	240	QC20ESCB	85,88,151	RM0002M32E	110
Q010LEKF	240	QC20PRCB	63	RM0004M12	108
Q010PEKF	241	QC25DTCB	86,89,152	RM0004M12E	110
Q010XEKF	241	QC25ERCB	84,87,151	RM0004M22	108
Q010YEKF	240	QC25ESCB	85,88,151	RM0004M22E	110
Q015FEKF	240	QC25PRCB	63	RM0004N30	108
Q015LEKF	240	QC35DTCB	86,89,152	RM0004N30E	110

GENERAL
INFORMATION



GENERAL INFORMATION

ALPHA NUMERIC PART NUMBER INDEX

Catalog Part No.	Catalog Page No.	Catalog Part No.	Catalog Page No.	Catalog Part No.	Catalog Page No.
RM0004N65.....	108	RM0055P85.....	108	RM0320P16.....	109
RM0004N65E.....	110	RM0055P85E.....	110	RM0320P16E.....	111
RM0004N91.....	108	RM0080P20.....	108	RM0320U40.....	109
RM0004N91E.....	110	RM0080P20E.....	110	RM0320U40E.....	111
RM0008N15.....	108	RM0080P23.....	108	RM0320U75.....	109
RM0008N15E.....	110	RM0080P23E.....	110	RM0320U75E.....	111
RM0008N30.....	108	RM0080P40.....	108	RM0320U96.....	109
RM0008N30E.....	110	RM0080P40E.....	110	RM0320U96E.....	111
RM0008N50.....	108	RM0080P70.....	108	RM0400P11.....	109
RM0008N50E.....	110	RM0080P70E.....	110	RM0400P11E.....	111
RM0008N75.....	108	RM0110P15.....	108	RM0400P14.....	109
RM0008N75E.....	110	RM0110P15E.....	110	RM0400P14E.....	111
RM0012N13.....	108	RM0110P18.....	108	RM0400U30.....	109
RM0012N13E.....	110	RM0110P18E.....	110	RM0400U30E.....	111
RM0012N25.....	108	RM0110P30.....	108	RM0400U61.....	109
RM0012N25E.....	110	RM0110P30E.....	110	RM0400U61E.....	111
RM0012N31.....	108	RM0110P45.....	108	RM0400U82.....	109
RM0012N31E.....	110	RM0110P45E.....	110	RM0400U82E.....	111
RM0012N42.....	108	RM0130P10.....	108	RM0500U25.....	109
RM0012N42E.....	110	RM0130P10E.....	110	RM0500U25E.....	111
RM0012N51.....	108	RM0130P20.....	108	RM0500U50.....	109
RM0012N51E.....	110	RM0130P20E.....	110	RM0500U50E.....	111
RM0018N15.....	108	RM0130P30.....	108	RM0500U57.....	109
RM0018N15E.....	110	RM0130P30E.....	110	RM0500U57E.....	111
RM0018N25.....	108	RM0130P37.....	108	RM0500U85.....	109
RM0018N25E.....	110	RM0130P37E.....	110	RM0500U85E.....	111
RM0018P80.....	108	RM0160P15.....	108	RM0500U96.....	109
RM0018P80E.....	110	RM0160P15E.....	110	RM0500U96E.....	111
RM0025N12.....	108	RM0160P23.....	108	RM0600U20.....	109
RM0025N12E.....	110	RM0160P23E.....	110	RM0600U20E.....	111
RM0025N20.....	108	RM0160P32.....	108	RM0600U40.....	109
RM0025N20E.....	110	RM0160P32E.....	110	RM0600U40E.....	111
RM0025P50.....	108	RM0160U75.....	108	RM0600U65.....	109
RM0025P50E.....	110	RM0160U75E.....	110	RM0600U65E.....	111
RM0035N12.....	108	RM0200P11.....	109	RM0600U80.....	109
RM0035N12E.....	110	RM0200P11E.....	111	RM0600U80E.....	111
RM0035N17.....	108	RM0200P19.....	109	RM0700U41.....	109
RM0035N17E.....	110	RM0200P19E.....	111	RM0700U41E.....	111
RM0035P40.....	108	RM0200P24.....	109	RM0700U68.....	109
RM0035P40E.....	110	RM0200P24E.....	111	RM0700U68E.....	111
RM0035P80.....	108	RM0200U55.....	109	RM0750U15.....	109
RM0035P80E.....	110	RM0200U55E.....	111	RM0750U15E.....	111
RM0045N12.....	108	RM0250P15.....	109	RM0750U25.....	109
RM0045N12E.....	110	RM0250P15E.....	111	RM0750U25E.....	111
RM0045P30.....	108	RM0250P19.....	109	RM0750U36.....	109
RM0045P30E.....	110	RM0250P19E.....	111	RM0750U36E.....	111
RM0045P70.....	108	RM0250U45.....	109	RM0750U60.....	109
RM0045P70E.....	110	RM0250U45E.....	111	RM0750U60E.....	111
RM0055P25.....	108	RM0250U90.....	109	RM0900U13.....	109
RM0055P25E.....	110	RM0250U90E.....	111	RM0900U13E.....	111
RM0055P50.....	108	RM0320P13.....	109	RM0900U26.....	109
RM0055P50E.....	110	RM0320P13E.....	111	RM0900U26E.....	111

GENERAL INFORMATION



GENERAL INFORMATION

ALPHA NUMERIC PART NUMBER INDEX

Catalog Part No.	Catalog Page No.	Catalog Part No.	Catalog Page No.	Catalog Part No.	Catalog Page No.
RM0900U32.....	109	S1EM030BB00.....	219	S1EM075BK00.....	219
RM0900U32E.....	111	S1EM030BB00S.....	215	S1EM075BK00S.....	215
RM0900U43.....	109	S1EM030BB30.....	221	S1EM075BK30.....	221
RM0900U43E.....	111	S1EM030BB30S.....	217	S1EM075BK30S.....	217
RM0900U53.....	109	S1EM030BK00.....	219	S1EM075KB00.....	219
RM0900U53E.....	111	S1EM030BK00S.....	215	S1EM075KB00S.....	215
RM1000U11.....	109	S1EM030BK30.....	221	S1EM075KB30.....	221
RM1000U11E.....	111	S1EM030BK30S.....	217	S1EM075KB30S.....	217
RM1000U18.....	109	S1EM030KB00.....	219	S1EM075KK00.....	220
RM1000U18E.....	111	S1EM030KB00S.....	215	S1EM075KK00S.....	216
RM1000U29.....	109	S1EM030KB30.....	221	S1EM075KK30.....	222
RM1000U29E.....	111	S1EM030KB30S.....	217	S1EM075KK30S.....	218
RM1000U38.....	109	S1EM030KK00.....	220	S1EM075PB00.....	220
RM1000U38E.....	111	S1EM030KK00S.....	216	S1EM075PB00S.....	216
RM1000U48.....	109	S1EM030KK30.....	222	S1EM075PB30.....	222
RM1000U48E.....	111	S1EM030KK30S.....	218	S1EM075PB30S.....	218
RM1200U10.....	109	S1EM030PB00.....	220	S1EM075PK00.....	220
RM1200U10E.....	111	S1EM030PB00S.....	216	S1EM075PK00S.....	216
RM1200U15.....	109	S1EM030PB30.....	222	S1EM075PK30.....	222
RM1200U15E.....	111	S1EM030PB30S.....	218	S1EM075PK30S.....	218
RM1200U18.....	109	S1EM030PK00.....	220	S1EM112BB00.....	219
RM1200U18E.....	111	S1EM030PK00S.....	216	S1EM112BB00S.....	215
RM1200U24.....	109	S1EM030PK30.....	222	S1EM112BB30.....	221
RM1200U24E.....	111	S1EM030PK30S.....	218	S1EM112BB30S.....	217
RM1200U30.....	109	S1EM045BB00.....	219	S1EM112BK00.....	219
RM1200U30E.....	111	S1EM045BB00S.....	215	S1EM112BK00S.....	215
RM1200U40.....	109	S1EM045BB30.....	221	S1EM112BK30.....	221
RM1200U40E.....	111	S1EM045BB30S.....	217	S1EM112BK30S.....	217
S1EM015BB00.....	219	S1EM045BK00.....	219	S1EM112KB00.....	219
S1EM015BB00S.....	215	S1EM045BK00S.....	215	S1EM112KB00S.....	215
S1EM015BB30.....	221	S1EM045BK30.....	221	S1EM112KB30.....	221
S1EM015BB30S.....	217	S1EM045BK30S.....	217	S1EM112KB30S.....	217
S1EM015BK00.....	219	S1EM045KB00.....	219	S1EM112KK00.....	220
S1EM015BK00S.....	215	S1EM045KB00S.....	215	S1EM112KK00S.....	216
S1EM015BK30.....	221	S1EM045KB30.....	221	S1EM112KK30.....	222
S1EM015BK30S.....	217	S1EM045KB30S.....	217	S1EM112KK30S.....	218
S1EM015KB00.....	219	S1EM045KK00.....	220	S1EM112PB00.....	220
S1EM015KB00S.....	215	S1EM045KK00S.....	216	S1EM112PB00S.....	216
S1EM015KB30.....	221	S1EM045KK30.....	222	S1EM112PB30.....	222
S1EM015KB30S.....	217	S1EM045KK30S.....	218	S1EM112PB30S.....	218
S1EM015KK00.....	220	S1EM045PB00.....	220	S1EM112PK00.....	220
S1EM015KK00S.....	216	S1EM045PB00S.....	216	S1EM112PK00S.....	216
S1EM015KK30.....	222	S1EM045PB30.....	222	S1EM112PK30.....	222
S1EM015KK30S.....	218	S1EM045PB30S.....	218	S1EM112PK30S.....	218
S1EM015PB00.....	220	S1EM045PK00.....	220	S1EM150BB00.....	219
S1EM015PB00S.....	216	S1EM045PK00S.....	216	S1EM150BB00S.....	215
S1EM015PB30.....	222	S1EM045PK30.....	222	S1EM150BB30.....	221
S1EM015PB30S.....	218	S1EM045PK30S.....	218	S1EM150BB30S.....	217
S1EM015PK00.....	220	S1EM075BB00.....	219	S1EM150BK00.....	219
S1EM015PK00S.....	216	S1EM075BB00S.....	215	S1EM150BK00S.....	215
S1EM015PK30.....	222	S1EM075BB30.....	221	S1EM150BK30.....	221
S1EM015PK30S.....	218	S1EM075BB30S.....	217	S1EM150BK30S.....	217

GENERAL
INFORMATION



GENERAL INFORMATION

ALPHA NUMERIC PART NUMBER INDEX

Catalog Part No.	Catalog Page No.	Catalog Part No.	Catalog Page No.	Catalog Part No.	Catalog Page No.
S1EM150KB00	219	S1EM300KK00	220	S1EM750PB00	220
S1EM150KB00S	215	S1EM300KK00S	216	S1EM750PB00S	216
S1EM150KB30	221	S1EM300KK30	222	S1EM750PB30	222
S1EM150KB30S	217	S1EM300KK30S	218	S1EM750PB30S	218
S1EM150KK00	220	S1EM300PB00	220	S1EM750PK00	220
S1EM150KK00S	216	S1EM300PB00S	216	S1EM750PK00S	216
S1EM150KK30	222	S1EM300PB30	222	S1EM750PK30	222
S1EM150KK30S	218	S1EM300PB30S	218	S1EM750PK30S	218
S1EM150PB00	220	S1EM300PK00	220	SMF015BE	176
S1EM150PB00S	216	S1EM300PK00S	216	SMF015BEC	178
S1EM150PB30	222	S1EM300PK30	222	SMF015FE	176
S1EM150PB30S	218	S1EM300PK30S	218	SMF015FEC	178
S1EM150PK00	220	S1EM500BB00	219	SMF015HE	177
S1EM150PK00S	216	S1EM500BB00S	215	SMF015HEC	179
S1EM150PK30	222	S1EM500BB30	221	SMF015LE	176
S1EM150PK30S	218	S1EM500BB30S	217	SMF015LEC	178
S1EM225BB00	219	S1EM500BK00	219	SMF015PE	177
S1EM225BB00S	215	S1EM500BK00S	215	SMF015PEC	179
S1EM225BB30	221	S1EM500BK30	221	SMF015XE	177
S1EM225BB30S	217	S1EM500BK30S	217	SMF015XEC	179
S1EM225BK00	219	S1EM500KB00	219	SMF025BE	176
S1EM225BK00S	215	S1EM500KB00S	215	SMF025BEC	178
S1EM225BK30	221	S1EM500KB30	221	SMF025FE	176
S1EM225BK30S	217	S1EM500KB30S	217	SMF025FEC	178
S1EM225KB00	219	S1EM500KK00	220	SMF025HE	177
S1EM225KB00S	215	S1EM500KK00S	216	SMF025HEC	179
S1EM225KB30	221	S1EM500KK30	222	SMF025LE	176
S1EM225KB30S	217	S1EM500KK30S	218	SMF025LEC	178
S1EM225KK00	220	S1EM500PB00	220	SMF025PE	177
S1EM225KK00S	216	S1EM500PB00S	216	SMF025PEC	179
S1EM225KK30	222	S1EM500PB30	222	SMF025XE	177
S1EM225KK30S	218	S1EM500PB30S	218	SMF025XEC	179
S1EM225PB00	220	S1EM500PK00	220	SMF037BE	176
S1EM225PB00S	216	S1EM500PK00S	216	SMF037BEC	178
S1EM225PB30	222	S1EM500PK30	222	SMF037FE	176
S1EM225PB30S	218	S1EM500PK30S	218	SMF037FEC	178
S1EM225PK00	220	S1EM750BB00	219	SMF037HE	177
S1EM225PK00S	216	S1EM750BB00S	215	SMF037HEC	179
S1EM225PK30	222	S1EM750BB30	221	SMF037LE	176
S1EM225PK30S	218	S1EM750BB30S	217	SMF037LEC	178
S1EM300BB00	219	S1EM750BK00	219	SMF037PE	177
S1EM300BB00S	215	S1EM750BK00S	215	SMF037PEC	179
S1EM300BB30	221	S1EM750BK30	221	SMF037XE	177
S1EM300BB30S	217	S1EM750BK30S	217	SMF037XEC	179
S1EM300BK00	219	S1EM750KB00	219	SMF050BE	176
S1EM300BK00S	215	S1EM750KB00S	215	SMF050BEC	178
S1EM300BK30	221	S1EM750KB30	221	SMF050FE	176
S1EM300BK30S	217	S1EM750KB30S	217	SMF050FEC	178
S1EM300KB00	219	S1EM750KK00	220	SMF050HE	177
S1EM300KB00S	215	S1EM750KK00S	216	SMF050HEC	179
S1EM300KB30	221	S1EM750KK30	222	SMF050LE	176
S1EM300KB30S	217	S1EM750KK30S	218	SMF050LEC	178

GENERAL INFORMATION

ALPHA NUMERIC PART NUMBER INDEX

Catalog Part No.	Catalog Page No.	Catalog Part No.	Catalog Page No.	Catalog Part No.	Catalog Page No.
SMF050PE.....	177	SMK015BB	181	SMK045KK	183
SMF050PEC.....	179	SMK015BBCN	185	SMK045KKC.....	187
SMF050XE.....	177	SMK015BK	181	SMK045PB	183
SMF050XEC.....	179	SMK015BKCN	185	SMK045PBC.....	187
SMF075BE.....	176	SMK015DB	181	SMK045PD	183
SMF075BEC.....	178	SMK015DBCN	185	SMK045PDC.....	187
SMF075FE.....	176	SMK015DK	182	SMK045PK	184
SMF075FEC.....	178	SMK015DKCN	186	SMK045PKC.....	188
SMF075HE.....	177	SMK015KB	182	SMK075BB	181
SMF075HEC.....	179	SMK015KBCN	186	SMK075BBC.....	185
SMF075LE.....	176	SMK015KD	182	SMK075BK	181
SMF075LEC.....	178	SMK015KDCN	186	SMK075BKC.....	185
SMF075PE.....	177	SMK015KK	183	SMK075DB	181
SMF075PEC.....	179	SMK015KKCN	187	SMK075DBC.....	185
SMF075XE.....	177	SMK015PB	183	SMK075DK	182
SMF075XEC.....	179	SMK015PBCN	187	SMK075DKC.....	186
SMF100BE.....	176	SMK015PD	183	SMK075KB	182
SMF100BEC.....	178	SMK015PDCN	187	SMK075KBC.....	186
SMF100FE.....	176	SMK015PK	184	SMK075KD	182
SMF100FEC.....	178	SMK015PKCN	188	SMK075KDC.....	186
SMF100HE.....	177	SMK030BB	181	SMK075KK	183
SMF100HEC.....	179	SMK030BBC.....	185	SMK075KKC.....	187
SMF100LE.....	176	SMK030BK	181	SMK075PB	183
SMF100LEC.....	178	SMK030BKC.....	185	SMK075PBC.....	187
SMF100PE.....	177	SMK030DB	181	SMK075PD	183
SMF100PEC.....	179	SMK030DBC.....	185	SMK075PDC.....	187
SMF100XE.....	177	SMK030DK	182	SMK075PK	184
SMF100XEC.....	179	SMK030DKC.....	186	SMK075PKC.....	188
SMF150BE.....	176	SMK030KB	182	SMK112BB.....	181
SMF150BEC.....	178	SMK030KBCN	186	SMK112BBC.....	185
SMF150FE.....	176	SMK030KD	182	SMK112BK.....	181
SMF150FEC.....	178	SMK030KDCN	186	SMK112BKC.....	185
SMF150HE.....	177	SMK030KK	183	SMK112DB	181
SMF150HEC.....	179	SMK030KKCN	187	SMK112DBC.....	185
SMF150LE.....	176	SMK030PB	183	SMK112DK	182
SMF150LEC.....	178	SMK030PBCN	187	SMK112DKC.....	186
SMF150PE.....	177	SMK030PD	183	SMK112KB.....	182
SMF150PEC.....	179	SMK030PDC.....	187	SMK112KBC.....	186
SMF150XE.....	177	SMK030PK	184	SMK112KD	182
SMF150XEC.....	179	SMK030PKCN	188	SMK112KDC.....	186
SMF167BE.....	176	SMK045BB	181	SMK112KK.....	183
SMF167BEC.....	178	SMK045BBC.....	185	SMK112KKC.....	187
SMF167FE.....	176	SMK045BK	181	SMK112PB.....	183
SMF167FEC.....	178	SMK045BKC.....	185	SMK112PBC.....	187
SMF167HE.....	177	SMK045DB	181	SMK112PD	183
SMF167HEC.....	179	SMK045DBC.....	185	SMK112PDC.....	187
SMF167LE.....	176	SMK045DK	182	SMK112PK.....	184
SMF167LEC.....	178	SMK045DKC.....	186	SMK112PKC.....	188
SMF167PE.....	177	SMK045KB	182	SMK150BB	181
SMF167PEC.....	179	SMK045KBC.....	186	SMK150BBC.....	185
SMF167XE.....	177	SMK045KD	182	SMK150BK	181
SMF167XEC.....	179	SMK045KDC.....	186	SMK150BKC.....	185

GENERAL INFORMATION



GENERAL INFORMATION

ALPHA NUMERIC PART NUMBER INDEX

Catalog Part No.	Catalog Page No.	Catalog Part No.	Catalog Page No.	Catalog Part No.	Catalog Page No.
SMK150DB	181	SMK300PD	183	SMT13K015PBKN	201
SMK150DBC	185	SMK300PDC	187	SMT13K015PBS	199
SMK150DK	182	SMK300PK	184	SMT13K015PKKN	201
SMK150DKC	186	SMK300PKC	188	SMT13K015PKS	199
SMK150KB	182	SMK500BB	181	SMT13K030BBKN	200
SMK150KBC	186	SMK500BBC	185	SMT13K030BBS	198
SMK150KD	182	SMK500BK	181	SMT13K030BKKN	200
SMK150KDC	186	SMK500BKC	185	SMT13K030BKS	198
SMK150KK	183	SMK500DB	181	SMT13K030KBKN	200
SMK150KKC	187	SMK500DBC	185	SMT13K030KBS	198
SMK150PB	183	SMK500DK	182	SMT13K030KKN	201
SMK150PBC	187	SMK500DKC	186	SMT13K030KKS	199
SMK150PD	183	SMK500KB	182	SMT13K030PBKN	201
SMK150PDC	187	SMK500KBC	186	SMT13K030PBS	199
SMK150PK	184	SMK500KD	182	SMT13K030PKKN	201
SMK150PKC	188	SMK500KDC	186	SMT13K030PKS	199
SMK225BB	181	SMK500KK	183	SMT13K045BBK	200
SMK225BBC	185	SMK500KKC	187	SMT13K045BBS	198
SMK225BK	181	SMK500PB	183	SMT13K045BKK	200
SMK225BKC	185	SMK500PBC	187	SMT13K045BKS	198
SMK225DB	181	SMK500PD	183	SMT13K045KBK	200
SMK225DBC	185	SMK500PDC	187	SMT13K045KBS	198
SMK225DK	182	SMK500PK	184	SMT13K045KKK	201
SMK225DKC	186	SMK500PKC	188	SMT13K045KKS	199
SMK225KB	182	SMK750BB	181	SMT13K045PBK	201
SMK225KBC	186	SMK750BBC	185	SMT13K045PBS	199
SMK225KD	182	SMK750BK	181	SMT13K045PKK	201
SMK225KDC	186	SMK750BKC	185	SMT13K045PKS	199
SMK225KK	183	SMK750DB	181	SMT13K075BBK	200
SMK225KKC	187	SMK750DBC	185	SMT13K075BBS	198
SMK225PB	183	SMK750DK	182	SMT13K075BKK	200
SMK225PBC	187	SMK750DKC	186	SMT13K075BKS	198
SMK225PD	183	SMK750KB	182	SMT13K075KBK	200
SMK225PDC	187	SMK750KBC	186	SMT13K075KBS	198
SMK225PK	184	SMK750KD	182	SMT13K075KKK	201
SMK225PKC	188	SMK750KDC	186	SMT13K075KKS	199
SMK300BB	181	SMK750KK	183	SMT13K075PBK	201
SMK300BBC	185	SMK750KKC	187	SMT13K075PBS	199
SMK300BK	181	SMK750PB	183	SMT13K075PKK	201
SMK300BKC	185	SMK750PBC	187	SMT13K075PKS	199
SMK300DB	181	SMK750PD	183	SMT13K112BBK	200
SMK300DBC	185	SMK750PDC	187	SMT13K112BBS	198
SMK300DK	182	SMK750PK	184	SMT13K112BKK	200
SMK300DKC	186	SMK750PKC	188	SMT13K112BKS	198
SMK300KB	182	SMT13K015BBKN	200	SMT13K112KBK	200
SMK300KBC	186	SMT13K015BBS	198	SMT13K112KBS	198
SMK300KD	182	SMT13K015BKKN	200	SMT13K112KKK	201
SMK300KDC	186	SMT13K015BKS	198	SMT13K112KKS	199
SMK300KK	183	SMT13K015KBKN	200	SMT13K112PBK	201
SMK300KKC	187	SMT13K015KBS	198	SMT13K112PBS	199
SMK300PB	183	SMT13K015KKKN	201	SMT13K112PKK	201
SMK300PBC	187	SMT13K015KKS	199	SMT13K112PKS	199

GENERAL INFORMATION

ALPHA NUMERIC PART NUMBER INDEX

Catalog Part No.	Catalog Page No.	Catalog Part No.	Catalog Page No.	Catalog Part No.	Catalog Page No.
SMT13K150BBK.....	200	SMT13K750KBK.....	200	SP350ACP.....	48
SMT13K150BBS.....	198	SMT13K750KBS.....	198	SP350AR.....	48
SMT13K150BKK.....	200	SMT13K750KKK.....	201	SP350KHP.....	50
SMT13K150BKS.....	198	SMT13K750KKS.....	199	SP350KHR.....	50
SMT13K150KBK.....	200	SMT13K750PBK.....	201	SP350MQMJ.....	49
SMT13K150KBS.....	198	SMT13K750PBS.....	199	SP350NJ.....	51
SMT13K150KKK.....	201	SMT13K750PKK.....	201	SP350PR.....	51
SMT13K150KKS.....	199	SMT13K750PKS.....	199	SP350QR.....	49
SMT13K150PBK.....	201	SP1000ACP.....	48	SP350SP.....	52
SMT13K150PBS.....	199	SP1000KHP.....	50	SP350SR.....	52
SMT13K150PKK.....	201	SP1000MQMJ.....	49	SP5000ACP.....	48
SMT13K150PKS.....	199	SP1000NJ.....	51	SP5000MQMJ.....	49
SMT13K225BBK.....	200	SP1000SP.....	52	SP500ACP.....	48
SMT13K225BBS.....	198	SP100ACP.....	48	SP500AR.....	48
SMT13K225BKK.....	200	SP100AR.....	48	SP500KHP.....	50
SMT13K225BKS.....	198	SP100KHP.....	50	SP500KHR.....	50
SMT13K225KBK.....	200	SP100KHR.....	50	SP500MQMJ.....	49
SMT13K225KBS.....	198	SP100MQMJ.....	49	SP500NJ.....	51
SMT13K225KKK.....	201	SP100NJ.....	51	SP500PR.....	51
SMT13K225KKS.....	199	SP100PR.....	51	SP500QR.....	49
SMT13K225PBK.....	201	SP100QR.....	49	SP500SP.....	52
SMT13K225PBS.....	199	SP100SP.....	52	SP500SR.....	52
SMT13K225PKK.....	201	SP100SR.....	52	SP50ACP.....	48
SMT13K225PKS.....	199	SP1500ACP.....	48	SP50AR.....	48
SMT13K300BBK.....	200	SP1500KHP.....	50	SP50KHP.....	50
SMT13K300BBS.....	198	SP1500MQMJ.....	49	SP50KHR.....	50
SMT13K300BKK.....	200	SP1500NJ.....	51	SP50MQMJ.....	49
SMT13K300BKS.....	198	SP1500SP.....	52	SP50NJ.....	51
SMT13K300KBK.....	200	SP150ACP.....	48	SP50PR.....	51
SMT13K300KBS.....	198	SP150AR.....	48	SP50QR.....	49
SMT13K300KKK.....	201	SP150KHP.....	50	SP50SP.....	52
SMT13K300KKS.....	199	SP150KHR.....	50	SP50SR.....	52
SMT13K300PBK.....	201	SP150MQMJ.....	49	SP750ACP.....	48
SMT13K300PBS.....	199	SP150NJ.....	51	SP750KHP.....	50
SMT13K300PKK.....	201	SP150PR.....	51	SP750MQMJ.....	49
SMT13K300PKS.....	199	SP150QR.....	49	SP750NJ.....	51
SMT13K500BBK.....	200	SP150SP.....	52	SP750SP.....	52
SMT13K500BBS.....	198	SP150SR.....	52	SPFBK1.....	53
SMT13K500BKK.....	200	SP2000ACP.....	48	SPFG1.....	53
SMT13K500BKS.....	198	SP2000MQMJ.....	49	Y003CECB.....	247
SMT13K500KBK.....	200	SP250ACP.....	48	Y003PKCB.....	247
SMT13K500KBS.....	198	SP250AR.....	48	Y003QTCB.....	247
SMT13K500KKK.....	201	SP250KHP.....	50	Y006CECB.....	247
SMT13K500KKS.....	199	SP250KHR.....	50	Y006PKCB.....	247
SMT13K500PBK.....	201	SP250MQMJ.....	49	Y006QTCB.....	247
SMT13K500PBS.....	199	SP250NJ.....	51	Y009CECB.....	247
SMT13K500PKK.....	201	SP250PR.....	51	Y009PKCB.....	247
SMT13K500PKS.....	199	SP250QR.....	49	Y009QTCF.....	247
SMT13K750BBK.....	200	SP250SP.....	52	Y015CECB.....	247
SMT13K750BBS.....	198	SP250SR.....	52	Y015PKCB.....	247
SMT13K750BKK.....	200	SP3000ACP.....	48	Y015QTCF.....	247
SMT13K750BKS.....	198	SP3000MQMJ.....	49	Y030CECF.....	247

GENERAL INFORMATION



GENERAL INFORMATION

ALPHA NUMERIC PART NUMBER INDEX

Catalog Part No.	Catalog Page No.	Catalog Part No.	Catalog Page No.	Catalog Part No.	Catalog Page No.
Y030PKCF	247				
Y030QTCN	247				
Y045CECF	247				
Y045PKCN.....	247				
Y045QTC	247				
Y075CECN	247				
Y075PKCN.....	247				
Y075QTC	247				
Y112PKC	247				
Y112QTC	247				
Y150PKC	247				
Y150QTC.....	247				
Y225PKC	247				
Y225QTC.....	247				
Y300PKC	247				
Y500PKC	247				

Page Intentionally Left Blank

GENERAL
INFORMATION



GENERAL INFORMATION

ALPHA NUMERIC PART NUMBER INDEX

Catalog Part No.	Catalog Page No.	Catalog Part No.	Catalog Page No.	Catalog Part No.	Catalog Page No.
Page Intentionally Left Blank					

GENERAL
INFORMATION



GENERAL INFORMATION

ALPHA NUMERIC PART NUMBER INDEX

Catalog Part No.	Catalog Page No.	Catalog Part No.	Catalog Page No.	Catalog Part No.	Catalog Page No.
Page Intentionally Left Blank					

GENERAL INFORMATION



GENERAL INFORMATION

ALPHA NUMERIC PART NUMBER INDEX

Catalog Part No.	Catalog Page No.	Catalog Part No.	Catalog Page No.	Catalog Part No.	Catalog Page No.
Page Intentionally Left Blank					

GENERAL
INFORMATION



GENERAL INFORMATION

Yes, I am interested in receiving the following information on other HPS Products.

Literature Name	Code	Qty
Showcase of Products Brochure	SCOPB	_____
Transformer Products Catalog	HTP-10	_____
Medium Voltage Dry-Type Distribution (Power) Transformers	HPWR-10	_____
Capabilities Brochure	HPSCB8	_____
Energy Efficient Distribution Transformer Brochure	ENEDIS	_____
HPS Spartan® Industrial Open Core & Coil Control Transformer Brochure	SPACON	_____
HPS Imperator® Encapsulated Machine Tool Industrial Control Transformers	ENCCON	_____
HPS Fortress™ Commercial Encapsulated Brochure	FORPOT	_____
HPS Titan® Series Encapsulated Distribution Transformer Brochure	TSETB8	_____
HPS PowerPlus™ Mini Power Center Brochure	PWRPLS11	_____
Installation, Operation & Maintenance Guide - For Dry-Type Transformer Which utilize a NH Series, NJ1, NJ2, NJ3 Or NJ4 Enclosure	IOMGDDI	_____
Installation, Operation & Maintenance Guide - For Single Phase Encapsulated Transformers Up To 50 kVA	IOMGE1PH	_____
Installation, Operation & Maintenance Guide - For Three Phase Encapsulated Transformers Up To 150 kVA	IOMGE3PH	_____
Installation, Operation & Maintenance Guide - For Dry-Type Transformer Which Utilize A NJ6, NJ7 or P Series Enclosure	IOMGPOW	_____

The literature listed above is available either electronically as a free PDF download or paper copies. To access the free PDF versions, please go to "http://www.hammondpowersolutions.com/products/product_literature/index.php". To receive paper copies of any of the catalogs, brochures or flyers shown above, please fill in the information below, photocopy this page and fax it to the following:

FAX TO: Literature Services
 Hammond Power Solutions Inc.
 Canada: (519) 822-9688
 U.S.: (608) 356-2080

E-MAIL: catalog@hammondpowersolutions.com
Web: www.hammondpowersolutions.com

My need for Transformer Products is Immediate Future

Please send me the name of your local HPS Sales Representative

Please provide me with the name of the local Authorized HPS Distributor

Name: _____

E-Mail Address: _____

Company: _____

Address: _____

City, State: _____

Zip Code: _____

Telephone: _____

Fax: _____

Please check one:

- | | |
|---|---|
| <input type="checkbox"/> Electrical Distributor | <input type="checkbox"/> Electronic Distributor |
| <input type="checkbox"/> Contractor | <input type="checkbox"/> Panel Builder |
| <input type="checkbox"/> MRO | <input type="checkbox"/> OEM |
| <input type="checkbox"/> Consultant | <input type="checkbox"/> Engineering Firm |
| <input type="checkbox"/> Other: _____ | |

GENERAL INFORMATION

